

### SINGLE PACKAGE ROOFTOP UNITS WITH X-VANE™ FAN TECHNOLOGY: GAS HEATING/ELECTRIC COOLING (RGV) AND ELECTRIC COOLING/OPTIONAL ELECTRIC HEAT (RAV) 3 – 6 TON

The new 3 to 6 Ton RGV/RAV series rooftop units (RTU) with X-Vane™ Fan Technology provides value added benefits never seen in this type of equipment before. New major design features include:

- Patent pending, the industry's first beltless direct-drive vane axial fan for rooftop units with electric commutated variable speed motor.
- Reliable fixed speed scroll compressor on 3-5 ton sizes and 2 stage scroll technology on 6 ton sizes.
- Upgraded unit control board with intuitive indoor fan adjustment.
- Reliable copper tube / aluminum fin condenser coil with  $\frac{5}{16}$ -in. tubing to help reduce refrigerant charge versus prior designs.
- New outdoor fan system with rugged, lightweight high impact composite fan blade.



RGV/RAV036-072

X-Vane™ Fan

#### Installation ease

All RGV/RAV units are field convertible to horizontal air flow, which makes it easy to adjust to unexpected job site complications. RGV/RAV rooftop units up to 6 tons are specifically designed to fit on our existing roof curbs dating back to 1989 for worry-free original fit. Also, our large control box gives you room to work and room to mount accessory controls. Intuitive controls make setting up the required fan speed simple and accurate. Access to the blower section is no longer needed with the new design.

#### Easy to maintain

With the new Vane Axial fan and direct drive ECM motor, there is no longer a need to adjust belts or pulleys as in past designs. This frees up maintenance and installation time.

Easy access handles provide quick and easy access to all normally serviced components. Our “no-strip” screw system has superior holding power and guides screws into position while preventing the screw from stripping the unit's metal.

Sloped, corrosion resistant composite drain pan sheds water and won't rust.

RGV units are designed with a naturally draining heat exchanger. Unlike positive pressure heat exchangers, this does not need to be periodically, manually drained. This saves labor and maintenance expense.

#### Easy to use

The newly re-designed Unit Control Board puts all connections and troubleshooting points in one convenient place. Most low voltage connections are made to the same board for easy access. Setting up the fan is made simple by an intuitive switch and rotary dial arrangement. RGV/RAV rooftops have high and low pressure switches, a filter drier, and 2-in. filters standard.

#### X-Vane Fan Technology

Direct drive X-Vane Fan Technology indoor fan system uses vane axial fan design and electrically commutated motors. This new Vane Axial design over past belt drive systems has 75% fewer moving parts, uses up to 40% less energy and has no fan belts, blower bearings, or shaft.

#### Design features include:

- Single-stage units deliver SEERs up to 14.0 and EERs up to 11.8. Two-stage units deliver IEERs up to 15.2 and EERs up to 11.2.
- All models are capable of either vertical or horizontal airflow.
- RGV/RAV rooftop units (RTU) were designed by customers for customers. With “no-strip” screw collars, handled access panels, and more the unit is easy to install, easy to maintain, and easy to use. Your new 3 to 6 ton RGV/RAV rooftop unit (RTU) provides optimum comfort and control from a packaged rooftop.

# Table of contents

	PAGE		PAGE
FEATURES/BENEFITS .....	2	PERFORMANCE DATA .....	26
MODEL NUMBER NOMENCLATURE .....	4	FAN DATA .....	39
CAPACITY RATINGS .....	6	ELECTRICAL DATA .....	96
PHYSICAL DATA .....	9	TYPICAL WIRING DIAGRAMS .....	118
OPTIONS AND ACCESSORIES .....	14	SEQUENCE OF OPERATION .....	130
BASE UNIT DIMENSIONS .....	19	APPLICATION DATA .....	133
ACCESSORY DIMENSIONS .....	25	GUIDE SPECIFICATIONS .....	135

## Features/Benefits

### Value-added features include:

- Optional Hot Gas Re-Heat dehumidification system for improved part load humidity performance
- R-410A refrigerant
- Single point gas and electrical connections
- 3 to 5 ton models use fixed refrigerant metering devices and 6 ton models use a TXV
- Scroll compressors with internal line-break overload protection

### Operating efficiency and flexibility

The RGV/RAV rooftops exceed ASHRAE (American Society of Heating, Refrigerating, and Air-Conditioning Engineers) 90.1-2016, IECC<sup>1</sup> (International Energy Conservation Code) IECC-2018 minimum efficiency requirements.

### Field convertible airflow

All RGV/RAV 3 to 6 ton units are field-convertible to horizontal airflow, which makes it easy to adjust to unexpected job site complications.

### Comfort control

Our patented Hot Gas Re-Heat dehumidification system is an all-inclusive factory-installed option on gas heating/electric cooling and electric cooling/electric heat models. This system provides reliable, flexible operation to meet indoor part load sensible and latent requirements.

---

<sup>1</sup> IECC is a registered trademark of the International Code Council, Inc.

**UNIT PERFORMANCE DATA — Single Stage Cooling /Single Circuit**

UNIT	Nom. Tons	COOLING				GAS HEATING		Unit Dimensions H x W x L	Shipping Weight lb. [kg]
		Net. Cap (Btuh)	EER	SEER	IEER w/ 2-Speed Indoor Fan Motor	Input Cap. (Btuh) Stage 2	Thermal Efficiency (%)		
RGV036* <sup>^</sup> DA0AAA	3	34,400	11.5	14.0	N/A	65,000 - 90,000	80 - 82	33 3/8" x 46 5/8" x 74 3/8"	522 [237]
RGV048* <sup>^</sup> DA0AAA	4	47,000	11.6	14.0	N/A	65,000 - 130,000	80 - 82	33 3/8" x 46 5/8" x 74 3/8"	583 [265]
RGV060* <sup>^</sup> DA0AAA	5	58,500	11.0	14.0	N/A	65,000 - 130,000	80 - 82	33 3/8" x 46 5/8" x 74 3/8"	596 [271]

**UNIT PERFORMANCE DATA — Two Stage Cooling /Single Circuit**

UNIT	Nom. Tons	COOLING				GAS HEATING		Unit Dimensions H x W x L	Shipping Weight lb. [kg]
		Net. Cap (Btuh)	EER	SEER	IEER w/ 2-Speed Indoor Fan Motor	Input Cap. (Btuh) Stage 2	Thermal Efficiency (%)		
RGV072* <sup>^</sup> DA0AAA	6	70,000	11.0	N/A	15.0	67,000 - 150,000	80 - 81	41 3/8" x 46 5/8" x 74 3/8"	647 [294]

**UNIT PERFORMANCE DATA — Single Stage Cooling /Single Circuit**

UNIT	Nom. Tons	COOLING					Unit Dimensions H x W x L	Shipping Weight lb. [kg]
		Net. Cap (Btuh)	EER	SEER	Total Power (kW)	IEER w/ 2-Speed Indoor Fan Motor		
RAV036*0DA0AAA	3	34,400	11.7	14.0	2.9	N/A	33 3/8" x 46 5/8" x 74 3/8"	477 [217]
RAV048*0DA0AAA	4	47,000	11.8	14.0	4.0	N/A	33 3/8" x 46 5/8" x 74 3/8"	538 [244]
RAV060*0DA0AAA	5	58,500	11.2	14.0	5.2	N/A	33 3/8" x 46 5/8" x 74 3/8"	551 [250]

**UNIT PERFORMANCE DATA — Two Stage Cooling /Single Circuit**

UNIT	Nom. Tons	COOLING					Unit Dimensions H x W x L	Shipping Weight lb. [kg]
		Net. Cap (Btuh)	EER	SEER	Total Power (kW)	IEER w/ 2-Speed Indoor Fan Motor		
RAV072*0DA0AAA	6	70,000	11.2	N/A	5.7	15.2	41 3/8" x 46 5/8" x 74 3/8"	602 [273]

\* Indicates Unit voltage: K = 208/230-1-60, H = 208/230-3-60, L = 460-3-60, S = 575-3-60

<sup>^</sup> See model nomenclature listing for gas heating options.

**NOTE: BASE MODEL NUMBERS LISTED. SEE MODEL NOMENCLATURE LISTING FOR ADDITIONAL OPTIONS**

# Model number nomenclature

## RGV MODEL NUMBER NOMENCLATURE

MODEL SERIES	R	G	V	0	6	0	L	D	D	A	0	A	A	A
Position Number	1	2	3	4	5	6	7	8	9	10	11	12	13	14
R = Rooftop														
G = Gas Heat / Electric Cooling Type														
V = 14 SEER (036-060), 15 IEER (072) Standard Efficiency														
036 = 36,000 BTUH = 3 Tons 048 = 48,000 BTUH = 4 Tons 060 = 60,000 BTUH = 5 Tons 072 = 72,000 BTUH = 6 Tons Nominal Cooling Capacity														
K = 208/230-1-60 H = 208/230-3-60 L = 460-3-60 S = 575-3-60 Voltage														
D = Low Heat E = Medium Heat F = High Heat L = Low NOx, Low Heat S = Low Heat, Stainless Steel Heat Exchanger R = Medium Heat, Stainless Steel Heat Exchanger T = High Heat, Stainless Steel Heat Exchanger Heating Capacity <sup>1</sup>														
D = Direct Drive X-Vane™ Fan – Standard Static E = Direct Drive X-Vane Fan – High Static F = Direct Drive X-Vane Fan – Medium Static G = Direct Drive X-Vane Fan – High Static with Hot Gas Re-Heat <sup>2</sup> Motor Option (Indoor Fan)														
A = None B = Economizer with Barometric relief, OA Temp sensor E = Economizer with Barometric relief + CO <sub>2</sub> sensor, OA Temp sensor H = Economizer with Barometric relief, enthalpy sensor L = Economizer with Barometric relief + CO <sub>2</sub> sensor, enthalpy sensor P = 2-Position Damper (036-060 models only) U = Temp Ultra Low Leak Economizer with Barometric relief W = Enthalpy Ultra Low Leak Economizer with Barometric relief Outdoor Air Options / Control <sup>3</sup>														
0A = No Options 4B = Non Fused Disconnect Switch AA = Hinged Access Panels AT = Un-Powered Convenience Outlet BB = Powered Convenience Outlet BP = Return Air Smoke Detector BR = Supply Air Smoke Detector CJ = Condensate Overflow Switch Factory Installed Options <sup>4</sup>														
A = Aluminum / Copper Cond & Evap Coil B = Precoat Alum/Copper Cond with Alum / Copper Evap (3 phase only) C = E-Coated Alum/Copper Cond with Alum / Copper Evap (3 phase only) D = E-Coated Alum / Copper Cond & Evap (3 phase only) E = Copper/Copper Cond & Alum/Copper Evap (3 phase only) F = Copper/Copper Cond & Evap (3 phase only) Condenser / Evaporator Coil Configuration														
A = Economizer control (W7212) for EconoMiZer® IV (036-060 models) B = Economizer control (W7220) for EconoMiZer X (036-072 models) Economizer Control														

**NOTE:** Factory-installed options are NOT available on single phase models. This includes economizers and 2-position damper.

<sup>1</sup>See Specification Sheet for actual heating capacities.

<sup>2</sup>Hot Gas Re-Heat system includes Low Ambient controller.

<sup>3</sup>See Specification Sheet for details.

<sup>4</sup>Combinations of factory-installed options are available, see Specifications Sheet for details.

**RAV MODEL NUMBER NOMENCLATURE**

MODEL SERIES	R	A	V	0	6	0	L	0	D	A	0	A	A	A
Position Number	1	2	3	4	5	6	7	8	9	10	11	12	13	14
R = Rooftop														
A = Electric/Electric, Cooling Only Type														
V = 14 SEER (036-060) 15 IEER (072) Standard Efficiency														
036 = 36,000 BTUH = 3 Tons 048 = 48,000 BTUH = 4 Tons 060 = 60,000 BTUH = 5 Tons 072 = 72,000 BTUH = 6 Tons Nominal Cooling Capacity														
K = 208/230-1-60 H = 208/230-3-60 L = 460-3-60 S = 575-3-60 Voltage														
0 = No Heat Heating Capacity <sup>1</sup>														
D = Direct Drive X-Vane™ Fan – Standard Static E = Direct Drive X-Vane Fan – High Static F = Direct Drive X-Vane Fan – Medium Static G = Direct Drive X-Vane Fan – High Static with Hot Gas Re-Heat <sup>2</sup> Motor Option (Indoor Fan)														
A = None B = Economizer with Barometric relief, OA Temp sensor E = Economizer with Barometric relief + CO <sub>2</sub> sensor, OA Temp sensor H = Economizer with Barometric relief, enthalpy sensor L = Economizer with Barometric relief + CO <sub>2</sub> sensor, enthalpy sensor P = 2-Position Damper (036-060 models only) U = Temp Ultra Low Leak Economizer with Barometric relief W = Enthalpy Ultra Low Leak Economizer with Barometric relief Outdoor Air Options / Control <sup>3</sup>														
OA = No Options 4B = Non Fused Disconnect Switch AA = Hinged Access Panels AT = Un-Powered Convenience Outlet BB = Powered Convenience Outlet BP = Return Air Smoke Detector BR = Supply Air Smoke Detector CJ = Condensate Overflow Switch Factory Installed Options <sup>4</sup>														
A = Aluminum / Copper Cond and Evap Coil B = Precoat Alum/Copper Cond with Alum / Copper Evap (3 phase only) C = E-Coated Alum/Copper Cond with Alum / Copper Evap (3 phase only) D = E-Coated Alum / Copper Cond and Evap (3 phase only) E = Copper/Copper Cond and Alum/Copper Evap (3 phase only) F = Copper/Copper Cond and Evap (3 phase only) Condenser / Evaporator Coil Configuration														
A = Economizer control (W7212) for EconoMiZer® IV (036-060 models) B = Economizer control (W7220) for EconoMiZer X (036-072 models) Economizer Control														

NOTE: On single phase (K voltage code) models the following are not available as factory-installed options:

- Coated or copper fin coils
- Economizers and 2-position damper
- Powered convenience outlet

<sup>1</sup>See Specification Sheet for actual heating capacities.

<sup>2</sup>Hot Gas Re-Heat system includes Low Ambient controller.

<sup>3</sup>See Specification Sheet for details.

<sup>4</sup>Combinations of factory-installed options are available, see Specifications Sheet for details.

# Capacity ratings

## RGV AHRI RATINGS

RGV UNIT	COOLING STAGES	NOMINAL CAPACITY (TONS)	NET COOLING CAPACITY (MBH)	TOTAL POWER (kW)	SEER	EER	IEER WITH 2-SPEED INDOOR FAN MOTOR
RGV036	1	3	34.5	3.0	14.0	11.5	N/A
RGV048	1	4	47.0	4.1	14.0	11.6	N/A
RGV060	1	5	58.5	5.3	14.0	11.0	N/A
RGV072	2	6	70.0	6.4	N/A	11.0	15.0

### LEGEND

**AHRI** — Air-Conditioning, Heating and Refrigeration Institute  
**EER** — Energy Efficiency Ratio  
**IEER** — Integrated Energy Efficiency Ratio  
**SEER** — Integrated Energy Efficiency Ratio

### NOTES:

- Rated in accordance with AHRI Standards 210/240 (036-060 size) and 340/360 (072 size).
- Rating are based on:  
**Cooling Standard:** 80°F (27°C) db, 67°F (19°C) wb indoor air temperature and 95°F (35°C) db outdoor air temperature.  
**IEER Standard:** A measure that expresses cooling part-load EER efficiency for commercial unitary air-conditioning and heat pump equipment on the basis of weighted operation at various load capacities.
- All RGV units comply with ASHRAE 90.1-2016 (American Society of Heating, Refrigerating, and Air-Conditioning Engineers) and DOE-2018 (Department of Energy) Energy Standard for minimum SEER and EER requirements.
- RGV units comply with US Energy Policy Act (2005). To evaluate code compliance requirements, refer to state and local codes.

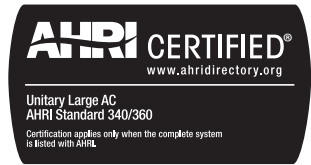

## RAV AHRI RATINGS

RAV UNIT	COOLING STAGES	NOMINAL CAPACITY (TONS)	NET COOLING CAPACITY (MBH)	TOTAL POWER (kW)	SEER	EER	IEER WITH 2-SPEED INDOOR FAN MOTOR
RAV036	1	3	34.4	2.9	14.0	11.7	N/A
RAV048	1	4	47.0	4.0	14.0	11.8	N/A
RAV060	1	5	58.5	5.2	14.0	11.2	N/A
RAV072	2	6	70.0	6.3	N/A	11.2	15.2

### LEGEND

**AHRI** — Air-Conditioning, Heating and Refrigeration Institute  
**EER** — Energy Efficiency Ratio  
**IEER** — Integrated Energy Efficiency Ratio  
**SEER** — Integrated Energy Efficiency Ratio

### NOTES:

- Rated in accordance with AHRI Standards 210/240 (036-060 size) and 340/360 (072 size).
- Rating are based on:  
**Cooling Standard:** 80°F (27°C) db, 67°F (19°C) wb indoor air temperature and 95°F (35°C) db outdoor air temperature.  
**IEER Standard:** A measure that expresses cooling part-load EER efficiency for commercial unitary air-conditioning and heat pump equipment on the basis of weighted operation at various load capacities.
- All RAV units comply with ASHRAE 90.1-2016 (American Society of Heating, Refrigerating, and Air-Conditioning Engineers) and DOE-2018 (Department of Energy) Energy Standard for minimum SEER and EER requirements.
- RAV units comply with US Energy Policy Act (2005). To evaluate code compliance requirements, refer to state and local codes.



**SOUND RATINGS TABLE**

RGV/RAV UNIT	COOLING STAGES	OUTDOOR SOUND (dB) AT 60 Hz								
		A-WEIGHTED	63	125	250	500	1000	2000	4000	8000
036	1	79	85.6	84.7	80.5	76.0	72.4	68.0	62.8	59.3
048	1	79	85.6	84.7	80.5	76.0	72.4	68.0	62.8	59.3
060	1	79	85.6	84.7	80.5	76.0	72.4	68.0	62.8	59.3
072	2	79	85.6	84.7	80.5	76.0	72.4	68.0	62.8	59.3

**LEGEND**

**dB** — Decibel

**NOTES:**

1. Outdoor sound data is measured in accordance with AHRI.
2. Measurements are expressed in terms of sound power. Do not compare these values to sound pressure values because sound

pressure depends on specific environmental factors which normally do not match individual applications. Sound power values are independent of the environment and therefore more accurate.

3. A-weighted sound ratings filter out very high and very low frequencies, to better approximate the response of "average" human ear. A-weighted measurements for ICP units are taken in accordance with AHRI.

**MINIMUM - MAXIMUM AIRFLOW RATINGS (CFM) — NATURAL GAS AND PROPANE**

UNIT	HEAT LEVEL	VOLTAGE	COOLING				HEATING*	
			MINIMUM AIRFLOW CFM	MINIMUM 2-SPEED AIRFLOW (LOW SPEED)	MINIMUM 2-SPEED AIRFLOW (HIGH SPEED)	MAXIMUM AIRFLOW CFM	MINIMUM AIRFLOW CFM	MAXIMUM AIRFLOW CFM
RGV036	LOW	1 PHASE	900	N/A	N/A	1500	890	1950
	MED						800	1520
	HIGH						N/A	N/A
RGV048	LOW	1 PHASE	1200	N/A	N/A	2000	890	2440
	MED						1050	2280
	HIGH						1220	2170
RGV060	LOW	1 PHASE	1500	N/A	N/A	2500	890	3250
	MED						1050	2730
	HIGH						1220	2790
RGV036	LOW	3 PHASE	900	N/A	N/A	1500	910	2010
	MED						960	1160
	HIGH						N/A	N/A
RGV048	LOW	3 PHASE	1200	N/A	N/A	2000	910	2010
	MED						1250	2330
	HIGH						1390	2220
RGV060	LOW	3 PHASE	1500	N/A	N/A	2500	910	2510
	MED						1250	2720
	HIGH						1390	2780
RGV072	LOW	3 PHASE	1800	1200	1800	3000	910	3350
	MED						1250	3260
	HIGH						1390	3170

\*Heating rating values are identical for aluminum heat exchangers and stainless steel heat exchangers.

**MINIMUM - MAXIMUM AIRFLOW RATINGS (CFM) — COOLING UNITS AND ACCESSORY ELECTRIC HEAT**

UNIT	COOLING				ELECTRIC HEAT*	
	MINIMUM AIRFLOW CFM	MINIMUM 2-SPEED AIRFLOW (LOW SPEED)	MINIMUM 2-SPEED AIRFLOW (HIGH SPEED)	MAXIMUM AIRFLOW CFM	MINIMUM AIRFLOW CFM	MAXIMUM AIRFLOW CFM
RAV036	900	N/A	N/A	1500	900	1500
RAV048	1200	N/A	N/A	2000	1200	2000
RAV060	1500	N/A	N/A	2500	1500	2500
RAV072	1800	1200	1800	3000	1800	3000

\*Electric heat modules are available as field-installed accessories for RAV units.

# Capacity ratings (cont)

HEAT RATING TABLE — NATURAL GAS AND PROPANE

RGV UNIT		GAS HEAT	AL/SS HEAT EXCHANGER		TEMPERATURE RISE (°F)	THERMAL EFFICIENCY (%)	AFUE EFFICIENCY (%)
			INPUT/OUTPUT STAGE 1 (MBH)	INPUT/OUTPUT STAGE 2 (MBH)			
SINGLE PHASE	036	LOW	-/-	65/53	25-55	81	81
		MED	-/-	90/73	45-85	82	81
		HIGH	-/-	—	—	—	—
	048	LOW	-/-	65/53	20-55	81	81
		MED	-/-	90/73	30-65	82	81
		HIGH	-/-	130/106	45-80	81	81
	060	LOW	-/-	65/53	15-55	81	81
		MED	-/-	90/73	25-65	82	81
		HIGH	-/-	130/106	35-80	81	81
THREE PHASE	036	LOW	-/-	67/54	25-55	81	N/A
		MED	82/65	110/93	50-85	80	N/A
		HIGH	—	—	—	—	—
	048	LOW	-/-	67/54	25-55	81	N/A
		MED	-/-	110/88	35-65	80	N/A
		HIGH	120/96	150/120	50-80	80	N/A
	060	LOW	-/-	67/54	20-55	81	N/A
		MED	-/-	110/88	30-65	80	N/A
		HIGH	120/96	150/120	40-80	80	N/A
	072	LOW	-/-	67/54	15-55	81	N/A
		MED	-/-	110/88	25-65	80	N/A
		HIGH	120/96	150/120	30-80	80	N/A

HEAT RATING TABLE — LOW NO<sub>x</sub>

UNIT		GAS HEAT	LOW NO <sub>x</sub> HEAT EXCHANGER		TEMP RISE (°F)	THERMAL EFFICIENCY (%)	AFUE (%)
			INPUT/OUTPUT STAGE 1 (MBH)	INPUT/OUTPUT STAGE 2 (MBH)			
SINGLE PHASE	036	LOW	—	60/49	20-50	82.0	81.3
	048	LOW	—	60/49	20-50	82.0	81.3
	060	LOW	—	60/49	15-50	82.0	81.3
THREE PHASE	036	LOW	—	60/49	20-50	82.0	81.3
	048	LOW	—	60/49	20-50	82.0	81.3
	060	LOW	—	60/49	15-50	82.0	81.3

LEGEND

AFUE — Annual Fuel Utilization Efficiency  
 MBH — Btuh in thousands

# Physical data

## RGV/RAV 3 TO 4 TON PHYSICAL DATA

RGV/RAV UNIT	RGV/RAV036**D/E/F	RGV/RAV036**G	RGV/RAV048**D/E/F	RGV/RAV048**G
<b>NOMINAL TONS</b>	3		4	
<b>BASE UNIT OPERATING WT (lb) RGV/RAV*</b>	482/437		543/498	
<b>REFRIGERATION SYSTEM</b>				
No. Circuits/No. Compressors/Type			1 / 1/ Scroll	
R-410A charge A/B (lbs-oz)	4-6	—	9-14	—
Hot Gas Re-Heat R-410A charge A/B (lbs-oz)	—	7.6	—	14-6
Metering device			Acutrol	
Hot Gas Re-Heat metering device	—	TXV-Acutrol	—	TXV-Acutrol
High-Pressure Trip/Reset (psig)			630/505	
Low-Pressure Trip/Reset (psig)	54/117	27/44	54/117	27/44
<b>EVAPORATOR COIL</b>				
Material (Tube/Fin)			Cu/Al	
Coil Type			3/8-in. RTPF	
Rows/FPI	2/15		3/15	
Total Face Area (ft <sup>2</sup> )			5.5	
Condensate Drain Connection Size			3/4-in.	
<b>CONDENSER COIL</b>				
Material			Cu/Al	
Coil Type			5/16-in. RTPF	
Rows/FPI	1/18		2/18	
Total Face Area (ft <sup>2</sup> )	11.7		15.9	
<b>HOT GAS RE-HEAT COIL</b>				
Material	—	Cu/Al	—	Cu/Al
Coil Type	—	3/8-in. RTPF	—	3/8-in. RTPF
Rows/FPI	—	1/17	—	2/17
Total Face Area (ft <sup>2</sup> )	—	4.1	—	4.1
<b>EVAPORATOR FAN AND MOTOR</b>				
Standard Static 1 Phase				
Motor Qty/Drive Type	1/Direct	—	1/Direct	—
Max Cont BHP	0.44	—	0.72	—
RPM Range	189-1890	—	190-1900	—
Fan Qty/Type	1/Vane Axial	—	1/Vane Axial	—
Fan Diameter (in.)	16.6	—	16.6	—
Medium Static 1 Phase				
Motor Qty/Drive Type	1/Direct	—	1/Direct	—
Max Cont BHP	0.71	—	1.06	—
RPM Range	219-2190	—	217-2170	—
Fan Qty/Type	1/Vane Axial	—	1/Vane Axial	—
Fan Diameter (in.)	16.6	—	16.6	—
High Static 1 Phase				
Motor Qty/Drive Type	1/Direct	—	1/Direct	—
Max Cont BHP	1.07	—	1.53	—
RPM Range	249-2490	—	246-2460	—
Fan Qty/Type	1/Vane Axial	—	1/Vane Axial	—
Fan Diameter (in.)	16.6	—	16.6	—
Standard Static 3 Phase				
Motor Qty/Drive Type			1/Direct	
Max Cont BHP	0.44		0.72	
RPM Range	189-1890		190-1900	
Fan Qty/Type			1/Vane Axial	
Fan Diameter (in.)			16.6	
Medium Static 3 Phase				
Motor Qty/Drive Type			1/Direct	
Max Cont BHP	0.71		1.06	
RPM Range	219-2190		217-2170	
Fan Qty/Type			1/Vane Axial	
Fan Diameter (in.)			16.6	
High Static 3 Phase				
Motor Qty/Drive Type			1/Direct	
Max Cont BHP	1.07		1.96	
RPM Range	249-2490		266-2660	
Fan Qty/Type			1/Vane Axial	
Fan Diameter (in.)			16.6	

# Physical data (cont)

## RGV/RAV 3 TO 4 TON PHYSICAL DATA (cont)

RGV/RAV UNIT	RGV/RAV036**D/E/F	RGV/RAV036**G	RGV/RAV048**D/E/F	RGV/RAV048**G
<b>CONDENSER FAN AND MOTOR</b>				
Qty / Motor Drive Type			1 / Direct	
Motor HP/RPM	1/4 / 1100	1/4 / 1100	1/4 / 1100	1/4 / 1100
Fan Diameter (in.)			23	
<b>FILTERS</b>				
RA Filter Qty / Size (in.)			2 / 16x25x2	
OA Inlet Screen Qty / Size (in.)			1 / 20x24x1	

\* Base unit operating weight does not include weight of options.

### RGV/RAV 5 TO 6 TON PHYSICAL DATA

RGV/RAV UNIT	RGV/RAV060**D/E/F	RGV/RAV060**G	RGV/RAV072**D/E/F	RGV/RAV072**G
<b>NOMINAL TONS</b>	5		6	
<b>BASE UNIT OPERATING WT (lb) RGV/RAV*</b>	556/511		607/562	
<b>REFRIGERATION SYSTEM</b>	1 / 1 / Scroll		1 / 1 / 2-Stage Scroll	
No. Circuits/No. Compressors/Type				
R-410A charge A/B (lbs-oz)	8-9	—	10-3	—
Hot Gas Re-Heat R-410A charge A/B (lbs-oz)	—	15-0	—	20-8
Metering device	Acutrol		TXV	
Hot Gas Re-Heat metering device	—	TXV-Acutrol	—	TXV
High-Pressure Trip/Reset (psig)			630/505	
Low-Pressure Trip/Reset (psig)	54/117	27/44	54/117	27/44
<b>EVAPORATOR COIL</b>				
Material (Tube/Fin)			Cu/Al	
Coil Type			3/8-in. RTPF	
Rows/FPI			4/15	
Total Face Area (ft <sup>2</sup> )	5.5		7.3	
Condensate Drain Connection Size			3/4-in.	
<b>CONDENSER COIL</b>				
Material			Cu/Al	
Coil Type			5/16-in. RTPF	
Rows/FPI			2/18	
Total Face Area (ft <sup>2</sup> )	15.9		15.0	
<b>HOT GAS RE-HEAT COIL</b>				
Material	—	Cu/Al	—	Cu/Al
Coil Type	—	3/8-in. RTPF	—	3/8-in. RTPF
Rows/FPI	—	2/17	—	2/17
Total Face Area (ft <sup>2</sup> )	—	4.1	—	5.5
<b>EVAPORATOR FAN AND MOTOR</b>				
<b>Standard Static 1 Phase</b>				
Motor Qty/Drive Type	1/Direct		—	
Max Cont BHP	1.06		—	
RPM Range	215-2150		—	
Fan Qty/Type	1/Vane Axial		—	
Fan Diameter (in.)	16.6		—	
<b>Medium Static 1 Phase</b>				
Motor Qty/Drive Type	1/Direct		—	
Max Cont BHP	1.44		—	
RPM Range	239-2390		—	
Fan Qty/Type	1/Vane Axial		—	
Fan Diameter (in.)	16.6		—	
<b>Standard Static 3 Phase</b>				
Motor Qty/Drive Type			1/Direct	
Max Cont BHP	1.06		1.31	
RPM Range	215-2150		230-2300	
Fan Qty/Type			1/Vane Axial	
Fan Diameter (in.)			16.6	
<b>Medium Static 3 Phase</b>				
Motor Qty/Drive Type			1/Direct	
Max Cont BHP	1.44		1.76	
RPM Range	239-2390		253-2530	
Fan Qty/Type			1/Vane Axial	
Fan Diameter (in.)			16.6	
<b>High Static 3 Phase</b>				
Motor Qty/Drive Type			1/Direct	
Max Cont BHP			2.43	
RPM Range			284-2836	
Fan Qty/Type			1/Vane Axial	
Fan Diameter (in.)			16.6	
<b>CONDENSER FAN AND MOTOR</b>				
Qty / Motor Drive Type			1 / Direct	
Motor HP/RPM	1/4 / 1100	1/4 / 1100	1/4 / 1100	1/4 / 1100
Fan Diameter (in.)			23	
<b>FILTERS</b>				
RA Filter Qty / Size (in.)	2 / 16x25x2		4 / 16x16x2	
OA Inlet Screen Qty / Size (in.)			1 / 20x24x1	

# Physical data (cont)

## RGV 3 TO 5 TON GAS HEAT DATA — 1 PHASE UNITS

RGV UNIT	RGV036	RGV048	RGV060
<b>GAS CONNECTION</b>			
No. of Gas Valves		1	
Natural Gas Supply Line Pressure (in. wg)/(psig)		4-13 / 0.18-0.47	
Liquid Propane Supply Line Pressure (in. wg)/(psig)		11-13 / 0.40-0.47	
<b>HEAT ANTICIPATOR SETTING (AMPS)</b>			
First Stage		0.14	
Second Stage		0.14	
<b>NATURAL GAS HEAT</b>			
<b>LOW</b>			
No. of Stages / No. of Burners (total)		1 / 2	
Connection Size		1/2-in. NPT	
Rollout Switch Opens / Closes (°F)		195 / 115	
Temperature Rise (°F)	25-55	20-55	15-55
<b>MEDIUM</b>			
No. of Stages / No. of Burners (total)		1 / 3	
Connection Size		1/2-in. NPT	
Rollout Switch Opens / Closes (°F)		195 / 115	
Temperature Rise (°F)	45-85	30-65	25-65
<b>HIGH</b>			
No. of Stages / No. of Burners (total)	—	1 / 3	
Connection Size	—	1/2-in. NPT	
Rollout Switch Opens / Closes (°F)	—	195 / 115	
Temperature Rise (°F)	—	45-80	35-80
<b>LIQUID PROPANE HEAT</b>			
<b>LOW</b>			
No. of Stages / No. of Burners (total)		1 / 2	
Connection Size		1/2-in. NPT	
Rollout Switch Opens / Closes (°F)		195 / 115	
Temperature Rise (°F)	25-55	20-55	15-55
<b>MEDIUM</b>			
No. of Stages / No. of Burners (total)		1 / 3	
Connection Size		1/2-in. NPT	
Rollout Switch Opens / Closes (°F)		195 / 115	
Temperature Rise (°F)	45-85	30-65	25-65
<b>HIGH</b>			
No. of Stages / No. of Burners (total)	—	1 / 3	
Connection Size	—	1/2-in. NPT	
Rollout Switch Opens / Closes (°F)	—	195 / 115	
Temperature Rise (°F)	—	45-80	35-80
<b>LOW NOx GAS HEAT</b>			
<b>LOW</b>			
No. of Stages / No. of Burners (total)		1 / 2	
Connection Size		1/2-in. NPT	
Rollout Switch Opens / Closes (°F)		195 / 115	
Temperature Rise (°F)	20-50		15-50

### LEGEND

**BHP** — Break Horsepower  
**FPI** — Fins Per Inch  
**OA** — Outdoor Air  
**RA** — Return Air

\* Base unit operating weight does not include weight of options.

**RGV 3 TO 6 TON GAS HEAT DATA — 3 PHASE UNITS**

RGV UNIT	RGV036	RGV048	RGV060	RGV072
<b>GAS CONNECTION</b>				
No. of Gas Valves		1		
Natural Gas Supply Line Pressure (in. wg)/(psig)		4-13 / 0.18-0.47		
Liquid Propane Supply Line Pressure (in. wg)/(psig)		11-13 / 0.40-0.47		
<b>HEAT ANTICIPATOR SETTING (AMPS)</b>				
First Stage		0.14		
Second Stage		0.14		
<b>NATURAL GAS HEAT</b>				
LOW				
No. of Stages / No. of Burners (total)		1 / 2		
Connection Size		1/2-in. NPT		
Rollout Switch Opens / Closes (°F)		195 / 115		
Temperature Rise (°F)	25-55		20-55	15-55
MEDIUM				
No. of Stages / No. of Burners (total)	2 / 3		1 / 3	
Connection Size		1/2-in. NPT		
Rollout Switch Opens / Closes (°F)		195 / 115		
Temperature Rise (°F)	50-85	35-65	30-65	25-65
HIGH				
No. of Stages / No. of Burners (total)	—		2 / 3	
Connection Size	—		1/2-in. NPT	
Rollout Switch Opens / Closes (°F)	—		195 / 115	
Temperature Rise (°F)	—	50-80	40-80	35-80
<b>LIQUID PROPANE HEAT</b>				
LOW				
No. of Stages / No. of Burners (total)		1 / 2		
Connection Size		1/2-in. NPT		
Rollout Switch Opens / Closes (°F)		195 / 115		
Temperature Rise (°F)	25-55		20-55	15-55
MEDIUM				
No. of Stages / No. of Burners (total)	2 / 3		1 / 3	
Connection Size		1/2-in. NPT		
Rollout Switch Opens / Closes (°F)		195 / 115		
Temperature Rise (°F)	50-85	35-65	30-65	25-65
HIGH				
No. of Stages / No. of Burners (total)	—		2 / 3	
Connection Size	—		1/2-in. NPT	
Rollout Switch Opens / Closes (°F)	—		195 / 115	
Temperature Rise (°F)	—	50-80	40-80	35-80
<b>LOW NOx GAS HEAT</b>				
LOW				
No. of Stages / No. of Burners (total)		1 / 2		—
Connection Size		1/2-in. NPT		—
Rollout Switch Opens / Closes (°F)		195 / 115		—
Temperature Rise (°F)	20-50		15-50	—

# Options and accessories

ITEM	OPTION*	ACCESSORY†
<b>GAS HEAT (RGV units only)</b>		
Low, Medium or High Gas Heat — Aluminized Heat Exchanger	X	
Low, Medium or High Gas Heat — Stainless Steel Heat Exchanger	X	
Propane Conversion Kit		X
High Altitude Conversion Kit		X
Flue Discharge Deflector		X
Flue Shield		X
<b>ELECTRIC HEAT (RAV units only)</b>		
Electric Resistance Heaters		X
Single Point Kits		X
<b>CABINET</b>		
Thru-the-Base electrical or gas-line connections	X	X
Hinged Access Panels	X	
<b>COIL OPTIONS</b>		
Cu/Cu indoor and/or outdoor coils <sup>1</sup>	X	
Pre-coated outdoor coils <sup>1</sup>	X	
Premium, E-coated outdoor coils <sup>1</sup>	X	
<b>HUMIDITY CONTROL</b>		
Hot Gas Re-Heat Dehumidification System <sup>1</sup>	X	
<b>CONDENSER PROTECTION</b>		
Condenser coil hail guard (louvered design) <sup>1</sup>	X	X
<b>CONTROLS</b>		
Thermostats, temperature sensors, and subbases		X
Smoke detector (supply and/or return air)	X	
Horn Strobe Annunciator <sup>2</sup>		X
Time Guard II compressor delay control circuit		X
Phase Monitor		X
Condensate Overflow switch	X	X

ITEM	OPTION*	ACCESSORY†
<b>ECONOMIZERS AND OUTDOOR AIR DAMPERS</b>		
EconoMiSer® IV for electro-mechanical controls - Non FDD (Standard air leak damper models) <sup>1, 3, 8</sup>	X	X
EconoMiSer X for electro-mechanical controls, complies with FDD (Standard and Ultra Low Leak damper models) <sup>1, 3, 8</sup>	X	X
Motorized 2-position outdoor-air damper <sup>1</sup>	X	X
Manual outdoor-air damper (25% and 50%)		X
Barometric relief <sup>4</sup>	X	X
Power exhaust - prop design		X
<b>ECONOMIZER SENSORS AND IAQ DEVICES</b>		
Single dry bulb temperature sensors <sup>5</sup>	X	X
Differential dry bulb temperature sensors <sup>5</sup>		X
Single enthalpy sensors <sup>5</sup>	X	X
Differential enthalpy sensors <sup>5</sup>		X
CO <sub>2</sub> sensor (wall, duct, or unit mounted) <sup>5</sup>	X	X
<b>INDOOR MOTOR AND DRIVE</b>		
Multiple motor and drive packages	X	
<b>LOW AMBIENT CONTROL</b>		
Winter start kit <sup>6</sup>		X
Low Ambient controller to -20°F (-29°C) <sup>6</sup>		X
<b>POWER OPTIONS</b>		
Convenience outlet (powered) <sup>1</sup>	X	
Convenience outlet (unpowered)	X	
Non-fused disconnect <sup>7</sup>	X	
<b>ROOF CURBS</b>		
Roof curb 14-in. (356 mm)		X
Roof curb 24-in. (610 mm)		X

\* Factory-installed option.

† Field-installed accessory.

## NOTES:

- Not available on single phase (-K voltage code) models. Use field-installed accessory where available.
- Requires a field-supplied 24V transformer for each application. See price pages for details.
- FDD (Fault Detection and Diagnostic) capability per California Title 24 section 120.2.
- Included with economizer.
- Sensors used to optimize economizer performance.
- See application data for assistance.
- Non-fused disconnect switch cannot be used when unit electrical rating exceeds:  
208-230/1/60 and 208-230/3/60 = 80 amps (FLA).  
480/3/60 and 575/3/60 = 80 amps (FLA).
- Available as a factory-installed option for 036-060 models only.

## **Factory-installed options**

### **Economizer (dry-bulb or enthalpy)**

Economizers save money. They bring in fresh, outside air for ventilation; and provide cool, outside air to cool your building. This is the preferred method of low-ambient cooling. When coupled to CO<sub>2</sub> sensors, economizers can provide even more savings by coupling the ventilation air to only that amount required.

Economizers are available, installed and tested by the factory, with either enthalpy or dry-bulb temperature inputs. Additional sensors are available as accessories to optimize the economizers. Economizers include a powered exhaust system to help equalize building pressures.

Economizers include gravity controlled barometric relief that helps equalize building pressure and ambient air pressures. This can be a cost effective solution to prevent building pressurization. Economizers are available in Ultra Low Leak and standard low leak versions. Economizers can be factory-installed or easily field-installed.

### **Unit mounted CO<sub>2</sub> sensor**

The CO<sub>2</sub> sensor works with the economizer to intake only the correct amount of outside air for ventilation. As occupants fill your building, the CO<sub>2</sub> sensor detects their presence through increasing CO<sub>2</sub> levels, and opens the economizer appropriately. When the occupants leave, the CO<sub>2</sub> levels decrease, and the sensor appropriately closes the economizer. This intelligent control of the ventilation air, called demand controlled ventilation (DCV), reduces the overall load on the rooftop, saving money. It is also available as a field-installed accessory.

### **Smoke detector (supply and/or return air)**

Trust the experts. Smoke detectors make your application safer and your job easier. ICP smoke detectors immediately shut down the rooftop unit when smoke is detected. They are available, installed by the factory, for supply air, return air, or both.

### **Optional Hot Gas Re-Heat dehumidification system**

ICP's Hot Gas Re-Heat dehumidification system is an all-inclusive factory-installed option that can be ordered with any RGV/RAV036-072 rooftop unit, with the exception of single phase voltage (208-230/1/60) units.

This system expands the envelope of operation of ICP's rooftop products to provide unprecedented flexibility to meet year round comfort conditions.

The Hot Gas Re-Heat dehumidification system has a unique dual operational mode setting. The Hot Gas Re-Heat system provides greater dehumidification of the occupied space by two modes of dehumidification operations in addition to its normal design cooling mode.

The RGV/RAV036-072 rooftop, coupled with the Hot Gas Re-Heat system, is capable of operating in normal design cooling mode, sub-cooling mode, and hot gas reheat mode. Normal design cooling mode is when the unit will operate under its normal sequence of operation by cycling compressors to maintain comfort conditions.

Sub-cooling mode will operate to satisfy part load type conditions when the space requires combined sensible and a higher proportion of latent load control. Hot Gas

Reheat mode will operate when outdoor temperatures diminish and the need for latent capacity is required for sole humidity control. Hot Gas Reheat mode will provide neutral air for maximum dehumidification operation.

NOTE: Hot Gas Re-Heat system includes Low Ambient controller.

### **Thru-the-base connections**

Thru-the-base connections, available as a factory option, are necessary to ensure proper connection and seal when routing wire and piping through the rooftop's base-pan and curb. These couplings eliminate roof penetration and should be considered for gas lines, main power lines, as well as control power.

### **Hinged access panels**

Allows access to unit's major components with specifically designed hinged access panels. Panels are filter, control box access indoor fan motor access.

### **Cu/Cu (indoor) coils**

Copper fins and copper tubes are mechanically bonded to copper tubes and copper tube sheets. A polymer strip prevents coil assembly from contacting the sheet metal coil pan to minimize potential for galvanic corrosion between coil and pan.

### **E-coated (outdoor and indoor) coils**

A flexible epoxy polymer coating uniformly applied to all coil surface areas without material bridging between fins. Coating process shall ensure complete coil encapsulation of tubes, fins and headers.

### **Pre-coated outdoor coils**

A durable epoxy-phenolic coating to provide protection in mildly corrosive coastal environments. The coating minimizes galvanic action between dissimilar metals. Coating is applied to the aluminum fin stock prior to the fin stamping process to create an inert barrier between the aluminum fin and copper tube.

### **Condenser coil hail guard**

Sleek, louvered panels protect the condenser coil from hail damage, foreign objects, and incidental contact.

### **Single enthalpy sensor**

Prevents the wheel from rotating if the outside air conditions are acceptable for free cooling. Both exhaust and supply blowers will remain on.

### **Stainless steel heat exchanger (RGV units only)**

The stainless steel heat exchanger option provides the tubular heat exchanger be made out of a minimum 20 gage type 409 stainless steel for applications where the mixed air to the heat exchanger is expected to drop below 45°F (7°C). Stainless steel may be specified on applications where the presence of airborne contaminants require its use (applications such as paper mills) or in area with very high outdoor humidity that may result in severe condensation in the heat exchanger during cooling operation.

### **Convenience outlet (powered or un-powered)**

Reduce service and/or installation costs by including a convenience outlet in your specification. ICP will install

## Options and accessories (cont)

this service feature at our factory. Provides a convenient, 15 amp, 115v GFCI receptacle with “Wet in Use” cover. The “powered” option allows the installer to power the outlet from the line side of the disconnect or load side as required by code. The “unpowered” option is to be powered from a separate 115/120v power source.

The unpowered convenience outlet is available as a 15 amp factory-installed option or a 20 amp field-installed accessory.

### **Non-fused disconnect**

This OSHA-compliant, factory-installed, safety switch allows a service technician to locally secure power to the rooftop. When selecting a factory-installed non-fused disconnect, note they are sized for the unit as ordered from the factory. The sizing of these do not accommodate field-installed items such as power exhaust devices, etc. If field installing electric heat with factory-installed non-fused disconnect switch, a single point kit may or may not be required.

### **Condensate overflow switch**

This sensor and related controller monitors the condensate level in the drain pan and shuts down compression operation when overflow conditions occur. It includes:

- Indicator light – solid red (more than 10 seconds on water contact – compressors disabled), blinking red (sensor disconnected)
- 10 second delay to break – eliminates nuisance trips from splashing or waves in pan (sensor needs 10 seconds of constant water contact before tripping)
- Disables the compressor(s) operation when condensate plug is detected, but still allows fans to run for economizer.

### **Power exhaust with barometric relief**

Superior internal building pressure control. This field-installed accessory may eliminate the need for costly, external pressure control fans.

## Field-installed accessories

### Condenser coil hail guard

Sleek, louvered panels protect the condenser coil from hail damage, foreign objects, and incidental contact. This can be purchased as a factory-installed option or as a field-installed accessory.

### Differential enthalpy sensor

The differential enthalpy sensor is comprised of an outdoor and return air enthalpy sensors to provide differential enthalpy control. The sensor allows the unit to determine if outside air is suitable for free cooling.

### Wall or duct mounted CO<sub>2</sub> sensor

The IAQ sensor shall be available in duct or wall mount. The sensor provides demand ventilation indoor air quality (IAQ) control.

### Propane conversion kit (RGV units only)

Convert your gas heat rooftop from standard natural gas operation to propane using this field-installed kit.

### High altitude conversion kit (RGV units only)

High altitudes have less oxygen, which affects the fuel/air mixture in heat exchangers. In order to maintain a proper fuel/air mixture, heat exchangers operating in altitudes above 2000 ft (610 m) require different orifices. To select the correct burner orifices or determine the heat capacity for a high altitude application, use either the selection software, or the unit's service manual. High altitudes have less oxygen, which means heat exchangers need less fuel. The new gas orifices in this field-installed kit make the necessary adjustment for high altitude applications. They restore the optimal fuel to air mixture and maintain healthy combustion on altitudes above 2000 ft (610 m).

NOTE: Typical natural gas heating value ranges from 975 to 1050 Btu/ft<sup>3</sup> at sea level nationally. The heating value goes down approximately 1.7% per every thousand feet elevation. Standard factory orifices can typically be used up to 2000 ft (610 m) elevation without any operational issues.

### Flue discharge deflector (RGV units only)

The flue discharge deflector is a useful accessory when flue gas recirculation is a concern. By venting the flue discharge upwards, the deflector minimizes the chance for a neighboring unit to intake the flue exhaust.

### Phase monitor protection

The Phase Monitor Control will monitor the sequence of three phase electrical system to provide a phase reversal protection; and monitor the three phase voltage inputs to provide a phase loss protection for the three phase device. It will work on either a Delta or Wye power connection.

### Winter start kit

The winter start kit by ICP extends the low ambient limit of your rooftop to 25°F (−4°C). The kit bypasses the low

pressure switch, preventing nuisance tripping of the low pressure switch. Other low ambient precautions may still be prudent.

### Low ambient controller

The low ambient controller is a head pressure controller kit that is designed to maintain the unit's condenser head pressure during periods of low ambient cooling operation. This device should be used as an alternative to economizer free cooling when economizer usage is either not appropriate or desired. The low ambient controller will either cycle the outdoor fan motors or operate them at reduced speed to maintain the unit operation, depending on the model. This controller allows cooling operation down to −20°F (−29°C) ambient conditions.

### Roof curb (14-in./356 mm or 24-in./610 mm)

Full perimeter roof curb with exhaust capability provides separate air streams for energy recovery from the exhaust air without supply air contamination.

### Filter status indicator accessory

Monitors static pressure across supply and exhaust filters and provides indication when filters become clogged.

### Power exhaust

Superior internal building pressure control. This field-installed accessory may eliminate the need for costly, external pressure control fans.

### Manual OA Damper

Manual outdoor air dampers are an economical way to bring in ventilation air. The dampers are available in 25% and 50% versions.

NOTE: See application tip "ROOFTOP-18-01" prior to use of this damper on 072 size models.

### Motorized 2-Position Damper

The ICP 2-position, motorized outdoor air damper admits up to 100% outside air. Using reliable, gear-driven technology, the 2-position damper opens to allow ventilation air and closes when the rooftop stops, stopping unwanted infiltration.

NOTE: See application tip "ROOFTOP-18-01" prior to use of this damper on 072 size models.

### Electric Heaters

ICP offers a full-line of field-installed accessory heaters. The heaters are very easy to use, install and are all pre-engineered and certified.

### Time Guard II control circuit

This accessory protects your compressor by preventing short-cycling in the event of some other failure, prevents the compressor from restarting for 30 seconds after stopping. Not required with authorized commercial thermostats.

# Options and accessories (cont)

## OPTIONS AND ACCESSORY WEIGHTS

OPTION / ACCESSORY NAME	RGV/RAV UNIT WEIGHT							
	036		048		060		072	
	lb	kg	lb	kg	lb	kg	lb	kg
Hot Gas Re-Heat System*	15	7	15	7	15	7	24	11
Power Exhaust - vertical	51	23	51	23	51	23	51	23
Power Exhaust - horizontal	39	18	39	18	39	18	39	18
EconoMi\$er® (X, IV)	35	16	35	16	35	16	35	16
2-Position Damper	39	18	39	18	39	18	58	26
Manual Damper	12	5	12	5	12	5	18	8
Medium Gas Heat (RGV units only)	9	4	9	4	9	4	15	7
High Gas Heat (RGV units only)	—	—	63	29	63	29	63	29
Hail Guard (louvered)	13	6	13	6	13	6	17	8
Cu/Cu Condenser Coil	37	17	74	34	74	34	95	43
Cu/Cu Condenser and Evaporator Coils	75	34	112	51	112	51	165	75
Roof Curb (14-in. curb)	95	43	95	43	95	43	95	43
Roof Curb (24-in. curb)	150	68	150	68	150	68	150	68
CO <sub>2</sub> sensor	2	1	2	1	2	1	2	1
Flue Discharge Deflector	7	3	7	3	7	3	7	3
Optional Indoor Motor/Drive	10	5	10	5	10	5	15	7
Low Ambient Controller	9	4	9	4	9	4	9	4
Winter Start Kit	5	2	5	2	5	2	5	2
Return Air Smoke Detector	7	3	7	3	7	3	7	3
Supply Air Smoke Detector	7	3	7	3	7	3	7	3
Fan Filter Switch	2	1	2	1	2	1	2	1
Non-Fused Disconnect	15	7	15	7	15	7	15	7
Powered Convenience Outlet	36	16	36	16	36	16	36	16
Unpowered Convenience Outlet	4	2	4	2	4	2	4	2
Enthalpy Sensor	2	1	2	1	2	1	2	1
Differential Enthalpy Sensor	3	1	3	1	3	1	3	1

### LEGEND

—Not Available

\*For Hot Gas Re-Heat system, add Low Ambient controller weight.

NOTE: Where multiple variations are available, the heaviest combination is listed.

# Base unit dimensions

## RGV036-072 BASE UNIT DIMENSIONS

**ICP**  
THIS DOCUMENT IS THE PROPERTY OF UTC CLIMATE CONTROLS. SUBMISSION OF THESE DRAWINGS OR DOCUMENTS WITHOUT WRITTEN CONSENT. THE CONTENTS WILL NOT BE DISCLOSED OR USED IN ANY MANNER WITHOUT WRITTEN CONSENT.

UNIT	J	K
RGV036	33-3/8 [847]	18-5/8 [472]
RGV048	33-3/8 [847]	14-7/8 [377]
RGV060	33-3/8 [847]	14-7/8 [377]
RGV072	33-3/8 [847]	18-5/8 [472]

- NOTES:
1. DIMENSIONS ARE IN INCHES. DIMENSIONS IN [ ] ARE IN MILLIMETERS.
  2. CENTER OF GRAVITY
  3. DIRECTION OF AIR FLOW
  4. ALL VIEW DRAWN USING 3RD ANGLE

CONNECTION SIZES	
A	1-3/8" (35) DIA. FIELD POWER SUPPLY HOLE
B	2" (50) DIA. POWER SUPPLY KNOCKOUT
C	1-3/4" (51) DIA. GAUGE ACCESS PLUG
D	7/8" (22) DIA. FIELD CONTROL WIRING HOLE
E	3/4" - 14 NPT. CONDENSATE DRAIN
F	1/2" - 14 NPT. GAS CONNECTION
G	2-1/2" (64) DIA. POWER SUPPLY KNOCK-OUT

THRU-THE-BASE CHART FOR USE WITH THE CONDENSATE DRAIN (SEE DRAWING 008A001, 009A000)	
W	THREADED CONDUIT SIZE
X	WIRE SIZE (INCHES)
Y	REC'D HOLE SIZE (INCHES)
Z*	POWER USE SIZES (MMK...)

FOR "THRU-THE-BASEPAN" FACTORY OPTION, FITTINGS FOR ONLY X, Y, & Z ARE PROVIDED. (1008A00) PROVIDES 3/4" FPT THRU CURB FLANGE & FITTING.

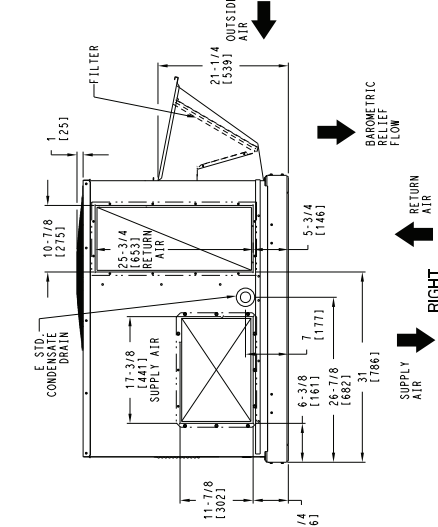
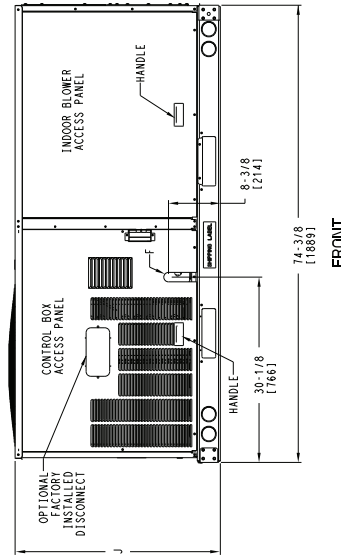
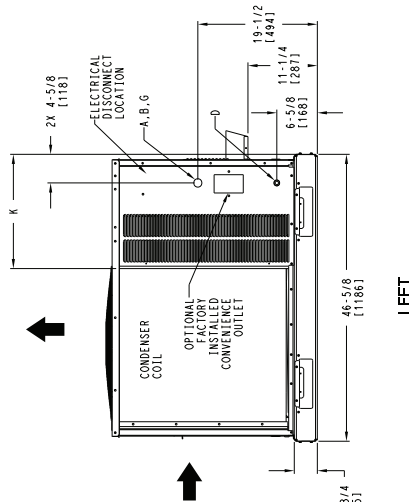
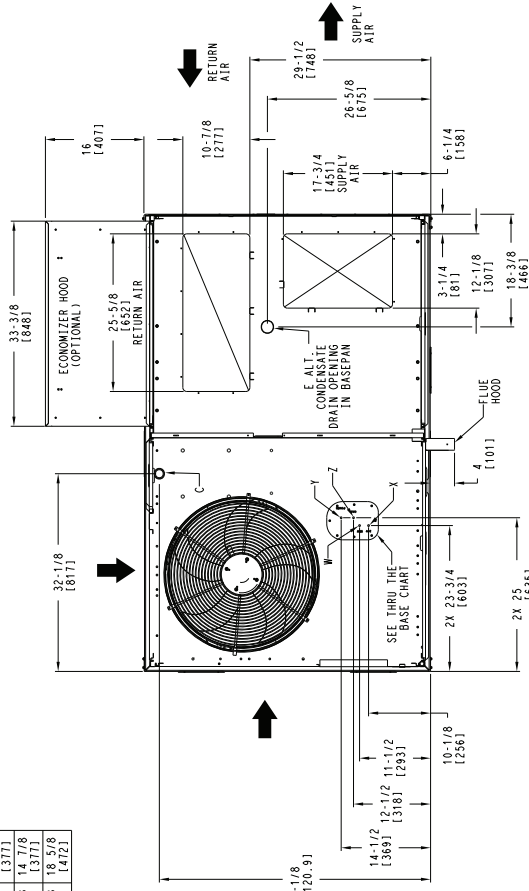

ITC CLASSIFICATION	SHEET	DATE	SUPERCEDES	REV
U.S. ECCN: NSR	1 OF 3	04/03/19	10/25/18	C
RGV 036 - 072 SINGLE PACKAGE ELECTRICAL COOLING WITH GAS HEAT				48TC003097



# RGV036-072 BASE UNIT DIMENSIONS (cont)



THIS DOCUMENT IS THE PROPERTY OF ITC CLIMATE CONTROLS. SUBMISSION OF THESE DRAWINGS OR DOCUMENTS TO ANY OTHER PARTY WITHOUT THE WRITTEN CONSENT OF ITC CLIMATE CONTROLS DOES NOT CONSTITUTE PART PERFORMANCE OR ACCEPTANCE OF CONTRACT.

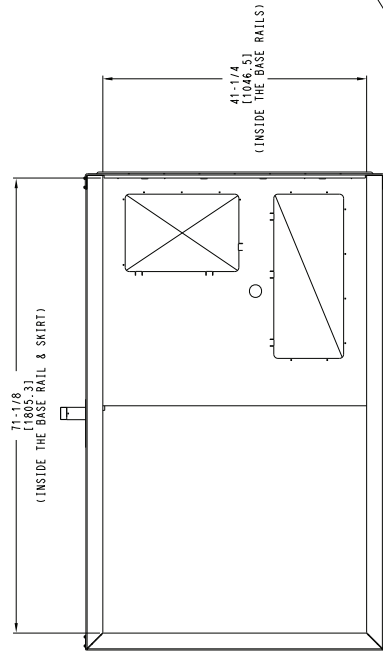
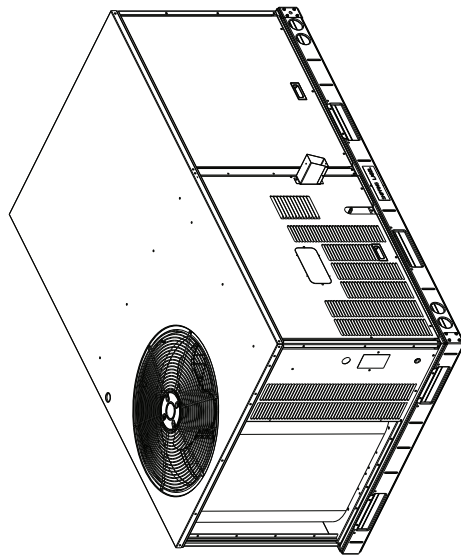

INSIDE BASERAIL DIMENSIONS

BOTTOM

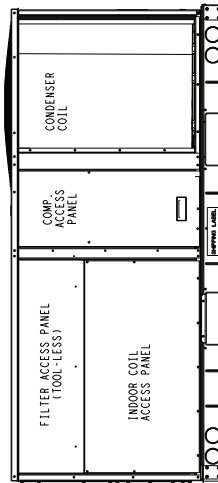
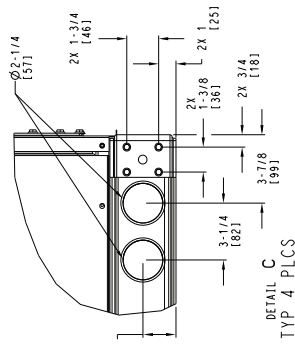

BACK

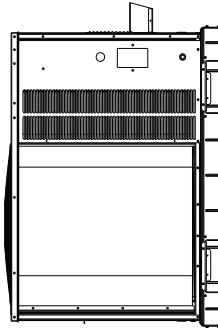

LEFT

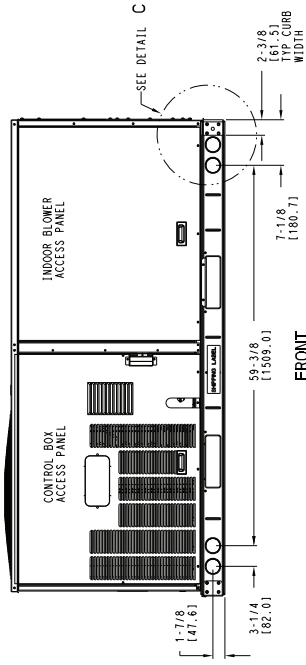

FRONT

ITC CLASSIFICATION U.S. ECCN: NSR	SHEET 3 OF 3	DATE 04/03/19	SUPERCEDES 10/25/18	RGV 036 - 072 SINGLE PACKAGE ELECTRICAL COOLING WITH GAS HEAT	REV 48TC003097 C
--------------------------------------	-----------------	------------------	------------------------	--	------------------------



# RAV036-072 BASE UNIT DIMENSIONS (cont)

UNIT	CORNER A		CORNER B		CORNER C		CORNER D		C. G.			HEIGHT		
	WEIGHT (LBS.)	WEIGHT (KG.)	WEIGHT (LBS.)	WEIGHT (KG.)	WEIGHT (LBS.)	WEIGHT (KG.)	WEIGHT (LBS.)	WEIGHT (KG.)	X	Y	Z			
RAV036	437	198	110	50	107	49	108	49	112	51	36 5/8 [920]	23 9/16 [598]	18 1/2 [470]	7
RAV048	498	226	136	62	124	56	114	52	125	57	35 1/2 [902]	22 3/8 [568]	18 1/4 [464]	
RAV060	511	232	139	63	127	58	117	53	128	58	33 1/2 [852]	22 3/8 [568]	18 1/4 [464]	
RAV072	562	255	154	70	131	62	121	56	143	65	35 [889]	22 1/2 [571]	19 1/2 [493]	

\* STANDARD UNIT WEIGHT IS WITHOUT ELECTRIC HEAT AND WITHOUT PACKAGING.  
 FOR OTHER OPTIONS AND ACCESSORIES, REFER TO THE PRODUCT DATA CATALOG.

**ICP**  
 THIS DOCUMENT IS THE PROPERTY OF UTC CLIMATE CONTROLS. SUBMISSION OF THESE DRAWINGS OR DOCUMENTS WITHOUT WRITTEN CONSENT OF ICP DOES NOT CONSTITUTE AN AGREEMENT THAT THE CONTENTS WILL NOT BE DISCLOSED OR USED WITHOUT WRITTEN CONSENT.

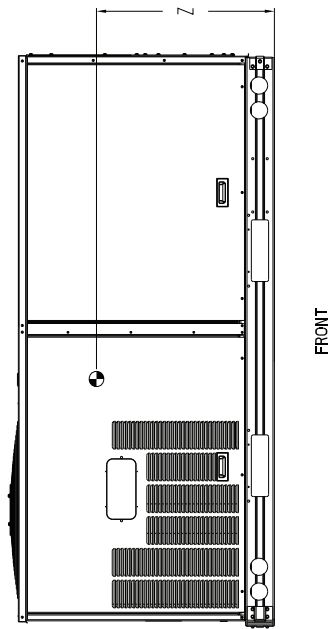
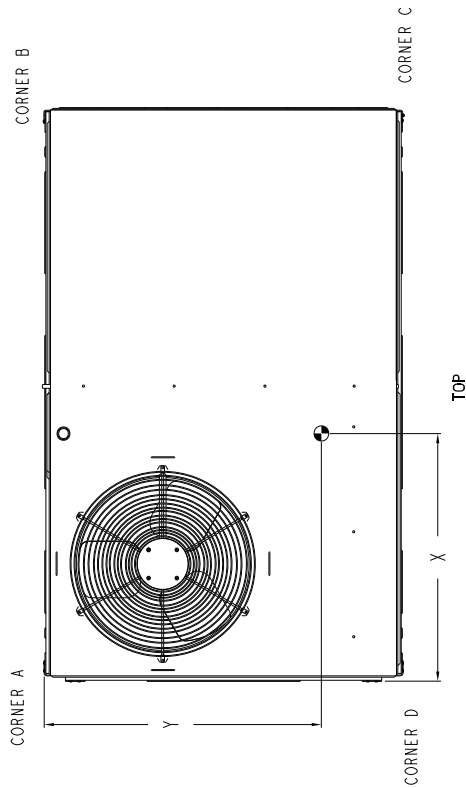
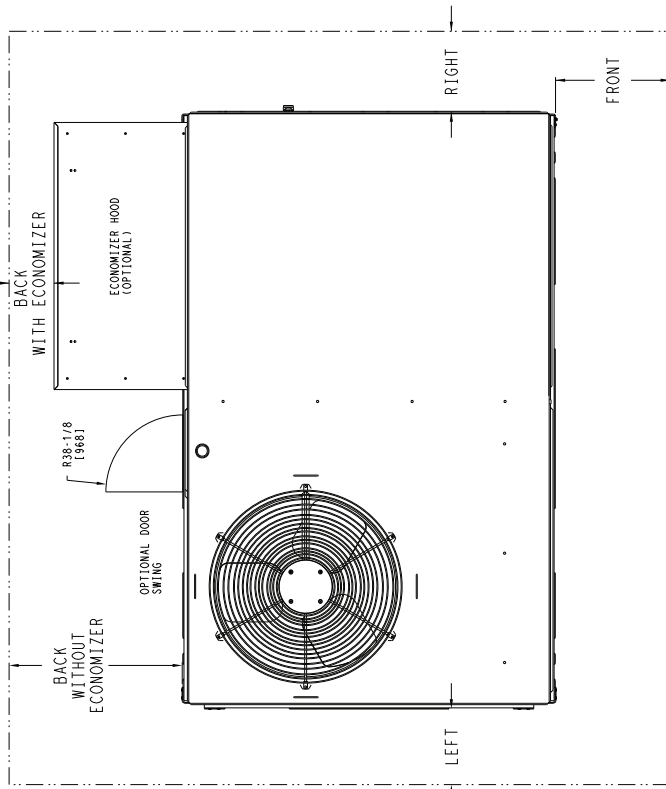

NOTE:  
 1. FOR ALL MINIMUM CLEARANCES LOCAL CODES OR JURISDICTIONS MAY PREVAIL.

SURFACE	CLEARANCE		OPERATING CLEARANCE
	SERVICE WITH CONDUCTIVE BARRIER	SERVICE WITH NONCONDUCTIVE BARRIER	
FRONT	48 [1219mm]	36 [914mm]	18 [457mm]
LEFT	48 [1219mm]	42 [1067mm]	18 [457mm]
BACK W/O HOOD	48 [1219mm]	42 [1067mm]	18 [457mm]
BACK W/ HOOD	36 [914mm]	36 [914mm]	18 [457mm]
RIGHT	36 [914mm]	36 [914mm]	18 [457mm]
TOP	72 [1829mm]	72 [1829mm]	72 [1829mm]

ITC CLASSIFICATION	SHEET	DATE	REV
U.S. ECCN: NSR	2 OF 3	03/21/19	C
RAV 036 - 072 SINGLE PACKAGE ELECTRICAL COOLING WITH ELECTRIC HEAT			48TC003098

# Base unit dimensions (cont)

## RAV036-072 BASE UNIT DIMENSIONS (cont)

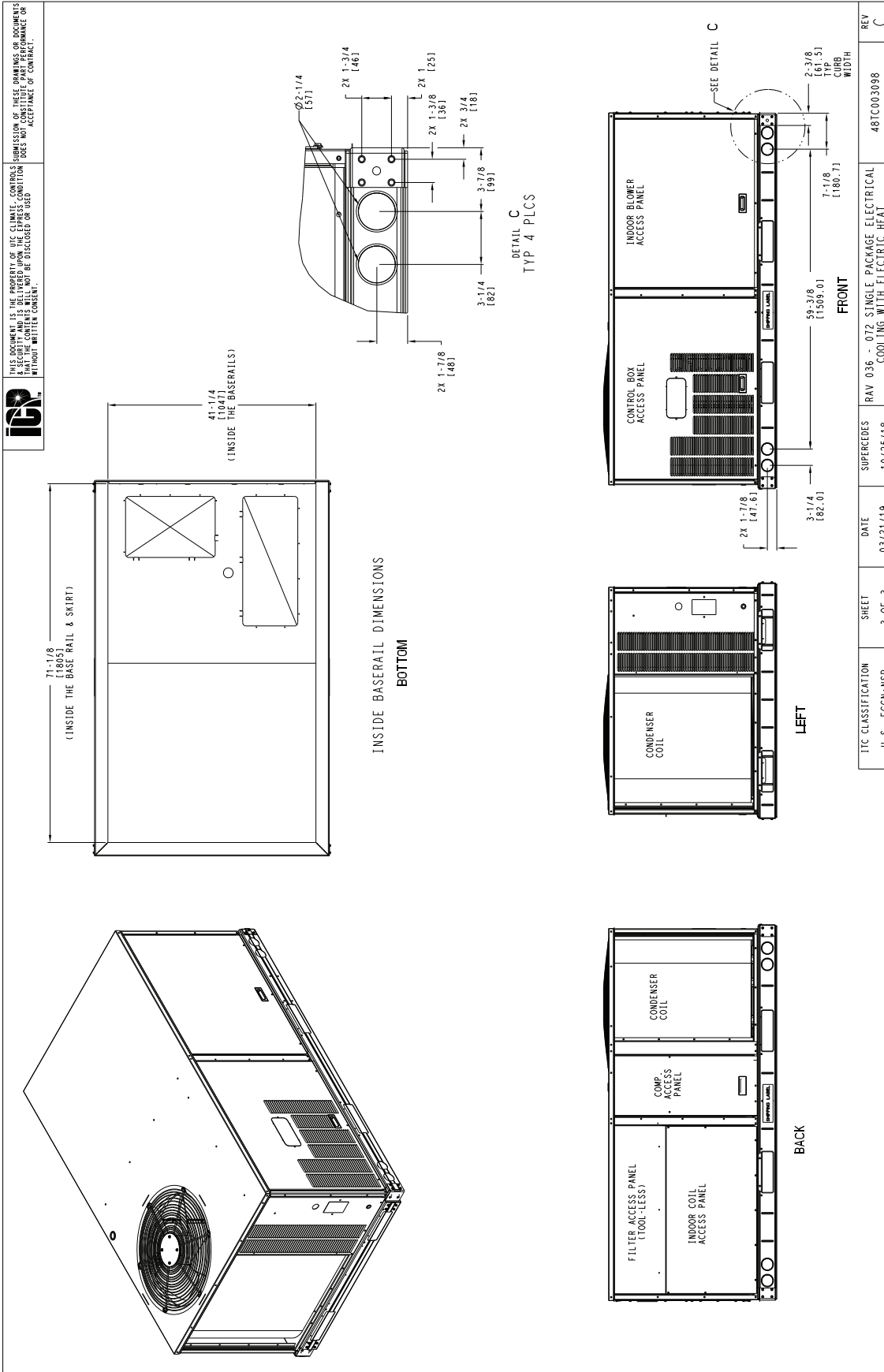

# Accessory dimensions

## ROOF CURB DIMENSIONS — RGV/RAV036-072

CONNECTOR PKG. ACC.	GAS CONNECTION TYPE	GAS FITTING	POWER WIRING FITTING	CONTROL WIRING FITTING	ACCESSORY CONVENIENCE OUTLET WIRING CONNECTOR
CRBTMPWR001A01	THRU THE CURB	3/4" [19] NPT	3/4" [19] NPT	1/2" [12.7] NPT	1/2" [12.7] NPT
CRBTMPWR003A01	THRU THE BOTTOM	1/2" [12.7] NPT			

- NOTES:  
 1. THIS CURB ACCESSORY IS SHIPPED DISASSEMBLED.  
 2. INSULATED PANELS: 25.4 [1] THK POLYURETHANE FOAM, 44.5 [1.34] # DENSITY.  
 3. DIMENSIONS IN [ ] ARE IN MILLIMETERS.  
 4. ROOF CURB: 18 GAGE STEEL.  
 5. ATTACH TO WORK SURFACE WITH ANGLE BRACKET ON EACH SIDE.  
 6. DIRECTION OF AIR FLOW.  
 7. ZZZZZZ DIRECTION OF AIR FLOW.  
 8. CONNECTOR PACKAGE CRBTMPWR001A01 IS FOR THRU-THE-CURB GAS TYPE PACKAGE CRBTMPWR003A01 IS FOR THRU-THE-BOTTOM TYPE GAS CONNECTIONS.

ROOF CURB ACCESSORY #	A
CRRFCURB001A01	14" [356]
CRRFCURB002A01	24" [610]

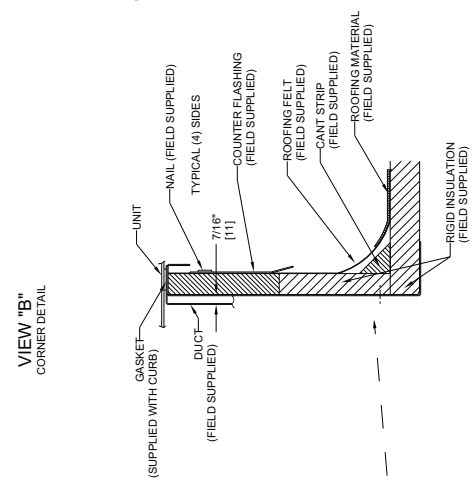
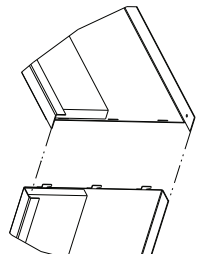
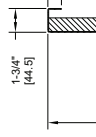
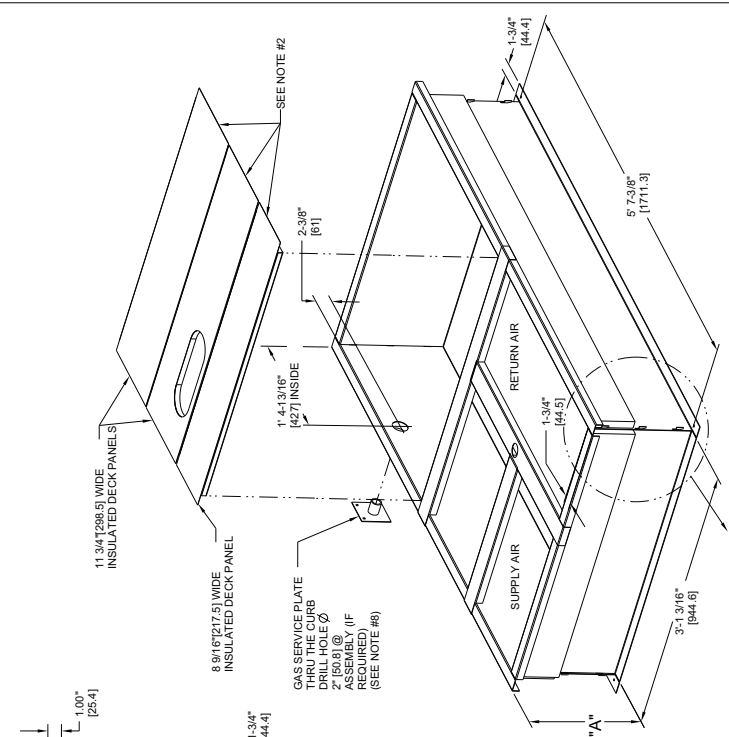

CERTIFIED DRAWING

DRAWING RELEASE LEVEL:		PRODUCTION		TITLE	
THIRD ANGLE PROJECTION	UNLESS OTHERWISE SPECIFIED DIMENSIONS ARE IN INCHES	ENGINEERS	MANUFACTURERS	SEE DRAWING NUMBER	REV
MATERIAL	TOLERANCES ON:	DRAWERS	CHECKER	D	48TC400427
	1 DEC ±	ENGINEERS	MANUFACTURERS	DATE DRAWING	SHEET 5 OF 5
	2 DEC ±	DRAWERS	CHECKER	48TC400427	DISTRIBUTION
	3 DEC ±	ENGINEERS	MANUFACTURERS	DATE DRAWING	SCALE
	4 DEC ±	DRAWERS	CHECKER	48TC400427	NA
	5 DEC ±	ENGINEERS	MANUFACTURERS	DATE DRAWING	MMC
	6 DEC ±	DRAWERS	CHECKER	48TC400427	
	7 DEC ±	ENGINEERS	MANUFACTURERS	DATE DRAWING	
	8 DEC ±	DRAWERS	CHECKER	48TC400427	
	9 DEC ±	ENGINEERS	MANUFACTURERS	DATE DRAWING	
	10 DEC ±	DRAWERS	CHECKER	48TC400427	
	11 DEC ±	ENGINEERS	MANUFACTURERS	DATE DRAWING	
	12 DEC ±	DRAWERS	CHECKER	48TC400427	
	13 DEC ±	ENGINEERS	MANUFACTURERS	DATE DRAWING	
	14 DEC ±	DRAWERS	CHECKER	48TC400427	
	15 DEC ±	ENGINEERS	MANUFACTURERS	DATE DRAWING	
	16 DEC ±	DRAWERS	CHECKER	48TC400427	
	17 DEC ±	ENGINEERS	MANUFACTURERS	DATE DRAWING	
	18 DEC ±	DRAWERS	CHECKER	48TC400427	
	19 DEC ±	ENGINEERS	MANUFACTURERS	DATE DRAWING	
	20 DEC ±	DRAWERS	CHECKER	48TC400427	
	21 DEC ±	ENGINEERS	MANUFACTURERS	DATE DRAWING	
	22 DEC ±	DRAWERS	CHECKER	48TC400427	
	23 DEC ±	ENGINEERS	MANUFACTURERS	DATE DRAWING	
	24 DEC ±	DRAWERS	CHECKER	48TC400427	
	25 DEC ±	ENGINEERS	MANUFACTURERS	DATE DRAWING	
	26 DEC ±	DRAWERS	CHECKER	48TC400427	
	27 DEC ±	ENGINEERS	MANUFACTURERS	DATE DRAWING	
	28 DEC ±	DRAWERS	CHECKER	48TC400427	
	29 DEC ±	ENGINEERS	MANUFACTURERS	DATE DRAWING	
	30 DEC ±	DRAWERS	CHECKER	48TC400427	
	31 DEC ±	ENGINEERS	MANUFACTURERS	DATE DRAWING	
	32 DEC ±	DRAWERS	CHECKER	48TC400427	
	33 DEC ±	ENGINEERS	MANUFACTURERS	DATE DRAWING	
	34 DEC ±	DRAWERS	CHECKER	48TC400427	
	35 DEC ±	ENGINEERS	MANUFACTURERS	DATE DRAWING	
	36 DEC ±	DRAWERS	CHECKER	48TC400427	
	37 DEC ±	ENGINEERS	MANUFACTURERS	DATE DRAWING	
	38 DEC ±	DRAWERS	CHECKER	48TC400427	
	39 DEC ±	ENGINEERS	MANUFACTURERS	DATE DRAWING	
	40 DEC ±	DRAWERS	CHECKER	48TC400427	
	41 DEC ±	ENGINEERS	MANUFACTURERS	DATE DRAWING	
	42 DEC ±	DRAWERS	CHECKER	48TC400427	
	43 DEC ±	ENGINEERS	MANUFACTURERS	DATE DRAWING	
	44 DEC ±	DRAWERS	CHECKER	48TC400427	
	45 DEC ±	ENGINEERS	MANUFACTURERS	DATE DRAWING	
	46 DEC ±	DRAWERS	CHECKER	48TC400427	
	47 DEC ±	ENGINEERS	MANUFACTURERS	DATE DRAWING	
	48 DEC ±	DRAWERS	CHECKER	48TC400427	
	49 DEC ±	ENGINEERS	MANUFACTURERS	DATE DRAWING	
	50 DEC ±	DRAWERS	CHECKER	48TC400427	
	51 DEC ±	ENGINEERS	MANUFACTURERS	DATE DRAWING	
	52 DEC ±	DRAWERS	CHECKER	48TC400427	
	53 DEC ±	ENGINEERS	MANUFACTURERS	DATE DRAWING	
	54 DEC ±	DRAWERS	CHECKER	48TC400427	
	55 DEC ±	ENGINEERS	MANUFACTURERS	DATE DRAWING	
	56 DEC ±	DRAWERS	CHECKER	48TC400427	
	57 DEC ±	ENGINEERS	MANUFACTURERS	DATE DRAWING	
	58 DEC ±	DRAWERS	CHECKER	48TC400427	
	59 DEC ±	ENGINEERS	MANUFACTURERS	DATE DRAWING	
	60 DEC ±	DRAWERS	CHECKER	48TC400427	
	61 DEC ±	ENGINEERS	MANUFACTURERS	DATE DRAWING	
	62 DEC ±	DRAWERS	CHECKER	48TC400427	
	63 DEC ±	ENGINEERS	MANUFACTURERS	DATE DRAWING	
	64 DEC ±	DRAWERS	CHECKER	48TC400427	
	65 DEC ±	ENGINEERS	MANUFACTURERS	DATE DRAWING	
	66 DEC ±	DRAWERS	CHECKER	48TC400427	
	67 DEC ±	ENGINEERS	MANUFACTURERS	DATE DRAWING	
	68 DEC ±	DRAWERS	CHECKER	48TC400427	
	69 DEC ±	ENGINEERS	MANUFACTURERS	DATE DRAWING	
	70 DEC ±	DRAWERS	CHECKER	48TC400427	
	71 DEC ±	ENGINEERS	MANUFACTURERS	DATE DRAWING	
	72 DEC ±	DRAWERS	CHECKER	48TC400427	
	73 DEC ±	ENGINEERS	MANUFACTURERS	DATE DRAWING	
	74 DEC ±	DRAWERS	CHECKER	48TC400427	
	75 DEC ±	ENGINEERS	MANUFACTURERS	DATE DRAWING	
	76 DEC ±	DRAWERS	CHECKER	48TC400427	
	77 DEC ±	ENGINEERS	MANUFACTURERS	DATE DRAWING	
	78 DEC ±	DRAWERS	CHECKER	48TC400427	
	79 DEC ±	ENGINEERS	MANUFACTURERS	DATE DRAWING	
	80 DEC ±	DRAWERS	CHECKER	48TC400427	
	81 DEC ±	ENGINEERS	MANUFACTURERS	DATE DRAWING	
	82 DEC ±	DRAWERS	CHECKER	48TC400427	
	83 DEC ±	ENGINEERS	MANUFACTURERS	DATE DRAWING	
	84 DEC ±	DRAWERS	CHECKER	48TC400427	
	85 DEC ±	ENGINEERS	MANUFACTURERS	DATE DRAWING	
	86 DEC ±	DRAWERS	CHECKER	48TC400427	
	87 DEC ±	ENGINEERS	MANUFACTURERS	DATE DRAWING	
	88 DEC ±	DRAWERS	CHECKER	48TC400427	
	89 DEC ±	ENGINEERS	MANUFACTURERS	DATE DRAWING	
	90 DEC ±	DRAWERS	CHECKER	48TC400427	
	91 DEC ±	ENGINEERS	MANUFACTURERS	DATE DRAWING	
	92 DEC ±	DRAWERS	CHECKER	48TC400427	
	93 DEC ±	ENGINEERS	MANUFACTURERS	DATE DRAWING	
	94 DEC ±	DRAWERS	CHECKER	48TC400427	
	95 DEC ±	ENGINEERS	MANUFACTURERS	DATE DRAWING	
	96 DEC ±	DRAWERS	CHECKER	48TC400427	
	97 DEC ±	ENGINEERS	MANUFACTURERS	DATE DRAWING	
	98 DEC ±	DRAWERS	CHECKER	48TC400427	
	99 DEC ±	ENGINEERS	MANUFACTURERS	DATE DRAWING	
	100 DEC ±	DRAWERS	CHECKER	48TC400427	

REVISION	DATE	BY	CHKD	APPD	ENGR.	REVISION RECORD
A	04/23/13	MMC			1067688	OVERALL DIM. 6.73\"/>

# Performance data

## RGV/RAV036 SINGLE STAGE COOLING CAPACITIES

RGV/RAV036				AMBIENT TEMPERATURE (F)												
				85			95			105			115			
				EAT (db)			EAT (db)			EAT (db)			EAT (db)			
				75	80	85	75	80	85	75	80	85	75	80	85	
900 Cfm	EAT (wb)	58	TC	28.6	28.6	32.5	27.0	27.0	30.7	25.2	25.2	28.6	23.2	23.2	26.4	
			SHC	24.7	28.6	32.5	23.3	27.0	30.7	21.7	25.2	28.6	20.0	23.2	26.4	
		62	TC	31.1	31.1	31.1	28.9	28.9	29.8	26.3	26.3	28.6	23.6	23.6	27.2	
			SHC	22.4	26.6	30.9	21.3	25.6	29.8	20.2	24.4	28.6	18.8	23.0	27.2	
		67	TC	35.2	35.2	35.2	33.0	33.0	33.0	30.4	30.4	30.4	27.5	27.5	27.5	
			SHC	18.7	23.0	27.2	17.8	22.0	26.3	16.7	20.9	25.2	15.5	19.8	24.0	
	72	TC	38.9	38.9	38.9	37.2	37.2	37.2	34.8	34.8	34.8	31.9	31.9	31.9		
		SHC	14.7	19.0	23.3	14.0	18.3	22.6	13.1	17.3	21.6	12.0	16.3	20.5		
	76	TC	—	41.5	41.5	—	40.0	40.0	—	38.0	38.0	—	35.4	35.4		
		SHC	—	15.6	20.5	—	15.1	20.0	—	14.3	19.1	—	13.3	17.8		
	1050 Cfm	EAT (wb)	58	TC	30.5	30.5	34.7	28.8	28.8	32.7	26.9	26.9	30.6	24.8	24.8	28.2
				SHC	26.4	30.5	34.7	24.8	28.8	32.7	23.2	26.9	30.6	21.4	24.8	28.2
62			TC	32.4	32.4	33.9	30.0	30.0	32.7	27.4	27.4	31.3	24.8	24.8	29.3	
			SHC	24.2	29.1	33.9	23.1	27.9	32.7	21.8	26.6	31.3	20.2	24.8	29.3	
67			TC	36.5	36.5	36.5	34.2	34.2	34.2	31.5	31.5	31.5	28.5	28.5	28.5	
			SHC	19.8	24.6	29.4	19.0	23.8	28.7	17.9	22.7	27.6	16.7	21.5	26.4	
72		TC	40.0	40.0	40.0	38.3	38.3	38.3	35.9	35.9	35.9	33.0	33.0	33.0		
		SHC	15.1	19.9	24.7	14.5	19.3	24.1	13.6	18.5	23.3	12.5	17.4	22.3		
76		TC	—	42.5	42.5	—	40.9	40.9	—	39.0	39.0	—	—	—		
		SHC	—	16.3	22.0	—	15.7	21.4	—	14.9	20.2	—	—	—		
1200 Cfm		EAT (wb)	58	TC	32.1	32.1	36.5	30.3	30.3	34.4	28.3	28.3	32.2	26.1	26.1	29.7
				SHC	27.8	32.1	36.5	26.2	30.3	34.4	24.4	28.3	32.2	22.5	26.1	29.7
	62		TC	33.3	33.3	36.6	30.9	30.9	35.3	28.4	28.4	33.5	26.1	26.1	30.9	
			SHC	25.8	31.2	36.6	24.6	29.9	35.3	23.2	28.4	33.5	21.3	26.1	30.9	
	67		TC	37.4	37.4	37.4	35.1	35.1	35.1	32.4	32.4	32.4	29.2	29.2	29.2	
			SHC	20.7	25.9	31.2	20.0	25.4	30.8	18.9	24.4	29.8	17.7	23.1	28.6	
	72	TC	40.7	40.7	40.7	39.0	39.0	39.0	36.7	36.7	36.7	33.8	33.8	33.8		
		SHC	15.4	20.6	25.9	14.8	20.1	25.4	14.0	19.4	24.8	12.9	18.4	23.8		
	76	TC	—	43.2	43.2	—	41.5	41.5	—	39.7	39.7	—	—	—		
		SHC	—	16.7	23.0	—	16.0	22.1	—	15.3	21.2	—	—	—		
	1350 Cfm	EAT (wb)	58	TC	33.5	33.5	38.1	31.6	31.6	35.9	29.5	29.5	33.5	27.2	27.2	30.9
				SHC	28.9	33.5	38.1	27.3	31.6	35.9	25.4	29.5	33.5	23.4	27.2	30.9
62			TC	34.1	34.1	38.9	31.7	31.7	37.5	29.5	29.5	34.9	27.2	27.2	32.2	
			SHC	27.1	33.0	38.9	25.9	31.7	37.5	24.1	29.5	34.9	22.2	27.2	32.2	
67			TC	38.0	38.0	38.0	35.8	35.8	35.8	33.0	33.0	33.0	29.8	29.8	30.6	
			SHC	21.4	27.1	32.8	20.8	26.8	32.7	19.8	25.9	31.9	18.6	24.6	30.6	
72		TC	41.2	41.2	41.2	39.5	39.5	39.5	37.3	37.3	37.3	34.3	34.3	34.3		
		SHC	15.6	21.3	26.9	15.0	20.7	26.5	14.3	20.2	26.1	13.2	19.2	25.3		
76		TC	—	43.7	43.7	—	41.9	41.9	—	40.0	40.0	—	—	—		
		SHC	—	17.0	23.6	—	16.3	22.7	—	15.6	21.9	—	—	—		
1500 Cfm		EAT (wb)	58	TC	34.5	34.5	39.2	32.7	32.7	37.1	30.5	30.5	34.6	28.1	28.1	31.9
				SHC	29.8	34.5	39.2	28.2	32.7	37.1	26.3	30.5	34.6	24.2	28.1	31.9
	62		TC	35.1	35.1	39.1	32.7	32.7	38.7	30.5	30.5	36.1	28.1	28.1	33.3	
			SHC	27.4	33.3	39.1	26.7	32.7	38.7	24.9	30.5	36.1	22.9	28.1	33.3	
	67		TC	38.4	38.4	38.4	36.3	36.3	36.3	33.4	33.4	33.8	30.1	30.1	32.5	
			SHC	22.1	28.2	34.3	21.6	28.0	34.4	20.6	27.2	33.8	19.4	26.0	32.5	
	72	TC	41.6	41.6	41.6	39.8	39.8	39.8	37.7	37.7	37.7	34.7	34.7	34.7		
		SHC	15.7	21.8	27.8	15.1	21.3	27.4	14.4	20.8	27.2	13.5	20.0	26.5		
	76	TC	—	44.0	44.0	—	42.2	42.2	—	40.2	40.2	—	—	—		
		SHC	—	17.2	24.1	—	16.5	23.3	—	15.8	22.5	—	—	—		

### LEGEND

- Do Not Operate
- CFM — Cubic Feet Per Minute (Supply Air)
- EAT (DB) — Entering Air Temperature (dry bulb)
- EAT (WB) — Entering Air Temperature (wet bulb)
- SHC — Sensible Heat Capacity (1000 Btuh) Gross
- TC — Total Capacity (1000 Btuh) Gross

NOTE: See minimum-maximum airflow ratings on page 7.

**RGV/RAV036 — UNIT WITH HOT GAS RE-HEAT SYSTEM IN SUBCOOLING MODE — COOLING CAPACITIES**

TEMP (F) AIR ENTERING CONDENSER (Edb)		AIR ENTERING EVAPORATOR — SCFM/BF								
		900 / 0.01			1200 / 0.02			1500 / 0.04		
		Air Entering Evaporator — Ewb (F)								
		72	67	62	72	67	62	72	67	62
75	TC	29.90	31.00	30.90	29.80	32.50	33.30	33.80	30.90	26.70
	SHC	14.70	19.40	25.50	24.30	19.80	14.90	13.60	17.70	21.20
	kW	2.51	2.49	2.42	2.82	2.74	2.68	3.09	3.01	2.88
85	TC	31.90	27.50	22.70	18.10	23.10	28.40	23.80	18.30	13.20
	SHC	10.70	14.20	17.40	13.00	10.00	6.90	2.60	5.50	8.40
	kW	3.36	3.23	3.06	3.62	3.41	3.24	3.79	3.58	3.39
95	TC	30.30	31.00	30.90	29.80	32.50	33.30	33.80	30.90	26.70
	SHC	14.80	19.40	25.50	24.30	19.80	14.90	13.60	17.70	21.20
	kW	2.53	2.49	2.41	2.82	2.74	2.68	3.09	3.01	2.88
105	TC	31.90	27.50	22.70	18.10	23.10	28.40	23.80	18.30	13.20
	SHC	10.70	14.20	17.40	13.00	10.00	6.90	2.60	5.50	8.40
	kW	3.36	3.23	3.06	3.62	3.41	3.24	3.79	3.58	3.39
115	TC	30.30	31.00	30.90	29.80	32.50	33.30	33.80	30.90	26.70
	SHC	14.80	19.40	25.50	24.30	19.80	14.90	13.60	17.70	21.20
	kW	2.53	2.49	2.41	2.82	2.74	2.68	3.09	3.01	2.88
125	TC	31.90	27.50	22.70	18.10	23.10	28.40	23.80	18.30	13.20
	SHC	10.70	14.20	17.40	0.00	10.00	6.90	2.60	5.50	8.40
	kW	3.36	3.23	3.06	3.62	3.41	3.24	3.79	3.58	3.39

**RGV/RAV036 — UNIT WITH HOT GAS RE-HEAT SYSTEM IN HOT GAS REHEAT MODE — COOLING CAPACITIES**

TEMP (F) AIR ENTERING CONDENSER (Edb)		AIR ENTERING EVAPORATOR — Ewb (F)								
		75 Dry Bulb 62.5 Wet Bulb (50% Relative)			75 Dry Bulb 64 Wet Bulb (56% Relative)			75 Dry Bulb 65.3 Wet Bulb (60% Relative)		
		Air Entering Evaporator — Cfm								
		900	1200	1500	900	1200	1500	900	1200	1500
80	TC	9.81	10.50	10.92	10.83	11.58	12.00	11.78	12.50	12.96
	SHC	1.41	3.09	4.87	0.60	1.98	3.47	-0.05	1.04	2.25
	kW	1.92	1.93	1.94	1.96	1.98	2.00	2.00	2.01	2.02
75	TC	11.71	12.51	13.04	12.67	13.38	13.86	13.44	13.91	14.32
	SHC	3.10	4.87	6.70	2.30	3.67	5.03	1.62	2.51	3.51
	kW	1.87	1.88	1.88	1.89	1.90	1.91	1.91	1.92	1.93
70	TC	13.37	14.10	14.41	13.94	14.53	14.90	14.42	14.95	15.10
	SHC	4.71	6.28	7.52	3.72	4.86	5.88	2.97	4.07	4.47
	kW	1.78	1.80	1.82	1.81	1.83	1.84	1.82	1.82	1.86
60	TC	13.95	14.80	14.62	14.47	15.22	15.53	14.66	14.63	15.46
	SHC	6.20	8.05	7.61	5.67	6.67	7.68	5.03	5.55	6.30
	kW	1.66	1.62	1.70	1.67	1.69	1.68	1.69	1.70	1.71
50	TC	14.26	14.87	15.78	14.65	15.78	16.21	15.01	16.16	16.58
	SHC	5.12	6.39	8.04	3.83	5.37	6.38	2.72	4.09	4.93
	kW	1.98	2.03	1.94	2.01	1.94	1.97	2.03	1.96	1.99
40	TC	14.16	15.50	15.88	15.28	16.24	16.28	15.62	16.60	17.01
	SHC	5.04	6.99	8.14	4.43	5.81	6.44	3.31	4.51	5.34
	kW	2.07	1.95	1.99	1.93	1.91	2.02	1.96	1.94	1.97

**LEGEND**

- EDB** — Entering Dry Bulb
- EWB** — Entering Wet Bulb
- KW** — Compressor Power Input
- SCFM/BF** — Standard Cubic Feet per Minute/Bypass Factor
- SHC** — Sensible Heat Capacity (1000 Btuh) Gross
- TC** — Total Capacity (1000 Btuh) Gross

# Performance data (cont)

## RGV/RAV048 SINGLE STAGE COOLING CAPACITIES

RGV/RAV048				AMBIENT TEMPERATURE (F)												
				85			95			105			115			
				EAT (db)			EAT (db)			EAT (db)			EAT (db)			
				75	80	85	75	80	85	75	80	85	75	80	85	
1200 Cfm	EAT (wb)	58	TC	40.5	40.5	44.8	37.5	37.5	43.0	34.5	34.5	39.6	30.9	30.9	35.7	
			SHC	34.0	39.4	44.8	32.1	37.5	43.0	29.4	34.5	39.6	26.2	30.9	35.7	
		62	TC	43.9	43.9	43.9	40.4	40.4	41.0	36.4	36.4	38.7	31.9	31.9	36.2	
			SHC	31.1	37.1	43.1	29.0	35.0	41.0	26.7	32.7	38.7	24.2	30.2	36.2	
		67	TC	49.3	49.3	49.3	46.1	46.1	46.1	42.3	42.3	42.3	37.8	37.8	37.8	
			SHC	25.7	31.5	37.4	23.9	29.8	35.6	21.8	27.7	33.6	19.4	25.4	31.4	
	72	TC	54.7	54.7	54.7	51.5	51.5	51.5	48.0	48.0	48.0	44.0	44.0	44.0		
		SHC	20.3	25.8	31.2	18.5	24.1	29.7	16.6	22.2	27.9	14.5	20.2	25.9		
	76	TC	—	58.5	58.5	—	55.7	55.7	—	52.3	52.3	—	48.4	48.4		
		SHC	—	21.2	27.8	—	19.4	26.0	—	17.5	24.1	—	15.8	22.4		
	1400 Cfm	EAT (wb)	58	TC	43.0	43.0	49.0	40.1	40.1	45.9	37.0	37.0	42.4	33.3	33.3	38.4
				SHC	37.0	43.0	49.0	34.4	40.1	45.9	31.5	37.0	42.4	28.2	33.3	38.4
62			TC	45.3	45.3	47.5	41.8	41.8	45.3	37.9	37.9	43.0	33.5	33.5	39.7	
			SHC	33.6	40.6	47.5	31.5	38.4	45.3	29.2	36.1	43.0	26.4	33.0	39.7	
67			TC	50.9	50.9	50.9	47.5	47.5	47.5	43.7	43.7	43.7	39.2	39.2	39.2	
			SHC	27.2	34.0	40.7	25.4	32.2	39.0	23.3	30.2	37.1	21.1	28.0	34.9	
72		TC	56.0	56.0	56.0	52.9	52.9	52.9	49.2	49.2	49.2	45.2	45.2	45.2		
		SHC	20.8	27.1	33.5	19.0	25.5	32.1	17.1	23.7	30.3	15.0	21.7	28.4		
76		TC	—	59.8	59.8	—	56.8	56.8	—	53.3	53.3	—	49.3	49.3		
		SHC	—	21.5	29.2	—	20.0	27.7	—	18.3	24.3	—	16.5	22.7		
1600 Cfm		EAT (wb)	58	TC	45.2	45.2	51.5	42.2	42.2	48.3	39.0	39.0	44.7	35.2	35.2	40.6
				SHC	38.8	45.2	51.5	36.2	42.2	48.3	33.2	39.0	44.7	29.9	35.2	40.6
	62		TC	46.4	46.4	51.4	42.8	42.8	49.0	39.2	39.2	46.0	35.3	35.3	42.4	
			SHC	35.8	43.6	51.4	33.6	41.3	49.0	31.0	38.5	46.0	28.1	35.3	42.4	
	67		TC	51.9	51.9	51.9	48.4	48.4	48.4	44.6	44.6	44.6	40.0	40.0	40.0	
			SHC	28.5	36.1	43.6	26.6	34.3	42.0	24.7	32.5	40.2	22.4	30.2	38.0	
	72	TC	56.8	56.8	56.8	53.7	53.7	53.7	50.0	50.0	50.0	45.8	45.8	45.8		
		SHC	21.0	28.2	35.3	19.3	26.7	34.0	17.4	24.9	32.4	15.4	22.9	30.5		
	76	TC	—	60.4	60.4	—	57.4	57.4	—	53.9	53.9	—	—	—		
		SHC	—	22.0	27.8	—	20.5	27.1	—	18.8	25.8	—	—	—		
	1800 Cfm	EAT (wb)	58	TC	46.8	46.8	53.4	43.9	43.9	50.2	40.5	40.5	46.5	36.8	36.8	42.4
				SHC	40.2	46.8	53.4	37.6	43.9	50.2	34.6	40.5	46.5	31.2	36.8	42.4
62			TC	47.3	47.3	54.6	45.5	45.5	48.6	41.0	41.0	47.7	36.8	36.8	44.3	
			SHC	37.6	46.1	54.6	33.9	41.3	48.6	32.2	39.9	47.7	29.3	36.8	44.3	
67			TC	52.5	52.5	52.5	49.0	49.0	49.0	45.1	45.1	45.1	40.5	40.5	40.9	
			SHC	29.5	37.8	46.2	27.7	36.2	44.7	25.8	34.4	43.0	23.5	32.2	40.9	
72		TC	57.3	57.3	57.3	54.1	54.1	54.1	50.4	50.4	50.4	46.2	46.2	46.2		
		SHC	21.2	29.0	36.9	19.5	27.6	35.7	17.6	25.8	34.1	15.5	23.9	32.3		
76		TC	—	60.7	60.7	—	57.8	57.8	—	54.2	54.2	—	—	—		
		SHC	—	22.2	29.5	—	20.7	28.2	—	19.0	26.9	—	—	—		
2000 Cfm		EAT (wb)	58	TC	48.0	48.0	54.8	45.1	45.1	51.6	41.8	41.8	47.9	38.0	38.0	43.7
				SHC	41.3	48.0	54.8	38.6	45.1	51.6	35.6	41.8	47.9	32.2	38.0	43.7
	62		TC	48.5	48.5	56.1	46.6	46.6	49.4	41.8	41.8	50.0	38.0	38.0	45.7	
			SHC	38.6	47.3	56.1	34.5	42.0	49.4	33.5	41.8	50.0	30.2	38.0	45.7	
	67		TC	52.7	52.7	52.7	49.2	49.2	49.2	45.3	45.3	45.6	40.7	40.7	43.7	
			SHC	30.3	39.4	48.5	28.6	37.9	47.2	26.7	36.1	45.6	24.5	34.1	43.7	
	72	TC	57.5	57.5	57.5	54.3	54.3	54.3	50.6	50.6	50.6	46.3	46.3	46.3		
		SHC	21.1	29.6	38.2	19.4	28.3	37.1	17.6	26.6	35.6	15.6	24.8	33.9		
	76	TC	—	60.7	60.7	—	57.8	57.8	—	—	—	—	—	—		
		SHC	—	22.3	30.4	—	20.8	29.1	—	—	—	—	—	—		

### LEGEND

- Do Not Operate
- CFM — Cubic Feet Per Minute (Supply Air)
- EAT (DB) — Entering Air Temperature (dry bulb)
- EAT (WB) — Entering Air Temperature (wet bulb)
- SHC — Sensible Heat Capacity (1000 Btuh) Gross
- TC — Total Capacity (1000 Btuh) Gross

NOTE: See minimum-maximum airflow ratings on page 7.

**RGV/RAV048 — UNIT WITH HOT GAS RE-HEAT SYSTEM IN SUBCOOLING MODE — COOLING CAPACITIES**

TEMP (F) AIR ENTERING CONDENSER (Edb)		AIR ENTERING EVAPORATOR — SCFM/BF								
		1200 / 0.04			1600 / 0.07			2000 / 0.10		
		Air Entering Evaporator — Ewb (F)								
		72	67	62	72	67	62	72	67	62
75	TC	49.7	44.9	40.6	52.9	47.8	43.5	54.8	49.8	0.0
	SHC	20.8	26.2	31.6	24.0	30.9	37.9	26.8	35.2	0.0
	kW	2.50	2.47	2.44	2.46	2.48	2.51	2.53	2.50	0.00
85	TC	46.5	42.0	37.9	49.1	44.7	40.6	51.2	46.5	42.6
	SHC	17.8	23.5	29.2	20.5	28.0	35.2	23.5	32.1	40.5
	kW	2.81	2.78	2.76	2.78	2.80	2.82	2.84	2.81	2.79
95	TC	43.1	38.9	35.1	45.8	41.5	37.6	47.5	43.1	39.4
	SHC	14.6	20.6	26.5	17.5	25.0	32.4	20.1	28.9	37.5
	kW	3.16	3.14	3.12	3.13	3.15	3.18	3.19	3.16	3.14
105	TC	39.3	35.3	32.0	41.8	37.7	34.2	43.4	39.1	35.9
	SHC	11.1	17.3	23.7	13.8	21.5	29.3	16.3	25.3	34.3
	kW	3.56	3.54	3.52	3.54	3.55	3.58	3.59	3.56	3.55
115	TC	35.3	31.8	28.6	37.4	33.7	30.5	39.1	35.3	32.2
	SHC	7.5	14.1	20.6	9.7	17.8	25.9	12.3	21.8	30.8
	kW	4.02	4.01	4.00	4.00	4.01	4.03	4.04	4.03	4.01
125	TC	31.2	27.9	24.9	33.2	29.8	26.8	34.5	31.0	28.3
	SHC	3.7	10.5	17.3	5.9	14.3	22.5	8.1	17.9	27.1
	kW	4.54	4.53	4.53	4.53	4.54	4.54	4.55	4.54	4.54

**RGV/RAV048 — UNIT WITH HOT GAS RE-HEAT SYSTEM IN HOT GAS REHEAT MODE — COOLING CAPACITIES**

TEMP (F) AIR ENTERING CONDENSER (Edb)		AIR ENTERING EVAPORATOR — Ewb (F)								
		75 Dry Bulb 62.5 Wet Bulb (50% Relative)			75 Dry Bulb 64 Wet Bulb (56% Relative)			75 Dry Bulb 65.3 Wet Bulb (60% Relative)		
		Air Entering Evaporator — Cfm								
		1200	1600	2000	1200	1600	2000	1200	1600	2000
80	TC	10.55	10.36	10.16	11.65	11.44	11.20	12.56	12.35	12.04
	SHC	-1.90	-1.24	-0.52	-3.80	-3.40	-2.95	-5.39	-5.19	-4.97
	kW	3.15	3.16	3.16	3.19	3.20	3.20	3.22	3.23	3.23
75	TC	12.91	12.76	12.57	13.89	13.76	13.47	14.64	14.56	14.25
	SHC	0.35	0.98	1.63	-1.54	-1.09	-0.76	-3.12	-2.80	-2.65
	kW	3.04	3.05	3.06	3.07	3.08	3.09	3.10	3.12	3.12
70	TC	15.12	14.94	14.82	15.98	15.88	15.60	16.69	16.50	16.13
	SHC	2.51	3.04	3.60	0.68	1.11	1.36	-0.78	-0.55	-0.50
	kW	2.92	2.93	2.95	2.96	2.97	2.98	2.98	2.99	3.00
60	TC	18.97	18.79	18.53	19.24	19.18	18.82	19.83	19.58	21.59
	SHC	6.49	6.91	7.10	4.77	5.17	5.26	3.72	3.89	4.75
	kW	3.17	3.23	3.15	3.21	3.26	3.18	3.23	3.12	3.10
50	TC	17.53	13.35	13.30	13.45	13.58	13.53	13.67	13.79	13.74
	SHC	9.21	8.03	7.71	7.82	7.54	7.16	7.44	7.10	6.68
	kW	3.01	3.07	3.11	3.04	3.10	3.15	3.07	3.14	3.18
40	TC	17.53	13.35	13.30	13.45	13.58	13.53	13.67	13.79	13.74
	SHC	9.21	8.03	7.71	7.82	7.54	7.16	7.44	7.10	6.68
	kW	3.39	3.32	3.24	3.14	3.23	3.15	3.18	3.27	3.08

**LEGEND**

- EDB** — Entering Dry Bulb
- EWB** — Entering Wet Bulb
- KW** — Compressor Power Input
- SCFM/BF** — Standard Cubic Feet per Minute/Bypass Factor
- SHC** — Sensible Heat Capacity (1000 Btuh) Gross
- TC** — Total Capacity (1000 Btuh) Gross

# Performance data (cont)

## RGV/RAV060 SINGLE STAGE COOLING CAPACITIES

RGV/RAV060				AMBIENT TEMPERATURE (F)												
				85			95			105			115			
				EAT (db)			EAT (db)			EAT (db)			EAT (db)			
				75	80	85	75	80	85	75	80	85	75	80	85	
1500 Cfm	EAT (wb)	58	TC	52.2	52.2	58.7	49.3	49.3	55.4	46.0	46.0	51.7	42.5	42.5	47.7	
			SHC	45.7	52.2	58.7	43.2	49.3	55.4	40.3	46.0	51.7	37.2	42.5	47.7	
		62	TC	55.2	55.2	56.6	51.3	51.3	54.6	47.1	47.1	52.4	42.6	42.6	49.7	
			SHC	41.9	49.2	56.6	40.0	47.3	54.6	37.9	45.2	52.4	35.5	42.6	49.7	
		67	TC	61.0	61.0	61.0	57.5	57.5	57.5	53.2	53.2	53.2	48.4	48.4	48.4	
			SHC	34.7	41.9	49.1	33.3	40.6	48.0	31.5	38.9	46.2	29.5	36.8	44.2	
	72	TC	64.4	64.4	64.4	62.9	62.9	62.9	59.4	59.4	59.4	55.1	55.1	55.1		
		SHC	26.4	33.4	40.5	25.8	33.1	40.3	24.5	31.8	39.1	22.8	30.2	37.6		
	76	TC	—	66.0	66.0	—	65.1	65.1	—	63.0	63.0	—	59.5	59.5		
		SHC	—	26.9	35.1	—	26.5	34.8	—	25.8	34.0	—	24.4	32.4		
	1750 Cfm	EAT (wb)	58	TC	54.8	54.8	61.7	51.6	51.6	58.1	48.2	48.2	54.3	44.5	44.5	50.1
				SHC	47.9	54.8	61.7	45.1	51.6	58.1	42.1	48.2	54.3	38.9	44.5	50.1
62			TC	56.5	56.5	60.9	52.7	52.7	59.0	48.4	48.4	56.5	44.6	44.6	52.1	
			SHC	44.3	52.6	60.9	42.4	50.7	59.0	40.2	48.4	56.5	37.0	44.6	52.1	
67			TC	62.0	62.0	62.0	58.7	58.7	58.7	54.4	54.4	54.4	49.4	49.4	49.4	
			SHC	35.7	43.7	51.7	34.6	42.9	51.2	32.9	41.3	49.7	30.9	39.3	47.8	
72		TC	64.6	64.6	64.6	63.4	63.4	63.4	60.3	60.3	60.3	56.1	56.1	56.1		
		SHC	26.2	33.8	41.5	25.8	33.8	41.8	24.6	32.9	41.1	23.1	31.4	39.8		
76		TC	—	65.9	65.9	—	64.8	64.8	—	63.3	63.3	—	59.9	59.9		
		SHC	—	27.2	36.8	—	26.7	36.3	—	26.0	35.1	—	24.7	33.5		
2000 Cfm		EAT (wb)	58	TC	56.6	56.6	63.8	53.5	53.5	60.3	49.9	49.9	56.3	46.1	46.1	52.0
				SHC	49.4	56.6	63.8	46.7	53.5	60.3	43.6	49.9	56.3	40.2	46.1	52.0
	62		TC	57.5	57.5	64.5	53.7	53.7	62.9	50.0	50.0	58.5	46.1	46.1	54.0	
			SHC	46.2	55.3	64.5	44.5	53.7	62.9	41.4	50.0	58.5	38.2	46.1	54.0	
	67		TC	62.1	62.1	62.1	59.3	59.3	59.3	55.0	55.0	55.0	50.0	50.0	51.0	
			SHC	36.0	44.6	53.3	35.5	44.7	53.9	34.0	43.4	52.8	32.1	41.6	51.0	
	72	TC	64.3	64.3	64.3	63.4	63.4	63.4	60.6	60.6	60.6	56.5	56.5	56.5		
		SHC	25.7	34.0	42.2	25.4	34.1	42.7	24.5	33.6	42.6	23.1	32.3	41.6		
	76	TC	—	65.6	65.6	—	64.1	64.1	—	63.1	63.1	—	59.9	59.9		
		SHC	—	27.0	37.5	—	26.4	36.5	—	25.8	35.6	—	24.6	34.3		
	2250 Cfm	EAT (wb)	58	TC	57.7	57.7	65.2	54.7	54.7	61.8	51.2	51.2	57.8	47.2	47.2	53.3
				SHC	50.2	57.7	65.2	47.6	54.7	61.8	44.5	51.2	57.8	41.0	47.2	53.3
62			TC	57.9	57.9	67.9	54.8	54.8	64.3	51.2	51.2	60.1	47.2	47.2	55.4	
			SHC	47.9	57.9	67.9	45.3	54.8	64.3	42.3	51.2	60.1	39.0	47.2	55.4	
67			TC	61.7	61.7	61.7	59.5	59.5	59.5	55.2	55.2	55.5	50.2	50.2	53.9	
			SHC	36.0	45.1	54.3	36.1	46.2	56.2	34.8	45.1	55.5	33.0	43.5	53.9	
72		TC	63.9	63.9	63.9	62.9	62.9	62.9	60.5	60.5	60.5	56.5	56.5	56.5		
		SHC	25.1	33.8	42.5	24.9	34.0	43.2	24.2	33.9	43.6	22.8	32.9	43.0		
76		TC	—	65.0	65.0	—	63.5	63.5	—	62.6	62.6	—	59.5	59.5		
		SHC	—	26.5	37.3	—	25.9	36.4	—	25.4	35.8	—	24.4	34.6		
2500 Cfm		EAT (wb)	58	TC	58.2	58.2	65.9	55.4	55.4	62.7	51.9	51.9	58.8	47.9	47.9	54.3
				SHC	50.6	58.2	65.9	48.1	55.4	62.7	45.1	51.9	58.8	41.6	47.9	54.3
	62		TC	58.2	58.2	68.5	56.4	56.4	59.5	51.9	51.9	61.1	47.9	47.9	56.4	
			SHC	48.0	58.2	68.5	42.8	51.1	59.5	42.8	51.9	61.1	39.4	47.9	56.4	
	67		TC	61.1	61.1	61.1	59.2	59.2	59.2	55.1	55.1	57.7	50.1	50.1	56.3	
			SHC	35.8	45.5	55.2	36.4	47.2	57.9	35.3	46.5	57.7	33.6	44.9	56.3	
	72	TC	63.1	63.1	63.1	62.0	62.0	62.0	60.0	60.0	60.0	56.1	56.1	56.1		
		SHC	24.3	33.4	42.5	24.0	33.6	43.2	23.5	33.9	44.3	22.3	33.1	43.9		
	76	TC	—	64.1	64.1	—	62.7	62.7	—	61.8	61.8	—	58.8	58.8		
		SHC	—	25.8	36.9	—	25.2	36.1	—	24.8	35.7	—	23.8	34.7		

### LEGEND

- Do Not Operate
- CFM — Cubic Feet Per Minute (Supply Air)
- EAT (DB) — Entering Air Temperature (dry bulb)
- EAT (WB) — Entering Air Temperature (wet bulb)
- SHC — Sensible Heat Capacity (1000 Btuh) Gross
- TC — Total Capacity (1000 Btuh) Gross

NOTE: See minimum-maximum airflow ratings on page 7.

**RGV/RAV060 — UNIT WITH HOT GAS RE-HEAT SYSTEM IN SUBCOOLING MODE — COOLING CAPACITIES**

TEMP (F) AIR ENTERING CONDENSER (Edb)		AIR ENTERING EVAPORATOR — SCFM/BF								
		1500 / 0.01			2000 / 0.02			2500 / 0.03		
		Air Entering Evaporator — Ewb (F)								
		72	67	62	72	67	62	72	67	62
75	TC	65.6	59.0	53.7	69.6	63.1	57.4	72.0	65.6	60.4
	SHC	25.3	33.5	42.2	29.9	40.9	51.6	34.3	47.6	60.0
	kW	3.11	3.06	3.03	3.05	3.09	3.16	3.16	3.11	3.07
85	TC	61.1	55.4	50.2	65.0	58.9	53.7	66.8	61.0	56.4
	SHC	21.1	30.0	38.8	25.6	36.9	48.0	29.3	43.3	56.0
	kW	3.47	3.43	3.39	3.42	3.46	3.51	3.52	3.48	3.44
95	TC	56.7	51.2	46.4	60.1	54.5	49.6	62.2	56.5	52.1
	SHC	16.9	26.1	35.2	21.0	32.7	44.2	25.0	39.1	52.1
	kW	3.89	3.85	3.80	3.83	3.88	3.93	3.95	3.90	3.86
105	TC	51.8	46.6	42.0	54.3	49.0	44.4	56.9	51.1	46.9
	SHC	12.3	21.7	31.1	15.5	27.5	39.3	20.0	34.0	46.9
	kW	4.36	4.31	4.26	4.29	4.33	4.38	4.42	4.36	4.32
115	TC	46.5	41.9	37.8	49.1	44.3	40.2	50.8	46.2	42.5
	SHC	7.3	17.3	27.2	10.7	23.2	35.4	14.4	29.4	42.5
	kW	4.88	4.83	4.78	4.81	4.86	4.91	4.93	4.88	4.84
125	TC	40.8	36.7	33.1	43.1	38.9	35.1	44.9	40.5	37.3
	SHC	2.0	12.5	22.8	5.2	18.2	30.5	8.9	24.2	37.3
	kW	5.44	5.39	5.35	5.37	5.42	5.47	5.49	5.44	5.40

**RGV/RAV060 — UNIT WITH HOT GAS RE-HEAT SYSTEM IN HOT GAS REHEAT MODE — COOLING CAPACITIES**

TEMP (F) AIR ENTERING CONDENSER (Edb)		AIR ENTERING EVAPORATOR — Ewb (F)								
		75 Dry Bulb 62.5 Wet Bulb (50% Relative)			75 Dry Bulb 64 Wet Bulb (56% Relative)			75 Dry Bulb 65.3 Wet Bulb (60% Relative)		
		Air Entering Evaporator — Cfm								
		1500	2000	2500	1500	2000	2500	1500	2000	2500
80	TC	13.19	12.95	12.70	14.56	14.30	14.00	15.70	15.44	15.05
	SHC	-2.38	-1.55	-0.65	-4.75	-4.25	-3.69	-6.74	-6.49	-6.21
	kW	3.15	3.16	3.16	3.19	3.20	3.20	3.22	3.23	3.23
75	TC	16.14	15.95	15.71	17.36	17.20	16.84	18.30	18.20	17.81
	SHC	0.44	1.23	2.03	-1.92	-1.36	-0.96	-3.90	-3.50	-3.31
	kW	3.04	3.05	3.06	3.07	3.08	3.09	3.10	3.12	3.12
70	TC	18.90	18.68	18.52	19.97	19.85	19.50	20.86	20.62	20.17
	SHC	3.13	3.80	4.51	0.85	1.39	1.70	-0.97	-0.69	-0.63
	kW	2.92	2.93	2.95	2.96	2.97	2.98	2.98	2.99	3.00
60	TC	23.71	23.48	23.16	24.05	23.98	23.52	24.79	24.47	26.99
	SHC	8.11	8.63	8.88	5.97	6.46	6.58	4.65	4.87	5.94
	kW	3.17	3.23	3.15	3.21	3.26	3.18	3.23	3.12	3.10
50	TC	21.91	16.69	16.62	16.81	16.98	16.92	17.08	17.24	17.17
	SHC	11.51	10.04	9.64	9.77	9.43	8.95	9.30	8.88	8.35
	kW	3.01	3.07	3.11	3.04	3.10	3.15	3.07	3.14	3.18
40	TC	21.91	16.69	16.62	16.81	16.98	16.92	17.08	17.24	17.17
	SHC	11.51	10.04	9.64	9.77	9.43	8.95	9.30	8.88	8.35
	kW	3.39	3.32	3.24	3.14	3.23	3.15	3.18	3.27	3.08

**LEGEND**

- EDB** — Entering Dry Bulb
- EWB** — Entering Wet Bulb
- KW** — Compressor Power Input
- SCFM/BF** — Standard Cubic Feet per Minute/Bypass Factor
- SHC** — Sensible Heat Capacity (1000 Btuh) Gross
- TC** — Total Capacity (1000 Btuh) Gross

# Performance data (cont)

## RGV/RAV072 HIGH STAGE COOLING CAPACITIES

RGV/RAV072				AMBIENT TEMPERATURE (F)												
				85			95			105			115			
				EAT (db)			EAT (db)			EAT (db)			EAT (db)			
				75	80	85	75	80	85	75	80	85	75	80	85	
1800 Cfm	EAT (wb)	58	TC	63.8	63.8	72.2	61.1	61.1	69.1	58.1	58.1	65.8	54.9	54.9	62.3	
			SHC	55.5	63.8	72.2	53.0	61.1	69.1	50.4	58.1	65.8	47.6	54.9	62.3	
		62	TC	67.2	67.2	68.3	63.7	63.7	66.4	60.0	60.0	64.4	56.2	56.2	62.3	
			SHC	49.9	59.1	68.3	48.1	57.3	66.4	46.1	55.3	64.4	44.1	53.2	62.3	
		67	TC	73.2	73.2	73.2	69.5	69.5	69.5	65.5	65.5	65.5	61.4	61.4	61.4	
			SHC	40.8	50.0	59.2	39.0	48.2	57.4	37.1	46.3	55.6	35.2	44.4	53.6	
	72	TC	79.7	79.7	79.7	75.7	75.7	75.7	71.5	71.5	71.5	67.1	67.1	67.1		
		SHC	31.4	40.7	50.0	29.7	39.0	48.3	27.9	37.2	46.4	26.1	35.3	44.5		
	76	TC	—	85.3	85.3	—	81.0	81.0	—	76.6	76.6	—	72.0	72.0		
		SHC	—	33.3	43.1	—	31.6	41.3	—	29.8	39.5	—	28	37.6		
	2100 Cfm	EAT (wb)	58	TC	67.1	67.1	75.9	64.1	64.1	72.5	60.9	60.9	69.0	57.6	57.6	65.2
				SHC	58.3	67.1	75.9	55.7	64.1	72.5	52.8	60.9	69.0	49.9	57.6	65.2
62			TC	69.0	69.0	74.7	65.4	65.4	72.6	61.6	61.6	70.4	57.7	57.7	68	
			SHC	53.6	64.1	74.7	51.7	62.2	72.6	49.6	60.0	70.4	47.4	57.7	68	
67			TC	75.0	75.0	75.0	71.2	71.2	71.2	67.0	67.0	67.0	62.7	62.7	62.7	
			SHC	43.2	53.8	64.4	41.4	52.0	62.6	39.5	50.1	60.7	37.6	48.2	58.7	
72		TC	81.6	81.6	81.6	77.5	77.5	77.5	73.1	73.1	73.1	68.5	68.5	68.5		
		SHC	32.5	43.2	53.8	30.7	41.4	52.0	28.9	39.5	50.1	27.1	37.6	48.2		
76		TC	—	87.2	87.2	—	82.8	82.8	—	78.2	78.2	—	73.5	73.5		
		SHC	—	34.6	45.7	—	32.9	43.9	—	31.1	42.0	—	29.2	40.1		
2400 Cfm		EAT (wb)	58	TC	69.7	69.7	78.8	66.6	66.6	75.3	63.2	63.2	71.6	59.7	59.7	67.6
				SHC	60.6	69.7	78.8	57.8	66.6	75.3	54.9	63.2	71.6	51.7	59.7	67.6
	62		TC	70.5	70.5	80.4	66.9	66.9	78.0	63.3	63.3	74.4	59.7	59.7	70.3	
			SHC	57.0	68.7	80.4	54.9	66.5	78.0	52.1	63.3	74.4	49.1	59.7	70.3	
	67		TC	76.4	76.4	76.4	72.4	72.4	72.4	68.2	68.2	68.2	63.8	63.8	63.8	
			SHC	45.5	57.5	69.4	43.7	55.6	67.5	41.8	53.7	65.6	39.8	51.7	63.6	
	72	TC	83.1	83.1	83.1	78.8	78.8	78.8	74.2	74.2	74.2	69.6	69.6	69.6		
		SHC	33.5	45.5	57.4	31.7	43.6	55.6	29.8	41.8	53.7	28.0	39.9	51.7		
	76	TC	—	88.8	88.8	—	84.2	84.2	—	79.5	79.5	—	74.6	74.6		
		SHC	—	35.9	48.2	—	34.1	46.4	—	32.3	44.5	—	30.4	42.5		
	2700 Cfm	EAT (wb)	58	TC	71.9	71.9	81.3	68.7	68.7	77.7	65.1	65.1	73.7	61.5	61.5	69.7
				SHC	62.5	71.9	81.3	59.6	68.7	77.7	56.5	65.1	73.7	53.3	61.5	69.7
62			TC	72.0	72.0	84.5	68.7	68.7	80.7	65.2	65.2	76.6	61.5	61.5	72.4	
			SHC	59.5	72.0	84.5	56.7	68.7	80.7	53.7	65.2	76.6	50.6	61.5	72.4	
67			TC	77.5	77.5	77.5	73.4	73.4	73.4	69.0	69.0	70.3	64.5	64.5	68.3	
			SHC	47.7	61.0	74.2	45.9	59.1	72.3	43.9	57.1	70.3	41.9	55.1	68.3	
72		TC	84.2	84.2	84.2	79.8	79.8	79.8	75.2	75.2	75.2	70.4	70.4	70.4		
		SHC	34.4	47.6	60.9	32.6	45.8	59.0	30.7	43.9	57.1	28.8	42.0	55.1		
76		TC	—	90.0	90.0	—	85.3	85.3	—	80.5	80.5	—	75.5	75.5		
		SHC	—	37.0	50.6	—	35.2	48.7	—	33.4	46.8	—	31.5	44.8		
3000 Cfm		EAT (wb)	58	TC	73.8	73.8	83.4	70.4	70.4	79.6	66.8	66.8	75.6	63.0	63.0	71.3
				SHC	64.2	73.8	83.4	61.2	70.4	79.6	58.0	66.8	75.6	54.6	63.0	71.3
	62		TC	73.8	73.8	86.6	70.4	70.4	82.7	66.8	66.8	78.5	63.0	63.0	74.1	
			SHC	61.0	73.8	86.6	58.2	70.4	82.7	55.1	66.8	78.5	51.9	63.0	74.1	
	67		TC	78.4	78.4	78.9	74.2	74.2	76.9	69.7	69.7	74.8	65.2	65.2	72.6	
			SHC	49.8	64.3	78.9	47.9	62.4	76.9	46.0	60.4	74.8	43.9	58.3	72.6	
	72	TC	85.1	85.1	85.1	80.6	80.6	80.6	75.9	75.9	75.9	71.1	71.1	71.1		
		SHC	35.2	49.7	64.3	33.4	47.9	62.4	31.5	46.0	60.4	29.7	44.0	58.4		
	76	TC	—	91.0	91.0	—	86.2	86.2	—	81.3	81.3	—	76.3	76.3		
		SHC	—	38.1	52.9	—	36.3	51.0	—	34.5	49.0	—	32.5	47.0		

### LEGEND

- Do Not Operate
- CFM — Cubic Feet Per Minute (Supply Air)
- EAT (DB) — Entering Air Temperature (dry bulb)
- EAT (WB) — Entering Air Temperature (wet bulb)
- SHC — Sensible Heat Capacity (1000 Btuh) Gross
- TC — Total Capacity (1000 Btuh) Gross

NOTE: See minimum-maximum airflow ratings on page 7.

### RGV/RAV072 LOW STAGE COOLING CAPACITIES

RGV/RAV072			AMBIENT TEMPERATURE (F)													
			85			95			105			115				
			EAT (db)			EAT (db)			EAT (db)			EAT (db)				
			75	80	85	75	80	85	75	80	85	75	80	85		
1200 Cfm	EAT (wb)	58	TC	44.2	44.2	50.4	41.6	41.6	47.5	38.8	38.8	44.4	35.7	35.7	41.0	
			SHC	38.0	44.2	50.4	35.7	41.6	47.5	33.1	38.8	44.4	30.3	35.7	41.0	
		62	TC	47.6	47.6	47.6	44.3	44.3	45.1	40.8	40.8	43.0	37.0	37.0	40.7	
			SHC	34.0	40.5	47.0	32.0	38.5	45.1	29.9	36.5	43.0	27.7	34.2	40.7	
		67	TC	53.1	53.1	53.1	49.7	49.7	49.7	45.9	45.9	45.9	41.9	41.9	41.9	
			SHC	28.1	34.7	41.2	26.2	32.7	39.2	24.1	30.6	37.2	21.9	28.5	35.0	
	72	TC	59.0	59.0	59.0	55.4	55.4	55.4	51.5	51.5	51.5	47.2	47.2	47.2		
		SHC	22.1	28.6	35.2	20.2	26.7	33.3	18.1	24.7	31.2	16.0	22.6	29.1		
	76	TC	—	64.2	64.2	—	60.4	60.4	—	56.3	56.3	—	51.8	51.8		
		SHC	—	23.7	30.3	—	21.8	28.4	—	19.8	26.4	—	17.8	24.4		
	1400 Cfm	EAT (wb)	58	TC	47.4	47.4	53.9	44.6	44.6	50.9	41.6	41.6	47.6	38.3	38.3	43.9
				SHC	40.8	47.4	53.9	38.3	44.6	50.9	35.6	41.6	47.6	32.6	38.3	43.9
62			TC	49.5	49.5	52.3	46.1	46.1	50.3	42.4	42.4	48.1	38.5	38.5	45.7	
			SHC	37.2	44.8	52.3	35.2	42.7	50.3	33.0	40.6	48.1	30.7	38.2	45.7	
67			TC	55.0	55.0	55.0	51.5	51.5	51.5	47.5	47.5	47.5	43.3	43.3	43.3	
			SHC	30.2	37.8	45.4	28.3	35.8	43.4	26.1	33.7	41.3	23.9	31.5	39.1	
72		TC	61.1	61.1	61.1	57.3	57.3	57.3	53.1	53.1	53.1	48.7	48.7	48.7		
		SHC	23.1	30.8	38.4	21.2	28.8	36.4	19.1	26.7	34.3	16.9	24.6	32.2		
76		TC	—	66.4	66.4	—	62.4	62.4	—	58.1	58.1	—	53.4	53.4		
		SHC	—	25.0	32.7	—	23.1	30.8	—	21.1	28.8	—	18.9	26.6		
1600 Cfm		EAT (wb)	58	TC	50.0	50.0	56.8	47.1	47.1	53.6	43.9	43.9	50.1	40.4	40.4	46.3
				SHC	43.1	50.0	56.8	40.5	47.1	53.6	37.6	43.9	50.1	34.5	40.4	46.3
	62		TC	51.0	51.0	57.3	47.5	47.5	55.2	43.9	43.9	52.3	40.5	40.5	48.4	
			SHC	40.2	48.8	57.3	38.1	46.6	55.2	35.6	43.9	52.3	32.6	40.5	48.4	
	67		TC	56.5	56.5	56.5	52.8	52.8	52.8	48.7	48.7	48.7	44.3	44.3	44.3	
			SHC	32.2	40.9	49.5	30.2	38.8	47.5	28.1	36.7	45.3	25.8	34.5	43.1	
	72	TC	62.6	62.6	62.6	58.7	58.7	58.7	54.4	54.4	54.4	49.8	49.8	49.8		
		SHC	24.1	32.7	41.4	22.1	30.7	39.4	20.0	28.6	37.3	17.8	26.5	35.1		
	76	TC	—	68.0	68.0	—	63.9	63.9	—	59.5	59.5	—	54.7	54.7		
		SHC	—	26.2	35	—	24.2	33.0	—	22.2	30.9	—	20.0	28.8		
	1800 Cfm	EAT (wb)	58	TC	52.2	52.2	59.3	49.2	49.2	56.0	45.8	45.8	52.3	42.2	42.2	48.4
				SHC	45.1	52.2	59.3	42.4	49.2	56.0	39.3	45.8	52.3	36.1	42.2	48.4
62			TC	52.3	52.3	61.8	49.2	49.2	58.3	45.9	45.9	54.5	42.3	42.3	50.4	
			SHC	42.8	52.3	61.8	40.2	49.2	58.3	37.2	45.9	54.5	34.1	42.3	50.4	
67			TC	57.6	57.6	57.6	53.8	53.8	53.8	49.6	49.6	49.6	45.2	45.2	47.0	
			SHC	34.1	43.8	53.5	32.1	41.8	51.4	29.9	39.6	49.3	27.6	37.3	47.0	
72		TC	63.8	63.8	63.8	59.8	59.8	59.8	55.4	55.4	55.4	50.7	50.7	50.7		
		SHC	24.9	34.6	44.4	22.9	32.6	42.3	20.8	30.5	40.2	18.6	28.3	38.0		
76		TC	—	69.4	69.4	—	65.2	65.2	—	60.6	60.6	—	—	—		
		SHC	—	27.3	37.1	—	25.3	35.1	—	23.2	33.0	—	—	—		
2000 Cfm		EAT (wb)	58	TC	54.1	54.1	61.5	51.0	51.0	58.0	47.5	47.5	54.2	43.8	43.8	50.1
				SHC	46.8	54.1	61.5	43.9	51.0	58.0	40.8	47.5	54.2	37.4	43.8	50.1
	62		TC	54.2	54.2	64.0	51.0	51.0	60.4	47.6	47.6	56.5	43.8	43.8	52.2	
			SHC	44.4	54.2	64.0	41.7	51.0	60.4	38.6	47.6	56.5	35.4	43.8	52.2	
	67		TC	58.6	58.6	58.6	54.7	54.7	55.3	50.4	50.4	53.0	45.9	45.9	50.7	
			SHC	35.9	46.6	57.3	33.8	44.6	55.3	31.7	42.3	53.0	29.4	40.0	50.7	
	72	TC	64.8	64.8	64.8	60.7	60.7	60.7	56.1	56.1	56.1	51.4	51.4	51.4		
		SHC	25.7	36.5	47.2	23.7	34.4	45.2	21.5	32.3	43.0	19.3	30.0	40.8		
	76	TC	—	70.5	70.5	—	66.2	66.2	—	—	—	—	—	—		
		SHC	—	28.3	39.2	—	26.3	37.1	—	—	—	—	—	—		

**LEGEND**

- Do Not Operate
- CFM** — Cubic Feet Per Minute (Supply Air)
- EAT (DB)** — Entering Air Temperature (dry bulb)
- EAT (WB)** — Entering Air Temperature (wet bulb)
- SHC** — Sensible Heat Capacity (1000 Btuh) Gross
- TC** — Total Capacity (1000 Btuh) Gross

NOTE: See minimum-maximum airflow ratings on page 7.

# Performance data (cont)

## RGV/RAV072 — UNIT WITH HOT GAS RE-HEAT SYSTEM IN SUBCOOLING MODE — COOLING CAPACITIES

TEMP (F) AIR ENTERING CONDENSER (Edb)		AIR ENTERING EVAPORATOR — SCFM/BF								
		1800 / 0.06			2400 / 0.08			3000 / 0.10		
		Air Entering Evaporator — Ewb (F)								
		72	67	62	72	67	62	72	67	62
75	TC	73.7	66.6	60.2	78.4	71.0	64.4	81.3	73.7	67.4
	SHC	32.8	40.5	48.3	37.8	47.8	57.7	42.1	54.3	65.7
	kW	4.05	4.01	3.97	4.00	4.04	4.08	4.09	4.05	4.02
85	TC	69.5	62.8	56.8	73.8	67.0	60.7	76.8	69.6	63.6
	SHC	28.8	36.9	45.0	33.4	43.9	54.2	37.7	50.4	62.0
	kW	4.46	4.43	4.39	4.42	4.45	4.48	4.51	4.47	4.43
95	TC	65.1	58.8	53.0	69.3	62.7	56.8	71.9	65.1	59.5
	SHC	24.7	33.1	41.5	29.1	39.9	50.5	33.2	46.1	58.1
	kW	4.92	4.89	4.86	4.88	4.91	4.95	4.96	4.92	4.90
105	TC	60.4	54.4	49.0	64.2	58.0	52.5	66.7	60.3	55.0
	SHC	20.3	29.1	37.9	24.4	35.6	46.6	28.3	41.8	53.9
	kW	5.43	5.40	5.37	5.39	5.42	5.45	5.47	5.43	5.41
115	TC	55.3	49.7	44.7	58.8	53.1	47.9	61.0	55.1	50.1
	SHC	15.7	24.9	34.0	19.5	31.2	42.5	23.2	37.1	50.0
	kW	5.99	5.96	5.93	5.95	5.98	6.01	6.02	5.99	5.97
125	TC	49.8	44.7	40.1	53.0	47.6	43.0	55.0	49.5	45.0
	SHC	10.7	20.5	30.0	14.3	26.4	38.1	17.8	32.1	45.0
	kW	6.59	6.57	6.55	6.56	6.59	6.61	6.62	6.60	6.58

## RGV/RAV072 — UNIT WITH HOT GAS RE-HEAT SYSTEM IN HOT GAS REHEAT MODE — COOLING CAPACITIES

TEMP (F) AIR ENTERING CONDENSER (Edb)		AIR ENTERING EVAPORATOR — Ewb (F)								
		75 Dry Bulb 62.5 Wet Bulb (50% Relative)			75 Dry Bulb 64 Wet Bulb (56% Relative)			75 Dry Bulb 65.3 Wet Bulb (60% Relative)		
		Air Entering Evaporator — Cfm								
		1800	2400	3000	1800	2400	3000	1800	2400	3000
80	TC	14.02	15.01	15.61	14.70	15.71	16.33	15.30	16.34	16.97
	SHC	-0.84	1.73	4.56	-2.95	-0.90	1.45	-4.78	-3.17	-1.24
	kW	4.15	4.16	4.17	4.17	4.18	4.18	4.18	4.19	4.20
75	TC	15.10	16.17	16.79	15.82	16.89	17.52	16.45	17.54	18.19
	SHC	0.25	2.88	5.72	-1.81	0.29	2.64	-3.59	-1.95	-0.02
	kW	3.96	3.97	3.98	3.98	3.99	4.00	4.00	4.01	4.01
70	TC	15.37	16.68	17.44	16.19	17.39	18.18	17.08	18.37	19.28
	SHC	0.50	3.39	6.36	-1.44	0.78	3.30	-2.94	-1.07	1.12
	kW	3.97	3.93	3.91	3.96	3.95	3.93	3.92	3.89	3.87
60	TC	16.00	16.95	17.50	16.64	17.59	18.16	18.27	18.17	19.09
	SHC	1.11	3.63	6.39	-1.04	0.94	3.23	-1.92	-1.39	0.84
	kW	3.95	3.99	4.01	3.99	4.02	4.04	4.09	4.05	4.01
50	TC	16.10	16.93	17.42	16.68	17.50	18.57	17.19	18.60	19.12
	SHC	1.18	3.58	6.29	-1.05	0.83	3.63	-2.98	-0.98	0.84
	kW	4.03	4.08	4.11	4.07	4.12	4.05	4.12	4.06	4.09
40	TC	16.83	17.62	18.25	17.38	18.17	18.61	17.86	19.42	19.92
	SHC	1.89	4.25	5.84	-0.36	1.47	3.65	-2.32	-0.17	1.62
	kW	3.96	4.02	4.08	4.01	4.08	4.11	4.06	4.00	4.03

### LEGEND

- EWB — Entering wet bulb
- KW — Compressor Power Input
- SCFM/BF — Standard Cubic Feet per Minute/Bypass Factor
- SHC — Sensible Heat Capacity (1000 Btuh) Gross
- TC — Total Capacity (1000 Btuh) Gross

**PRESSURE DROPS FOR ELECTRIC AND GAS HEATING UNITS**

**PRESSURE DROP FOR ELECTRIC HEAT  
3 TO 5 TON UNITS - 1 STAGE HEAT**

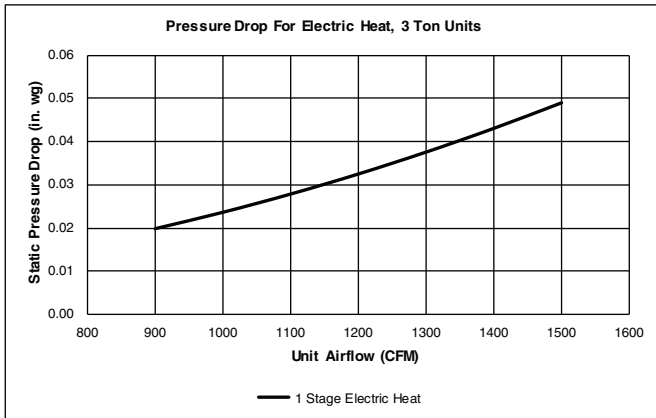

**PRESSURE DROP FOR ELECTRIC HEAT  
4 TO 6 TON UNITS - 1 AND 2 STAGE HEAT**

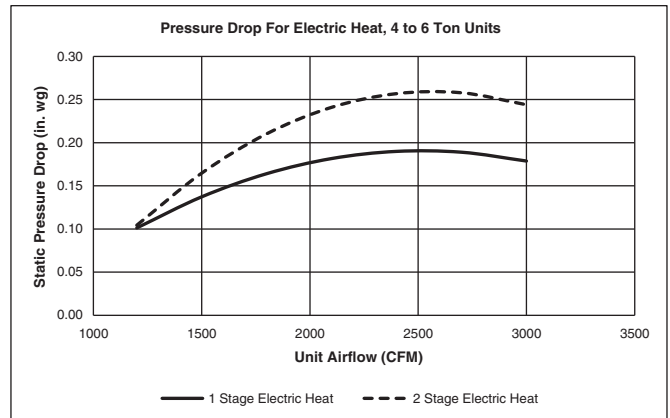

**SINGLE PHASE GAS HEAT STAGES**

UNIT SIZE	HEAT SIZE		
	Low	Med	High
<b>1 Phase</b>			
036	1	1	—
048	1	1	1
060	1	1	1

**THREE PHASE GAS HEAT STAGES**

UNIT SIZE	HEAT SIZE		
	Low	Med	High
<b>3 Phase</b>			
036	1	2	—
048	1	1	2
060	1	1	2
072	1	1	2

**GAS HEAT STATIC PRESSURE DEDUCTIONS – 3 TON UNITS**

CFM	900	1000	1100	1200	1300	1400	1500
<b>Low Gas Heat Deduction</b>	0.01	0.01	0.02	0.03	0.03	0.04	0.04

**GAS HEAT STATIC PRESSURE DEDUCTIONS – 4 TO 6 TON UNITS**

CFM	1200	1500	1800	2100	2400	2700	3000
<b>Medium Gas Heat Deduction</b>	0.01	0.05	0.08	0.12	0.15	0.18	0.20
<b>Low Gas Heat Deduction</b>	0.03	0.10	0.17	0.23	0.29	0.36	0.42

# Performance data (cont)

## FIELD-INSTALLED ACCESSORY ELECTRIC HEATER DATA

RAV UNIT SIZE	VOLTAGE	HEATER MODEL NUMBER*	NUMBER OF STAGES	
036	208/230	CRHEATER323A00	1	
		CRHEATER324A00	1	
		CRHEATER325A00	1	
		CRHEATER326A00	1	
		CRHEATER327A00	2	
		CRHEATER328A00	1	
	460	CRHEATER333A00	1	
		CRHEATER334A00	1	
		CRHEATER335A00	1	
		CRHEATER336A00	1	
		CRHEATER339A00	1	
		CRHEATER340A00	1	
048	208/230	CRHEATER323A00	1	
		CRHEATER324A00	1	
		CRHEATER325A00	1	
		CRHEATER326A00	1	
		CRHEATER327A00	2	
		CRHEATER328A00	1	
		CRHEATER329A00	2	
		CRHEATER330A00†	2	
		CRHEATER331A00**	2	
	460	CRHEATER333A00	1	
		CRHEATER335A00	1	
		CRHEATER336A00	1	
		CRHEATER337A00	2	
	575	CRHEATER339A00	1	
		CRHEATER340A00	1	
	060, 072	208/230	CRHEATER324A00	1
			CRHEATER325A00	1
			CRHEATER326A00	1
CRHEATER327A00			2	
CRHEATER328A00			1	
CRHEATER329A00			2	
CRHEATER331A00			2	
CRHEATER332A00			2	
CRHEATER333A00			1	
460		CRHEATER335A00	1	
		CRHEATER336A00	1	
		CRHEATER337A00	2	
		CRHEATER338A00	2	
575		CRHEATER340A00	1	
		CRHEATER341A00	2	

\*Check heater nameplate for model number.

†Do not use with size 048 horizontal supply duct configuration units.

\*\*Do not use with size 048 vertical supply duct configuration units.

### USE OF CRHEATER330A00 FOR RAV UNITS (WITH OR WITHOUT NON-FUSED DISCONNECT)

DUCT CONFIGURATION	RAV UNIT SIZE			
	036	048	060	072
Vertical Supply	Not available	Available	Available	Available
Horizontal Supply	Not available	Not available	Available	Available

### USE OF CRHEATER331A00 FOR RAV UNITS (WITH OR WITHOUT NON-FUSED DISCONNECT)

DUCT CONFIGURATION	RAV UNIT SIZE			
	036	048	060	072
Vertical Supply	Not available	Not available	Available	Available
Horizontal Supply	Not available	Available	Available	Available

## ECONOMIZER BAROMETRIC RELIEF AND STATIC PRESSURE

### HORIZONTAL ECONOMIZER BAROMETRIC RELIEF

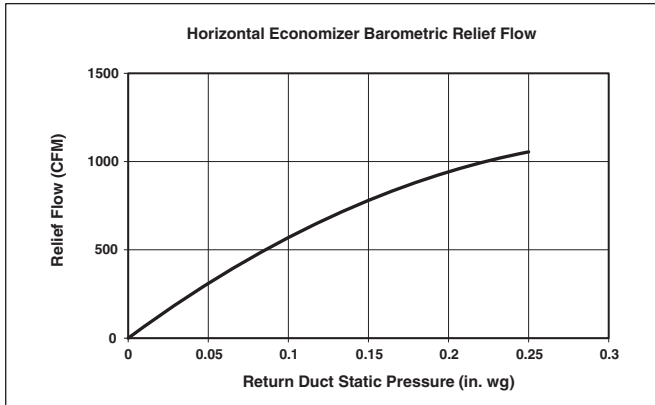

### VERTICAL ECONOMIZER BAROMETRIC RELIEF

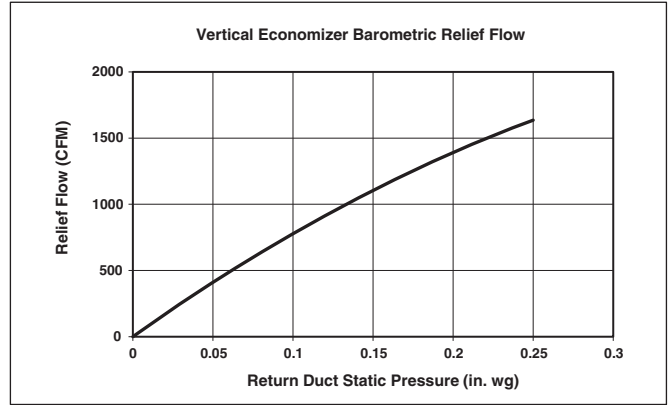

### HORIZONTAL ECONOMIZER DAMPER LEAKAGE

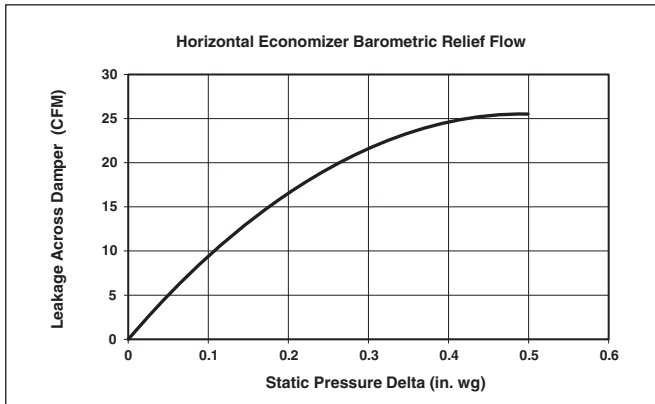

### VERTICAL ECONOMIZER DAMPER LEAKAGE

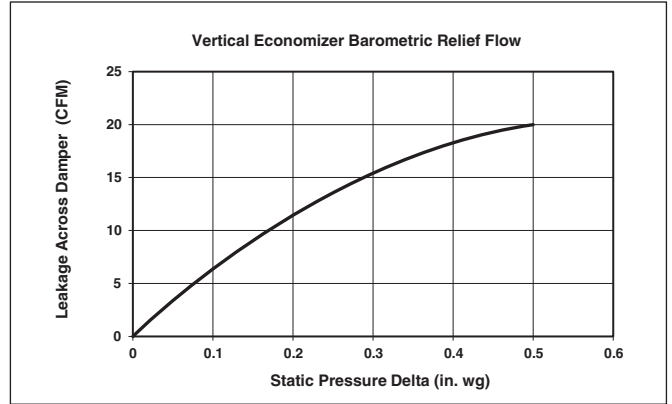

# Performance data (cont)

## HOT GAS RE-HEAT COIL PRESSURE DROPS

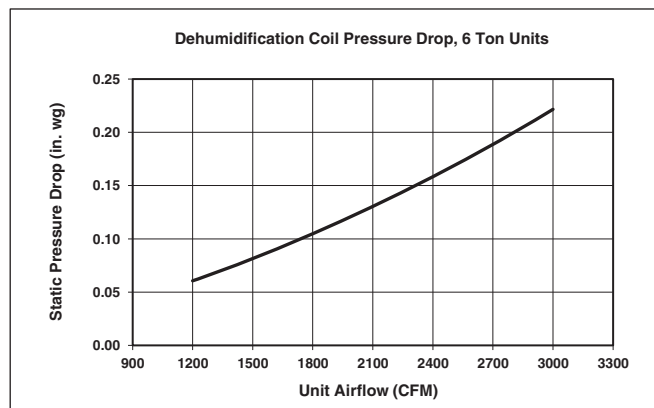
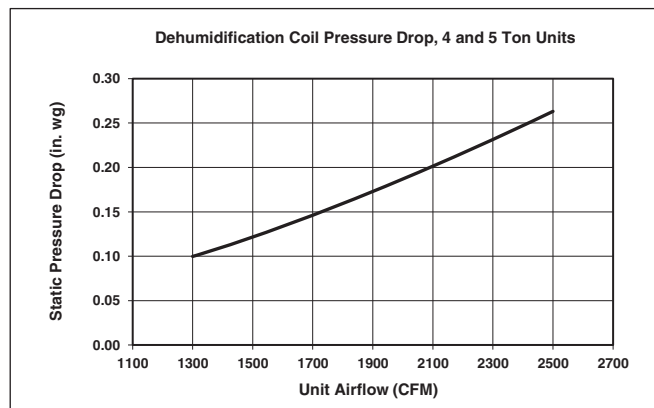
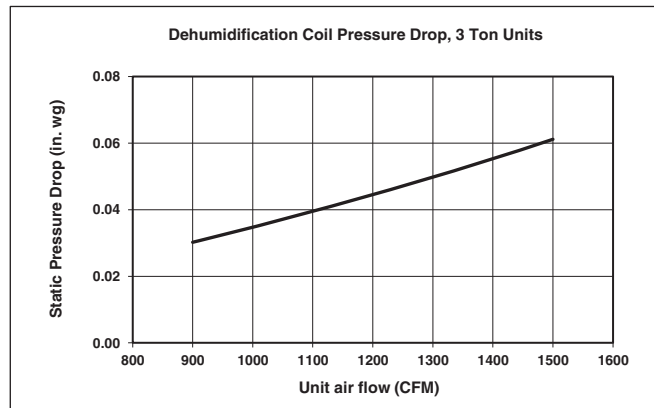

# Fan data

## GENERAL FAN PERFORMANCE NOTES

1. Interpolation is permissible. Do not extrapolate.
2. External static pressure is the static pressure difference between the return duct and the supply duct plus the static pressure caused by any FIOPs or accessories.
3. Tabular data accounts for pressure loss due to clean filters, unit casing, wet coils, and highest gas heat exchanger (when gas heat unit).
4. Factory options and accessories may effect static pressure losses. Gas heat unit fan tables assume highest gas heat models; for fan selections with low or medium heat models, the user must deduct low and medium heat static pressures. Selection software is available, through your salesperson, to help you select the best motor/drive combination for your application.
5. The fan performance tables offer motor/drive recommendations. In cases when two motor/drive combinations would work, ICP recommends the lower horsepower option.
6. For information on the electrical properties of ICP motors, please see the Electrical information section of this book.
7. For more information on the performance limits of ICP motors, see the application data section of this book.
8. The EPACT (Energy Policy Act of 1992) regulates energy requirements for specific types of indoor fan motors. Motors regulated by EPACT include any general purpose, T-frame (three-digit, 143 and larger), single-speed, foot mounted, polyphase, squirrel cage induction motors of NEMA (National Electrical Manufacturers Association) design A and B, manufactured for use in the United States. Ranging from 1 to 200 Hp, these continuous-duty motors operate on 230 and 460 volt, 60 Hz power. If a motor does not fit into these specifications, the motor does not have to be replaced by an EPACT compliant energy-efficient motor. Variable-speed motors are exempt from EPACT compliance requirements.

# Fan data (cont)

## RGV036 SINGLE PHASE — 3 TON VERTICAL SUPPLY (RPM - BHP)

CFM	AVAILABLE EXTERNAL STATIC PRESSURE (in. wg)									
	0.2		0.4		0.6		0.8		1.0	
	RPM	BHP	RPM	BHP	RPM	BHP	RPM	BHP	RPM	BHP
900	1112	0.10	1341	0.17	1530	0.25	1696	0.34	1845	0.44
975	1162	0.11	1385	0.19	1571	0.27	1733	0.36	1881	0.46
1050	1213	0.12	1431	0.20	1613	0.29	1772	0.39	1917	0.49
1125	1265	0.14	1477	0.22	1656	0.32	1813	0.41	1956	0.52
1200	1319	0.16	1525	0.25	1700	0.34	1855	0.44	1996	0.55
1275	1374	0.18	1573	0.27	1746	0.37	1898	0.48	2037	0.59
1350	1430	0.20	1623	0.30	1792	0.40	1942	0.51	2079	0.63
1425	1487	0.23	1674	0.33	1839	0.43	1987	0.55	2122	0.67
1500	1545	0.26	1725	0.36	1887	0.47	2032	0.58	2165	0.71

CFM	AVAILABLE EXTERNAL STATIC PRESSURE (in. wg)									
	1.2		1.4		1.6		1.8		2.0	
	RPM	BHP	RPM	BHP	RPM	BHP	RPM	BHP	RPM	BHP
900	1983	0.54	2111	0.66	2231	0.77	2344	0.90	2452	1.03
975	2016	0.57	2143	0.69	2262	0.81	2375	0.93	2482	1.06
1050	2051	0.60	2177	0.72	2294	0.84	2406	0.97	—	—
1125	2088	0.63	2211	0.75	2328	0.88	2438	1.01	—	—
1200	2126	0.67	2248	0.79	2363	0.92	2472	1.05	—	—
1275	2165	0.71	2285	0.83	2399	0.96	—	—	—	—
1350	2205	0.75	2324	0.87	2437	1.01	—	—	—	—
1425	2247	0.79	2364	0.92	2475	1.06	—	—	—	—
1500	2289	0.84	2405	0.97	—	—	—	—	—	—

Standard Static 1112-1890 RPM, 0.44 Max BHP

Medium Static 1112-2190 RPM, 0.71 Max BHP

High Static 1112-2490 RPM, 1.07 Max BHP

NOTE: Fan tables include highest gas heat. Utilize static pressure deduction tables for lower gas heat capacities.

## RGV036 SINGLE PHASE – STANDARD STATIC — 3 TON VERTICAL SUPPLY (RPM - VDC)

CFM	AVAILABLE EXTERNAL STATIC PRESSURE (in. wg)									
	0.2		0.4		0.6		0.8		1.0	
	RPM	Vdc	RPM	Vdc	RPM	Vdc	RPM	Vdc	RPM	Vdc
900	1112	5.9	1341	7.1	1530	8.1	1696	9.0	1845	9.8
975	1162	6.1	1385	7.3	1571	8.3	1733	9.2	—	—
1050	1213	6.4	1431	7.6	1613	8.5	1772	9.4	—	—
1125	1265	6.7	1477	7.8	1656	8.8	1813	9.6	—	—
1200	1319	7.0	1525	8.1	1700	9.0	1855	9.8	—	—
1275	1374	7.3	1573	8.3	1746	9.2	—	—	—	—
1350	1430	7.6	1623	8.6	1792	9.5	—	—	—	—
1425	1487	7.9	1674	8.9	1839	9.7	—	—	—	—
1500	1545	8.2	1725	9.1	—	—	—	—	—	—

CFM	AVAILABLE EXTERNAL STATIC PRESSURE (in. wg)									
	1.2		1.4		1.6		1.8		2.0	
	RPM	Vdc	RPM	Vdc	RPM	Vdc	RPM	Vdc	RPM	Vdc
900	—	—	—	—	—	—	—	—	—	—
975	—	—	—	—	—	—	—	—	—	—
1050	—	—	—	—	—	—	—	—	—	—
1125	—	—	—	—	—	—	—	—	—	—
1200	—	—	—	—	—	—	—	—	—	—
1275	—	—	—	—	—	—	—	—	—	—
1350	—	—	—	—	—	—	—	—	—	—
1425	—	—	—	—	—	—	—	—	—	—
1500	—	—	—	—	—	—	—	—	—	—

Standard Static 1112-1890 RPM

NOTE: Fan tables include highest gas heat. Utilize static pressure deduction tables for lower gas heat capacities.

**RGV036 SINGLE PHASE – MEDIUM STATIC — 3 TON VERTICAL SUPPLY (RPM - VDC)**

CFM	AVAILABLE EXTERNAL STATIC PRESSURE (in. wg)									
	0.2		0.4		0.6		0.8		1.0	
	RPM	Vdc	RPM	Vdc	RPM	Vdc	RPM	Vdc	RPM	Vdc
900	1112	5.1	1341	6.1	1530	7.0	1696	7.7	1845	8.4
975	1162	5.3	1385	6.3	1571	7.2	1733	7.9	1881	8.6
1050	1213	5.5	1431	6.5	1613	7.4	1772	8.1	1917	8.8
1125	1265	5.8	1477	6.7	1656	7.6	1813	8.3	1956	8.9
1200	1319	6.0	1525	7.0	1700	7.8	1855	8.5	1996	9.1
1275	1374	6.3	1573	7.2	1746	8.0	1898	8.7	2037	9.3
1350	1430	6.5	1623	7.4	1792	8.2	1942	8.9	2079	9.5
1425	1487	6.8	1674	7.6	1839	8.4	1987	9.1	2122	9.7
1500	1545	7.1	1725	7.9	1887	8.6	2032	9.3	2165	9.9

CFM	AVAILABLE EXTERNAL STATIC PRESSURE (in. wg)									
	1.2		1.4		1.6		1.8		2.0	
	RPM	Vdc	RPM	Vdc	RPM	Vdc	RPM	Vdc	RPM	Vdc
900	1983	9.1	2111	9.6	—	—	—	—	—	—
975	2016	9.2	2143	9.8	—	—	—	—	—	—
1050	2051	9.4	—	—	—	—	—	—	—	—
1125	2088	9.5	—	—	—	—	—	—	—	—
1200	2126	9.7	—	—	—	—	—	—	—	—
1275	2165	9.9	—	—	—	—	—	—	—	—
1350	—	—	—	—	—	—	—	—	—	—
1425	—	—	—	—	—	—	—	—	—	—
1500	—	—	—	—	—	—	—	—	—	—

Medium Static 1112-2190 RPM

NOTE: Fan tables include highest gas heat. Utilize static pressure deduction tables for lower gas heat capacities.

**RGV036 SINGLE PHASE – HIGH STATIC — 3 TON VERTICAL SUPPLY (PRM - VDC)**

CFM	AVAILABLE EXTERNAL STATIC PRESSURE (in. wg)									
	0.2		0.4		0.6		0.8		1.0	
	RPM	Vdc	RPM	Vdc	RPM	Vdc	RPM	Vdc	RPM	Vdc
900	1112	4.5	1341	5.4	1530	6.1	1696	6.8	1845	7.4
975	1162	4.7	1385	5.6	1571	6.3	1733	7.0	1881	7.6
1050	1213	4.9	1431	5.7	1613	6.5	1772	7.1	1917	7.7
1125	1265	5.1	1477	5.9	1656	6.7	1813	7.3	1956	7.9
1200	1319	5.3	1525	6.1	1700	6.8	1855	7.4	1996	8.0
1275	1374	5.5	1573	6.3	1746	7.0	1898	7.6	2037	8.2
1350	1430	5.7	1623	6.5	1792	7.2	1942	7.8	2079	8.3
1425	1487	6.0	1674	6.7	1839	7.4	1987	8.0	2122	8.5
1500	1545	6.2	1725	6.9	1887	7.6	2032	8.2	2165	8.7

CFM	AVAILABLE EXTERNAL STATIC PRESSURE (in. wg)									
	1.2		1.4		1.6		1.8		2.0	
	RPM	Vdc	RPM	Vdc	RPM	Vdc	RPM	Vdc	RPM	Vdc
900	1983	8.0	2111	8.5	2231	9.0	2344	9.4	2452	9.8
975	2016	8.1	2143	8.6	2262	9.1	2375	9.5	2482	10.0
1050	2051	8.2	2177	8.7	2294	9.2	2406	9.7	—	—
1125	2088	8.4	2211	8.9	2328	9.3	2438	9.8	—	—
1200	2126	8.5	2248	9.0	2363	9.5	2472	9.9	—	—
1275	2165	8.7	2285	9.2	2399	9.6	—	—	—	—
1350	2205	8.9	2324	9.3	2437	9.8	—	—	—	—
1425	2247	9.0	2364	9.5	2475	9.9	—	—	—	—
1500	2289	9.2	2405	9.7	—	—	—	—	—	—

High Static 1112-2490 RPM

NOTE: Fan tables include highest gas heat. Utilize static pressure deduction tables for lower gas heat capacities.

# Fan data (cont)

## RGV036 THREE PHASE — 3 TON VERTICAL SUPPLY (RPM - BHP)

CFM	AVAILABLE EXTERNAL STATIC PRESSURE (in. wg)									
	0.2		0.4		0.6		0.8		1.0	
	RPM	BHP	RPM	BHP	RPM	BHP	RPM	BHP	RPM	BHP
900	1112	0.10	1341	0.17	1530	0.25	1696	0.34	1845	0.44
975	1162	0.11	1385	0.19	1571	0.27	1733	0.36	1881	0.46
1050	1213	0.12	1431	0.20	1613	0.29	1772	0.39	1917	0.49
1125	1265	0.14	1477	0.22	1656	0.32	1813	0.41	1956	0.52
1200	1319	0.16	1525	0.25	1700	0.34	1855	0.44	1996	0.55
1275	1374	0.18	1573	0.27	1746	0.37	1898	0.48	2037	0.59
1350	1430	0.20	1623	0.30	1792	0.40	1942	0.51	2079	0.63
1425	1487	0.23	1674	0.33	1839	0.43	1987	0.55	2122	0.67
1500	1545	0.26	1725	0.36	1887	0.47	2032	0.58	2165	0.71

CFM	AVAILABLE EXTERNAL STATIC PRESSURE (in. wg)									
	1.2		1.4		1.6		1.8		2.0	
	RPM	BHP	RPM	BHP	RPM	BHP	RPM	BHP	RPM	BHP
900	1983	0.54	2111	0.66	2231	0.77	2344	0.90	2452	1.03
975	2016	0.57	2143	0.69	2262	0.81	2375	0.93	2482	1.06
1050	2051	0.60	2177	0.72	2294	0.84	2406	0.97	—	—
1125	2088	0.63	2211	0.75	2328	0.88	2438	1.01	—	—
1200	2126	0.67	2248	0.79	2363	0.92	2472	1.05	—	—
1275	2165	0.71	2285	0.83	2399	0.96	—	—	—	—
1350	2205	0.75	2324	0.87	2437	1.01	—	—	—	—
1425	2247	0.79	2364	0.92	2475	1.06	—	—	—	—
1500	2289	0.84	2405	0.97	—	—	—	—	—	—

Standard Static 1112-1890 RPM, 0.44 Max BHP

Medium Static 1112-2190 RPM, 0.71 Max BHP

High Static 1112-2490 RPM, 1.07 Max BHP

NOTE: Fan tables include highest gas heat. Utilize static pressure deduction tables for lower gas heat capacities.

## RGV036 THREE PHASE – STANDARD STATIC — 3 TON VERTICAL SUPPLY (RPM - VDC)

CFM	AVAILABLE EXTERNAL STATIC PRESSURE (in. wg)									
	0.2		0.4		0.6		0.8		1.0	
	RPM	Vdc	RPM	Vdc	RPM	Vdc	RPM	Vdc	RPM	Vdc
900	1112	5.9	1341	7.1	1530	8.1	1696	9.0	1845	9.8
975	1162	6.1	1385	7.3	1571	8.3	1733	9.2	—	—
1050	1213	6.4	1431	7.6	1613	8.5	1772	9.4	—	—
1125	1265	6.7	1477	7.8	1656	8.8	1813	9.6	—	—
1200	1319	7.0	1525	8.1	1700	9.0	1855	9.8	—	—
1275	1374	7.3	1573	8.3	1746	9.2	—	—	—	—
1350	1430	7.6	1623	8.6	1792	9.5	—	—	—	—
1425	1487	7.9	1674	8.9	1839	9.7	—	—	—	—
1500	1545	8.2	1725	9.1	—	—	—	—	—	—

CFM	AVAILABLE EXTERNAL STATIC PRESSURE (in. wg)									
	1.2		1.4		1.6		1.8		2.0	
	RPM	Vdc	RPM	Vdc	RPM	Vdc	RPM	Vdc	RPM	Vdc
900	—	—	—	—	—	—	—	—	—	—
975	—	—	—	—	—	—	—	—	—	—
1050	—	—	—	—	—	—	—	—	—	—
1125	—	—	—	—	—	—	—	—	—	—
1200	—	—	—	—	—	—	—	—	—	—
1275	—	—	—	—	—	—	—	—	—	—
1350	—	—	—	—	—	—	—	—	—	—
1425	—	—	—	—	—	—	—	—	—	—
1500	—	—	—	—	—	—	—	—	—	—

Standard Static 1112-1890 RPM

NOTE: Fan tables include highest gas heat. Utilize static pressure deduction tables for lower gas heat capacities.

**RGV036 THREE PHASE – MEDIUM STATIC — 3 TON VERTICAL SUPPLY (RPM - VDC)**

CFM	AVAILABLE EXTERNAL STATIC PRESSURE (in. wg)									
	0.2		0.4		0.6		0.8		1.0	
	RPM	Vdc	RPM	Vdc	RPM	Vdc	RPM	Vdc	RPM	Vdc
900	1112	5.1	1341	6.1	1530	7.0	1696	7.7	1845	8.4
975	1162	5.3	1385	6.3	1571	7.2	1733	7.9	1881	8.6
1050	1213	5.5	1431	6.5	1613	7.4	1772	8.1	1917	8.8
1125	1265	5.8	1477	6.7	1656	7.6	1813	8.3	1956	8.9
1200	1319	6.0	1525	7.0	1700	7.8	1855	8.5	1996	9.1
1275	1374	6.3	1573	7.2	1746	8.0	1898	8.7	2037	9.3
1350	1430	6.5	1623	7.4	1792	8.2	1942	8.9	2079	9.5
1425	1487	6.8	1674	7.6	1839	8.4	1987	9.1	2122	9.7
1500	1545	7.1	1725	7.9	1887	8.6	2032	9.3	2165	9.9

CFM	AVAILABLE EXTERNAL STATIC PRESSURE (in. wg)									
	1.2		1.4		1.6		1.8		2.0	
	RPM	Vdc	RPM	Vdc	RPM	Vdc	RPM	Vdc	RPM	Vdc
900	1983	9.1	2111	9.6	—	—	—	—	—	—
975	2016	9.2	2143	9.8	—	—	—	—	—	—
1050	2051	9.4	—	—	—	—	—	—	—	—
1125	2088	9.5	—	—	—	—	—	—	—	—
1200	2126	9.7	—	—	—	—	—	—	—	—
1275	2165	9.9	—	—	—	—	—	—	—	—
1350	—	—	—	—	—	—	—	—	—	—
1425	—	—	—	—	—	—	—	—	—	—
1500	—	—	—	—	—	—	—	—	—	—

Medium Static 1112-2190 RPM

NOTE: Fan tables include highest gas heat. Utilize static pressure deduction tables for lower gas heat capacities.

**RGV036 THREE PHASE – HIGH STATIC — 3 TON VERTICAL SUPPLY (RPM - VDC)**

CFM	AVAILABLE EXTERNAL STATIC PRESSURE (in. wg)									
	0.2		0.4		0.6		0.8		1.0	
	RPM	Vdc	RPM	Vdc	RPM	Vdc	RPM	Vdc	RPM	Vdc
900	1112	4.5	1341	5.4	1530	6.1	1696	6.8	1845	7.4
975	1162	4.7	1385	5.6	1571	6.3	1733	7.0	1881	7.6
1050	1213	4.9	1431	5.7	1613	6.5	1772	7.1	1917	7.7
1125	1265	5.1	1477	5.9	1656	6.7	1813	7.3	1956	7.9
1200	1319	5.3	1525	6.1	1700	6.8	1855	7.4	1996	8.0
1275	1374	5.5	1573	6.3	1746	7.0	1898	7.6	2037	8.2
1350	1430	5.7	1623	6.5	1792	7.2	1942	7.8	2079	8.3
1425	1487	6.0	1674	6.7	1839	7.4	1987	8.0	2122	8.5
1500	1545	6.2	1725	6.9	1887	7.6	2032	8.2	2165	8.7

CFM	AVAILABLE EXTERNAL STATIC PRESSURE (in. wg)									
	1.2		1.4		1.6		1.8		2.0	
	RPM	Vdc	RPM	Vdc	RPM	Vdc	RPM	Vdc	RPM	Vdc
900	1983	8.0	2111	8.5	2231	9.0	2344	9.4	2452	9.8
975	2016	8.1	2143	8.6	2262	9.1	2375	9.5	2482	10.0
1050	2051	8.2	2177	8.7	2294	9.2	2406	9.7	—	—
1125	2088	8.4	2211	8.9	2328	9.3	2438	9.8	—	—
1200	2126	8.5	2248	9.0	2363	9.5	2472	9.9	—	—
1275	2165	8.7	2285	9.2	2399	9.6	—	—	—	—
1350	2205	8.9	2324	9.3	2437	9.8	—	—	—	—
1425	2247	9.0	2364	9.5	2475	9.9	—	—	—	—
1500	2289	9.2	2405	9.7	—	—	—	—	—	—

High Static 1112-2490 RPM

NOTE: Fan tables include highest gas heat. Utilize static pressure deduction tables for lower gas heat capacities.

# Fan data (cont)

## RGV048 SINGLE PHASE — 4 TON VERTICAL SUPPLY (RPM - BHP)

CFM	AVAILABLE EXTERNAL STATIC PRESSURE (in. wg)									
	0.2		0.4		0.6		0.8		1.0	
	RPM	BHP	RPM	BHP	RPM	BHP	RPM	BHP	RPM	BHP
1200	1262	0.21	1452	0.33	1614	0.45	1757	0.58	1888	0.72
1300	1333	0.25	1516	0.37	1674	0.50	1813	0.63	1942	0.78
1400	1405	0.29	1583	0.42	1735	0.55	1872	0.70	1997	0.84
1500	1478	0.34	1650	0.48	1798	0.62	1932	0.76	2054	0.92
1600	1552	0.40	1718	0.54	1863	0.68	1993	0.84	2114	1.00
1700	1627	0.46	1787	0.60	1928	0.76	2057	0.92	2174	1.09
1800	1704	0.52	1857	0.68	1995	0.84	2121	1.01	2236	1.18
1900	1781	0.60	1929	0.76	2063	0.93	2185	1.10	2299	1.28
2000	1859	0.68	2001	0.85	2132	1.02	2252	1.21	2363	1.39

CFM	AVAILABLE EXTERNAL STATIC PRESSURE (in. wg)									
	1.2		1.4		1.6		1.8		2.0	
	RPM	BHP	RPM	BHP	RPM	BHP	RPM	BHP	RPM	BHP
1200	2011	0.87	2126	1.02	2236	1.19	2341	1.37	2442	1.55
1300	2061	0.93	2174	1.09	2281	1.26	2384	1.44	—	—
1400	2114	1.00	2224	1.17	2329	1.34	2429	1.52	—	—
1500	2169	1.08	2277	1.25	2379	1.43	—	—	—	—
1600	2226	1.17	2331	1.34	2432	1.52	—	—	—	—
1700	2284	1.26	2388	1.44	—	—	—	—	—	—
1800	2344	1.36	2446	1.55	—	—	—	—	—	—
1900	2405	1.47	—	—	—	—	—	—	—	—
2000	—	—	—	—	—	—	—	—	—	—

Standard Static 1262-1900 RPM, 0.72 Max BHP

Medium Static 1262-2170 RPM, 1.06 Max BHP

High Static 1262-2460 RPM, 1.53 Max BHP

NOTE: Fan tables include highest gas heat. Utilize static pressure deduction tables for lower gas heat capacities.

## RGV048 SINGLE PHASE – STANDARD STATIC — 4 TON VERTICAL SUPPLY (RPM - VDC)

CFM	AVAILABLE EXTERNAL STATIC PRESSURE (in. wg)									
	0.2		0.4		0.6		0.8		1.0	
	RPM	Vdc	RPM	Vdc	RPM	Vdc	RPM	Vdc	RPM	Vdc
1200	1262	6.6	1452	7.6	1614	8.5	1757	9.2	1888	9.9
1300	1333	7.0	1516	8.0	1674	8.8	1813	9.5	—	—
1400	1405	7.4	1583	8.3	1735	9.1	1872	9.9	—	—
1500	1478	7.8	1650	8.7	1798	9.5	—	—	—	—
1600	1552	8.2	1718	9.0	1863	9.8	—	—	—	—
1700	1627	8.6	1787	9.4	—	—	—	—	—	—
1800	1704	9.0	1857	9.8	—	—	—	—	—	—
1900	1781	9.4	—	—	—	—	—	—	—	—
2000	1859	9.8	—	—	—	—	—	—	—	—

CFM	AVAILABLE EXTERNAL STATIC PRESSURE (in. wg)									
	1.2		1.4		1.6		1.8		2.0	
	RPM	Vdc	RPM	Vdc	RPM	Vdc	RPM	Vdc	RPM	Vdc
1200	—	—	—	—	—	—	—	—	—	—
1300	—	—	—	—	—	—	—	—	—	—
1400	—	—	—	—	—	—	—	—	—	—
1500	—	—	—	—	—	—	—	—	—	—
1600	—	—	—	—	—	—	—	—	—	—
1700	—	—	—	—	—	—	—	—	—	—
1800	—	—	—	—	—	—	—	—	—	—
1900	—	—	—	—	—	—	—	—	—	—
2000	—	—	—	—	—	—	—	—	—	—

Standard Static 1262-1900 RPM

NOTE: Fan tables include highest gas heat. Utilize static pressure deduction tables for lower gas heat capacities.

**RGV 48 SINGLE PHASE – MEDIUM STATIC — 4 TON VERTICAL SUPPLY (RPM - VDC)**

CFM	AVAILABLE EXTERNAL STATIC PRESSURE (in. wg)									
	0.2		0.4		0.6		0.8		1.0	
	RPM	Vdc	RPM	Vdc	RPM	Vdc	RPM	Vdc	RPM	Vdc
1200	1262	5.8	1452	6.7	1614	7.4	1757	8.1	1888	8.7
1300	1333	6.1	1516	7.0	1674	7.7	1813	8.4	1942	8.9
1400	1405	6.5	1583	7.3	1735	8.0	1872	8.6	1997	9.2
1500	1478	6.8	1650	7.6	1798	8.3	1932	8.9	2054	9.5
1600	1552	7.2	1718	7.9	1863	8.6	1993	9.2	2114	9.7
1700	1627	7.5	1787	8.2	1928	8.9	2057	9.5	—	—
1800	1704	7.9	1857	8.6	1995	9.2	2121	9.8	—	—
1900	1781	8.2	1929	8.9	2063	9.5	—	—	—	—
2000	1859	8.6	2001	9.2	2132	9.8	—	—	—	—

CFM	AVAILABLE EXTERNAL STATIC PRESSURE (in. wg)									
	1.2		1.4		1.6		1.8		2.0	
	RPM	Vdc	RPM	Vdc	RPM	Vdc	RPM	Vdc	RPM	Vdc
1200	2011	9.3	2126	9.8	—	—	—	—	—	—
1300	2061	9.5	—	—	—	—	—	—	—	—
1400	2114	9.7	—	—	—	—	—	—	—	—
1500	2169	10.0	—	—	—	—	—	—	—	—
1600	—	—	—	—	—	—	—	—	—	—
1700	—	—	—	—	—	—	—	—	—	—
1800	—	—	—	—	—	—	—	—	—	—
1900	—	—	—	—	—	—	—	—	—	—
2000	—	—	—	—	—	—	—	—	—	—

Medium Static 1262-2170 RPM

NOTE: Fan tables include highest gas heat. Utilize static pressure deduction tables for lower gas heat capacities.

**RGV048 SINGLE PHASE – HIGH STATIC — 4 TON VERTICAL SUPPLY (RPM - VDC)**

CFM	AVAILABLE EXTERNAL STATIC PRESSURE (in. wg)									
	0.2		0.4		0.6		0.8		1.0	
	RPM	Vdc	RPM	Vdc	RPM	Vdc	RPM	Vdc	RPM	Vdc
1200	1262	5.1	1452	5.9	1614	6.6	1757	7.1	1888	7.7
1300	1333	5.4	1516	6.2	1674	6.8	1813	7.4	1942	7.9
1400	1405	5.7	1583	6.4	1735	7.1	1872	7.6	1997	8.1
1500	1478	6.0	1650	6.7	1798	7.3	1932	7.9	2054	8.3
1600	1552	6.3	1718	7.0	1863	7.6	1993	8.1	2114	8.6
1700	1627	6.6	1787	7.3	1928	7.8	2057	8.4	2174	8.8
1800	1704	6.9	1857	7.5	1995	8.1	2121	8.6	2236	9.1
1900	1781	7.2	1929	7.8	2063	8.4	2185	8.9	2299	9.3
2000	1859	7.6	2001	8.1	2132	8.7	2252	9.2	2363	9.6

CFM	AVAILABLE EXTERNAL STATIC PRESSURE (in. wg)									
	1.2		1.4		1.6		1.8		2.0	
	RPM	Vdc	RPM	Vdc	RPM	Vdc	RPM	Vdc	RPM	Vdc
1200	2011	8.2	2126	8.6	2236	9.1	2341	9.5	2442	9.9
1300	2061	8.4	2174	8.8	2281	9.3	2384	9.7	—	—
1400	2114	8.6	2224	9.0	2329	9.5	2429	9.9	—	—
1500	2169	8.8	2277	9.3	2379	9.7	—	—	—	—
1600	2226	9.0	2331	9.5	2432	9.9	—	—	—	—
1700	2284	9.3	2388	9.7	—	—	—	—	—	—
1800	2344	9.5	2446	9.9	—	—	—	—	—	—
1900	2405	9.8	—	—	—	—	—	—	—	—
2000	—	—	—	—	—	—	—	—	—	—

High Static 1262-2460 RPM

NOTE: Fan tables include highest gas heat. Utilize static pressure deduction tables for lower gas heat capacities.

# Fan data (cont)

## RGV048 THREE PHASE — 4 TON VERTICAL SUPPLY (RPM - BHP)

CFM	AVAILABLE EXTERNAL STATIC PRESSURE (in. wg)									
	0.2		0.4		0.6		0.8		1.0	
	RPM	BHP	RPM	BHP	RPM	BHP	RPM	BHP	RPM	BHP
1200	1262	0.21	1453	0.33	1614	0.45	1757	0.58	1888	0.72
1300	1333	0.25	1517	0.37	1674	0.50	1814	0.63	1942	0.78
1400	1405	0.29	1583	0.42	1736	0.56	1872	0.70	1998	0.85
1500	1478	0.34	1650	0.48	1799	0.62	1932	0.76	2055	0.92
1600	1553	0.40	1718	0.54	1863	0.68	1994	0.84	2114	1.00
1700	1628	0.46	1787	0.60	1929	0.76	2057	0.92	2174	1.09
1800	1704	0.52	1858	0.68	1995	0.84	2121	1.01	2236	1.18
1900	1781	0.60	1929	0.76	2063	0.93	2186	1.10	2299	1.28
2000	1859	0.68	2001	0.85	2132	1.02	2252	1.21	2363	1.39

CFM	AVAILABLE EXTERNAL STATIC PRESSURE (in. wg)									
	1.2		1.4		1.6		1.8		2.0	
	RPM	BHP	RPM	BHP	RPM	BHP	RPM	BHP	RPM	BHP
1200	2011	0.87	2126	1.02	2236	1.19	2341	1.37	2442	1.55
1300	2061	0.93	2174	1.09	2281	1.26	2383	1.44	2482	1.62
1400	2114	1.00	2224	1.17	2329	1.34	2429	1.52	2526	1.71
1500	2169	1.08	2277	1.25	2379	1.43	2478	1.61	2572	1.80
1600	2226	1.17	2332	1.34	2432	1.52	2528	1.71	2621	1.91
1700	2284	1.26	2388	1.44	2487	1.63	2581	1.82	—	—
1800	2344	1.36	2446	1.55	2543	1.74	2636	1.94	—	—
1900	2405	1.47	2505	1.66	2600	1.86	—	—	—	—
2000	2467	1.59	2566	1.79	2659	1.99	—	—	—	—

Standard Static 1262-1900 RPM, 0.72 Max BHP

Medium Static 1262-2170 RPM, 1.06 Max BHP

High Static 1262-2660 RPM, 1.92 Max BHP

NOTE: Fan tables include highest gas heat. Utilize static pressure deduction tables for lower gas heat capacities.

## RGV048 THREE PHASE – STANDARD STATIC — 4 TON VERTICAL SUPPLY (RPM - VDC)

CFM	AVAILABLE EXTERNAL STATIC PRESSURE (in. wg)									
	0.2		0.4		0.6		0.8		1.0	
	RPM	Vdc	RPM	Vdc	RPM	Vdc	RPM	Vdc	RPM	Vdc
1200	1262	6.6	1453	7.6	1614	8.5	1757	9.2	1888	9.9
1300	1333	7.0	1517	8.0	1674	8.8	1814	9.5	—	—
1400	1405	7.4	1583	8.3	1736	9.1	1872	9.9	—	—
1500	1478	7.8	1650	8.7	1799	9.5	—	—	—	—
1600	1553	8.2	1718	9.0	1863	9.8	—	—	—	—
1700	1628	8.6	1787	9.4	—	—	—	—	—	—
1800	1704	9.0	1858	9.8	—	—	—	—	—	—
1900	1781	9.4	—	—	—	—	—	—	—	—
2000	1859	9.8	—	—	—	—	—	—	—	—

CFM	AVAILABLE EXTERNAL STATIC PRESSURE (in. wg)									
	1.2		1.4		1.6		1.8		2.0	
	RPM	Vdc	RPM	Vdc	RPM	Vdc	RPM	Vdc	RPM	Vdc
1200	—	—	—	—	—	—	—	—	—	—
1300	—	—	—	—	—	—	—	—	—	—
1400	—	—	—	—	—	—	—	—	—	—
1500	—	—	—	—	—	—	—	—	—	—
1600	—	—	—	—	—	—	—	—	—	—
1700	—	—	—	—	—	—	—	—	—	—
1800	—	—	—	—	—	—	—	—	—	—
1900	—	—	—	—	—	—	—	—	—	—
2000	—	—	—	—	—	—	—	—	—	—

Standard Static 1262-1900 RPM

NOTE: Fan tables include highest gas heat. Utilize static pressure deduction tables for lower gas heat capacities.

**RGV048 THREE PHASE – MEDIUM STATIC — 4 TON VERTICAL SUPPLY (RPM - VDC)**

CFM	AVAILABLE EXTERNAL STATIC PRESSURE (in. wg)									
	0.2		0.4		0.6		0.8		1.0	
	RPM	Vdc	RPM	Vdc	RPM	Vdc	RPM	Vdc	RPM	Vdc
1200	1262	5.8	1453	6.7	1614	7.4	1757	8.1	1888	8.7
1300	1333	6.1	1517	7.0	1674	7.7	1814	8.4	1942	8.9
1400	1405	6.5	1583	7.3	1736	8.0	1872	8.6	1998	9.2
1500	1478	6.8	1650	7.6	1799	8.3	1932	8.9	2055	9.5
1600	1553	7.2	1718	7.9	1863	8.6	1994	9.2	2114	9.7
1700	1628	7.5	1787	8.2	1929	8.9	2057	9.5	—	—
1800	1704	7.9	1858	8.6	1995	9.2	2121	9.8	—	—
1900	1781	8.2	1929	8.9	2063	9.5	—	—	—	—
2000	1859	8.6	2001	9.2	2132	9.8	—	—	—	—

CFM	AVAILABLE EXTERNAL STATIC PRESSURE (in. wg)									
	1.2		1.4		1.6		1.8		2.0	
	RPM	Vdc	RPM	Vdc	RPM	Vdc	RPM	Vdc	RPM	Vdc
1200	2011	9.3	2126	9.8	—	—	—	—	—	—
1300	2061	9.5	—	—	—	—	—	—	—	—
1400	2114	9.7	—	—	—	—	—	—	—	—
1500	2169	10.0	—	—	—	—	—	—	—	—
1600	—	—	—	—	—	—	—	—	—	—
1700	—	—	—	—	—	—	—	—	—	—
1800	—	—	—	—	—	—	—	—	—	—
1900	—	—	—	—	—	—	—	—	—	—
2000	—	—	—	—	—	—	—	—	—	—

Medium Static 1262-2170 RPM

NOTE: Fan tables include highest gas heat. Utilize static pressure deduction tables for lower gas heat capacities.

**RGV048 THREE PHASE – HIGH STATIC — 4 TON VERTICAL SUPPLY (RPM - VDC)**

CFM	AVAILABLE EXTERNAL STATIC PRESSURE (in. wg)									
	0.2		0.4		0.6		0.8		1.0	
	RPM	Vdc	RPM	Vdc	RPM	Vdc	RPM	Vdc	RPM	Vdc
1200	1262	4.7	1453	5.5	1614	6.1	1757	6.6	1888	7.1
1300	1333	5.0	1517	5.7	1674	6.3	1814	6.8	1942	7.3
1400	1405	5.3	1583	6.0	1736	6.5	1872	7.0	1998	7.5
1500	1478	5.6	1650	6.2	1799	6.8	1932	7.3	2055	7.7
1600	1553	5.8	1718	6.5	1863	7.0	1994	7.5	2114	7.9
1700	1628	6.1	1787	6.7	1929	7.3	2057	7.7	2174	8.2
1800	1704	6.4	1858	7.0	1995	7.5	2121	8.0	2236	8.4
1900	1781	6.7	1929	7.3	2063	7.8	2186	8.2	2299	8.6
2000	1859	7.0	2001	7.5	2132	8.0	2252	8.5	2363	8.9

CFM	AVAILABLE EXTERNAL STATIC PRESSURE (in. wg)									
	1.2		1.4		1.6		1.8		2.0	
	RPM	Vdc	RPM	Vdc	RPM	Vdc	RPM	Vdc	RPM	Vdc
1200	2011	7.6	2126	8.0	2236	8.4	2341	8.8	2442	9.2
1300	2061	7.7	2174	8.2	2281	8.6	2383	9.0	2482	9.3
1400	2114	7.9	2224	8.4	2329	8.8	2429	9.1	2526	9.5
1500	2169	8.2	2277	8.6	2379	8.9	2478	9.3	2572	9.7
1600	2226	8.4	2332	8.8	2432	9.1	2528	9.5	2621	9.9
1700	2284	8.6	2388	9.0	2487	9.3	2581	9.7	—	—
1800	2344	8.8	2446	9.2	2543	9.6	2636	9.9	—	—
1900	2405	9.0	2505	9.4	2600	9.8	—	—	—	—
2000	2467	9.3	2566	9.6	2659	10.0	—	—	—	—

High Static 1262-2660 RPM

NOTE: Fan tables include highest gas heat. Utilize static pressure deduction tables for lower gas heat capacities.

# Fan data (cont)

## RGV060 SINGLE PHASE — 5 TON VERTICAL SUPPLY (RPM - BHP)

CFM	AVAILABLE EXTERNAL STATIC PRESSURE (in. wg)									
	0.2		0.4		0.6		0.8		1.0	
	RPM	BHP	RPM	BHP	RPM	BHP	RPM	BHP	RPM	BHP
1500	1478	0.34	1650	0.48	1799	0.62	1932	0.76	2055	0.92
1625	1571	0.41	1735	0.55	1879	0.70	2009	0.86	2129	1.02
1750	1666	0.49	1822	0.64	1962	0.80	2088	0.96	2205	1.13
1875	1761	0.58	1910	0.74	2046	0.91	2169	1.08	2283	1.26
2000	1859	0.68	2001	0.85	2132	1.02	2252	1.21	2363	1.39
2125	1957	0.79	2093	0.97	2218	1.15	2335	1.34	—	—
2250	2056	0.92	2185	1.10	2307	1.30	—	—	—	—
2375	2155	1.06	2279	1.25	—	—	—	—	—	—
2500	2256	1.21	2374	1.41	—	—	—	—	—	—

CFM	AVAILABLE EXTERNAL STATIC PRESSURE (in. wg)									
	1.2		1.4		1.6		1.8		2.0	
	RPM	BHP	RPM	BHP	RPM	BHP	RPM	BHP	RPM	BHP
1500	2169	1.08	2277	1.25	2379	1.43	—	—	—	—
1625	2240	1.19	2345	1.37	—	—	—	—	—	—
1750	2314	1.31	—	—	—	—	—	—	—	—
1875	2389	1.44	—	—	—	—	—	—	—	—
2000	—	—	—	—	—	—	—	—	—	—
2125	—	—	—	—	—	—	—	—	—	—
2250	—	—	—	—	—	—	—	—	—	—
2375	—	—	—	—	—	—	—	—	—	—
2500	—	—	—	—	—	—	—	—	—	—

Standard Static 1478-2150 RPM, 1.06 Max BHP

NOTE: Fan tables include highest gas heat. Utilize static pressure deduction tables for lower gas heat capacities.

Medium Static 1478-2390 RPM, 1.44 Max BHP

## RGV060 SINGLE PHASE – STANDARD STATIC — 5 TON VERTICAL SUPPLY (RPM - VDC)

CFM	AVAILABLE EXTERNAL STATIC PRESSURE (in. wg)									
	0.2		0.4		0.6		0.8		1.0	
	RPM	Vdc	RPM	Vdc	RPM	Vdc	RPM	Vdc	RPM	Vdc
1500	1478	6.9	1650	7.7	1799	8.4	1932	9.0	2055	9.6
1625	1571	7.3	1735	8.1	1879	8.7	2009	9.3	2129	9.9
1750	1666	7.7	1822	8.5	1962	9.1	2088	9.7	—	—
1875	1761	8.2	1910	8.9	2046	9.5	—	—	—	—
2000	1859	8.6	2001	9.3	2132	9.9	—	—	—	—
2125	1957	9.1	2093	9.7	—	—	—	—	—	—
2250	2056	9.6	—	—	—	—	—	—	—	—
2375	—	—	—	—	—	—	—	—	—	—
2500	—	—	—	—	—	—	—	—	—	—

CFM	AVAILABLE EXTERNAL STATIC PRESSURE (in. wg)									
	1.2		1.4		1.6		1.8		2.0	
	RPM	Vdc	RPM	Vdc	RPM	Vdc	RPM	Vdc	RPM	Vdc
1500	—	—	—	—	—	—	—	—	—	—
1625	—	—	—	—	—	—	—	—	—	—
1750	—	—	—	—	—	—	—	—	—	—
1875	—	—	—	—	—	—	—	—	—	—
2000	—	—	—	—	—	—	—	—	—	—
2125	—	—	—	—	—	—	—	—	—	—
2250	—	—	—	—	—	—	—	—	—	—
2375	—	—	—	—	—	—	—	—	—	—
2500	—	—	—	—	—	—	—	—	—	—

Standard Static 1478-2150 RPM

NOTE: Fan tables include highest gas heat. Utilize static pressure deduction tables for lower gas heat capacities.

**RGV060 SINGLE PHASE – MEDIUM STATIC — 5 TON VERTICAL SUPPLY (RPM - VDC)**

CFM	AVAILABLE EXTERNAL STATIC PRESSURE (in. wg)									
	0.2		0.4		0.6		0.8		1.0	
	RPM	Vdc	RPM	Vdc	RPM	Vdc	RPM	Vdc	RPM	Vdc
1500	1478	6.2	1650	6.9	1799	7.5	1932	8.1	2055	8.6
1625	1571	6.6	1735	7.3	1879	7.9	2009	8.4	2129	8.9
1750	1666	7.0	1822	7.6	1962	8.2	2088	8.7	2205	9.2
1875	1761	7.4	1910	8.0	2046	8.6	2169	9.1	2283	9.6
2000	1859	7.8	2001	8.4	2132	8.9	2252	9.4	2363	9.9
2125	1957	8.2	2093	8.8	2218	9.3	2335	9.8	—	—
2250	2056	8.6	2185	9.1	2307	9.7	—	—	—	—
2375	2155	9.0	2279	9.5	—	—	—	—	—	—
2500	2256	9.4	2374	9.9	—	—	—	—	—	—

CFM	AVAILABLE EXTERNAL STATIC PRESSURE (in. wg)									
	1.2		1.4		1.6		1.8		2.0	
	RPM	Vdc	RPM	Vdc	RPM	Vdc	RPM	Vdc	RPM	Vdc
1500	2169	9.1	2277	9.5	2379	10.0	—	—	—	—
1625	2240	9.4	2345	9.8	—	—	—	—	—	—
1750	2314	9.7	—	—	—	—	—	—	—	—
1875	2389	10.0	—	—	—	—	—	—	—	—
2000	—	—	—	—	—	—	—	—	—	—
2125	—	—	—	—	—	—	—	—	—	—
2250	—	—	—	—	—	—	—	—	—	—
2375	—	—	—	—	—	—	—	—	—	—
2500	—	—	—	—	—	—	—	—	—	—

Medium Static 1478-2390 RPM

NOTE: Fan tables include highest gas heat. Utilize static pressure deduction tables for lower gas heat capacities.

# Fan data (cont)

## RGV060 THREE PHASE — 5 TON VERTICAL SUPPLY (RPM - BHP)

CFM	AVAILABLE EXTERNAL STATIC PRESSURE (in. wg)									
	0.2		0.4		0.6		0.8		1.0	
	RPM	BHP	RPM	BHP	RPM	BHP	RPM	BHP	RPM	BHP
1500	1478	0.34	1650	0.48	1798	0.62	1932	0.76	2055	0.92
1625	1571	0.41	1735	0.55	1879	0.70	2009	0.86	2129	1.02
1750	1665	0.49	1822	0.64	1962	0.80	2088	0.96	2205	1.13
1875	1762	0.58	1911	0.74	2046	0.91	2169	1.08	2283	1.26
2000	1859	0.68	2001	0.85	2132	1.02	2252	1.21	2363	1.39
2125	1957	0.79	2093	0.97	2219	1.15	2335	1.34	2444	1.54
2250	2055	0.92	2185	1.10	2307	1.30	2420	1.50	2527	1.70
2375	2156	1.06	2279	1.25	2397	1.45	2507	1.66	2610	1.88
2500	2256	1.21	2374	1.41	2487	1.62	2594	1.84	2695	2.07

CFM	AVAILABLE EXTERNAL STATIC PRESSURE (in. wg)									
	1.2		1.4		1.6		1.8		2.0	
	RPM	BHP	RPM	BHP	RPM	BHP	RPM	BHP	RPM	BHP
1500	2169	1.08	2277	1.25	2379	1.43	2477	1.61	2572	1.80
1625	2240	1.19	2345	1.37	2445	1.55	2541	1.74	2633	1.93
1750	2314	1.31	2417	1.49	2514	1.68	2608	1.88	2698	2.08
1875	2389	1.44	2490	1.63	2586	1.83	2677	2.03	2766	2.24
2000	2467	1.59	2565	1.78	2659	1.99	2749	2.20	2836	2.41
2125	2546	1.74	2643	1.95	2734	2.16	2823	2.38	—	—
2250	2627	1.91	2721	2.13	2812	2.35	—	—	—	—
2375	2708	2.10	2801	2.32	—	—	—	—	—	—
2500	2791	2.30	—	—	—	—	—	—	—	—

Standard Static 1478-2150 RPM, 1.06 Max BHP

Medium Static 1478-2390 RPM, 1.44 Max BHP

High Static 1478-2836 RPM, 2.43 Max BHP

NOTE: Fan tables include highest gas heat. Utilize static pressure deduction tables for lower gas heat capacities.

## RGV060 THREE PHASE – STANDARD STATIC — 5 TON VERTICAL SUPPLY (RPM - VDC)

CFM	AVAILABLE EXTERNAL STATIC PRESSURE (in. wg)									
	0.2		0.4		0.6		0.8		1.0	
	RPM	Vdc	RPM	Vdc	RPM	Vdc	RPM	Vdc	RPM	Vdc
1500	1478	6.9	1650	7.7	1798	8.4	1932	9.0	2055	9.6
1625	1571	7.3	1735	8.1	1879	8.7	2009	9.3	2129	9.9
1750	1665	7.7	1822	8.5	1962	9.1	2088	9.7	—	—
1875	1762	8.2	1911	8.9	2046	9.5	—	—	—	—
2000	1859	8.6	2001	9.3	2132	9.9	—	—	—	—
2125	1957	9.1	2093	9.7	—	—	—	—	—	—
2250	2055	9.6	—	—	—	—	—	—	—	—
2375	—	—	—	—	—	—	—	—	—	—
2500	—	—	—	—	—	—	—	—	—	—

CFM	AVAILABLE EXTERNAL STATIC PRESSURE (in. wg)									
	1.2		1.4		1.6		1.8		2.0	
	RPM	Vdc	RPM	Vdc	RPM	Vdc	RPM	Vdc	RPM	Vdc
1500	—	—	—	—	—	—	—	—	—	—
1625	—	—	—	—	—	—	—	—	—	—
1750	—	—	—	—	—	—	—	—	—	—
1875	—	—	—	—	—	—	—	—	—	—
2000	—	—	—	—	—	—	—	—	—	—
2125	—	—	—	—	—	—	—	—	—	—
2250	—	—	—	—	—	—	—	—	—	—
2375	—	—	—	—	—	—	—	—	—	—
2500	—	—	—	—	—	—	—	—	—	—

Standard Static 1478-2150 RPM

NOTE: Fan tables include highest gas heat. Utilize static pressure deduction tables for lower gas heat capacities.

**RGV060 THREE PHASE – MEDIUM STATIC — 5 TON VERTICAL SUPPLY (RPM - VDC)**

CFM	AVAILABLE EXTERNAL STATIC PRESSURE (in. wg)									
	0.2		0.4		0.6		0.8		1.0	
	RPM	Vdc	RPM	Vdc	RPM	Vdc	RPM	Vdc	RPM	Vdc
1500	1478	6.2	1650	6.9	1798	7.5	1932	8.1	2055	8.6
1625	1571	6.6	1735	7.3	1879	7.9	2009	8.4	2129	8.9
1750	1665	7.0	1822	7.6	1962	8.2	2088	8.7	2205	9.2
1875	1762	7.4	1911	8.0	2046	8.6	2169	9.1	2283	9.6
2000	1859	7.8	2001	8.4	2132	8.9	2252	9.4	2363	9.9
2125	1957	8.2	2093	8.8	2219	9.3	2335	9.8	—	—
2250	2055	8.6	2185	9.1	2307	9.7	—	—	—	—
2375	2156	9.0	2279	9.5	—	—	—	—	—	—
2500	2256	9.4	2374	9.9	—	—	—	—	—	—

CFM	AVAILABLE EXTERNAL STATIC PRESSURE (in. wg)									
	1.2		1.4		1.6		1.8		2.0	
	RPM	Vdc	RPM	Vdc	RPM	Vdc	RPM	Vdc	RPM	Vdc
1500	2169	9.1	2277	9.5	2379	10.0	—	—	—	—
1625	2240	9.4	2345	9.8	—	—	—	—	—	—
1750	2314	9.7	—	—	—	—	—	—	—	—
1875	2389	10.0	—	—	—	—	—	—	—	—
2000	—	—	—	—	—	—	—	—	—	—
2125	—	—	—	—	—	—	—	—	—	—
2250	—	—	—	—	—	—	—	—	—	—
2375	—	—	—	—	—	—	—	—	—	—
2500	—	—	—	—	—	—	—	—	—	—

Medium Static 1478-2390 RPM

NOTE: Fan tables include highest gas heat. Utilize static pressure deduction tables for lower gas heat capacities.

**RGV060 THREE PHASE – HIGH STATIC — 5 TON VERTICAL SUPPLY (RPM - VDC)**

CFM	AVAILABLE EXTERNAL STATIC PRESSURE (in. wg)									
	0.2		0.4		0.6		0.8		1.0	
	RPM	Vdc	RPM	Vdc	RPM	Vdc	RPM	Vdc	RPM	Vdc
1500	1478	5.2	1650	5.8	1798	6.3	1932	6.8	2055	7.2
1625	1571	5.5	1735	6.1	1879	6.6	2009	7.1	2129	7.5
1750	1665	5.9	1822	6.4	1962	6.9	2088	7.4	2205	7.8
1875	1762	6.2	1911	6.7	2046	7.2	2169	7.6	2283	8.1
2000	1859	6.6	2001	7.1	2132	7.5	2252	7.9	2363	8.3
2125	1957	6.9	2093	7.4	2219	7.8	2335	8.2	2444	8.6
2250	2055	7.2	2185	7.7	2307	8.1	2420	8.5	2527	8.9
2375	2156	7.6	2279	8.0	2397	8.5	2507	8.8	2610	9.2
2500	2256	8.0	2374	8.4	2487	8.8	2594	9.1	2695	9.5

CFM	AVAILABLE EXTERNAL STATIC PRESSURE (in. wg)									
	1.2		1.4		1.6		1.8		2.0	
	RPM	Vdc	RPM	Vdc	RPM	Vdc	RPM	Vdc	RPM	Vdc
1500	2169	7.6	2277	8.0	2379	8.4	2477	8.7	2572	9.1
1625	2240	7.9	2345	8.3	2445	8.6	2541	9.0	2633	9.3
1750	2314	8.2	2417	8.5	2514	8.9	2608	9.2	2698	9.5
1875	2389	8.4	2490	8.8	2586	9.1	2677	9.4	2766	9.8
2000	2467	8.7	2565	9.0	2659	9.4	2749	9.7	2836	10.0
2125	2546	9.0	2643	9.3	2734	9.6	2823	10.0	—	—
2250	2627	9.3	2721	9.6	2812	9.9	—	—	—	—
2375	2708	9.5	2801	9.9	—	—	—	—	—	—
2500	2791	9.8	—	—	—	—	—	—	—	—

High Static 1478-2836 RPM

NOTE: Fan tables include highest gas heat. Utilize static pressure deduction tables for lower gas heat capacities.

# Fan data (cont)

## RGV072 THREE PHASE — 6 TON VERTICAL SUPPLY (RPM - BHP)

CFM	AVAILABLE EXTERNAL STATIC PRESSURE (in. wg)									
	0.2		0.4		0.6		0.8		1.0	
	RPM	BHP	RPM	BHP	RPM	BHP	RPM	BHP	RPM	BHP
1800	1596	0.43	1749	0.56	1889	0.71	2015	0.86	2131	1.02
1950	1704	0.52	1847	0.67	1981	0.82	2104	0.98	2217	1.15
2100	1814	0.63	1948	0.78	2075	0.94	2194	1.12	2305	1.29
2250	1924	0.75	2050	0.91	2172	1.08	2286	1.26	2394	1.45
2400	2037	0.89	2155	1.06	2270	1.24	2381	1.43	2485	1.62
2550	2150	1.05	2261	1.22	2370	1.41	2476	1.61	2578	1.81
2700	2265	1.23	2368	1.40	2472	1.60	2574	1.80	2672	2.02
2850	2379	1.43	2477	1.61	2576	1.81	2674	2.02	2768	2.24
3000	2495	1.64	2587	1.83	2681	2.04	2775	2.26	—	—

CFM	AVAILABLE EXTERNAL STATIC PRESSURE (in. wg)									
	1.2		1.4		1.6		1.8		2.0	
	RPM	BHP	RPM	BHP	RPM	BHP	RPM	BHP	RPM	BHP
1800	2239	1.19	2340	1.35	2436	1.53	2528	1.71	2615	1.89
1950	2323	1.32	2422	1.50	2516	1.68	2605	1.87	2691	2.06
2100	2408	1.47	2505	1.66	2597	1.85	2685	2.04	2770	2.25
2250	2495	1.64	2590	1.84	2681	2.04	2767	2.24	—	—
2400	2584	1.82	2677	2.03	2766	2.24	—	—	—	—
2550	2674	2.02	2766	2.24	—	—	—	—	—	—
2700	2766	2.24	—	—	—	—	—	—	—	—
2850	—	—	—	—	—	—	—	—	—	—
3000	—	—	—	—	—	—	—	—	—	—

Standard Static 1596-2300 RPM, 1.31 Max BHP

Medium Static 1596-2530 RPM, 1.76 Max BHP

High Static 1596-2836 RPM, 2.43 Max BHP

NOTE: Fan tables include highest gas heat. Utilize static pressure deduction tables for lower gas heat capacities.

## RGV072 THREE PHASE – STANDARD STATIC — 6 TON VERTICAL SUPPLY (RPM - VDC)

CFM	AVAILABLE EXTERNAL STATIC PRESSURE (in. wg)									
	0.2		0.4		0.6		0.8		1.0	
	RPM	Vdc	RPM	Vdc	RPM	Vdc	RPM	Vdc	RPM	Vdc
1800	1596	6.9	1749	7.6	1889	8.2	2015	8.8	2131	9.3
1950	1704	7.4	1847	8.0	1981	8.6	2104	9.1	2217	9.6
2100	1814	7.9	1948	8.5	2075	9.0	2194	9.5	—	—
2250	1925	8.4	2050	8.9	2172	9.4	2286	9.9	—	—
2400	2037	8.9	2154	9.4	2270	9.9	—	—	—	—
2550	2150	9.3	2261	9.8	—	—	—	—	—	—
2700	2265	9.8	—	—	—	—	—	—	—	—
2850	—	—	—	—	—	—	—	—	—	—
3000	—	—	—	—	—	—	—	—	—	—

CFM	AVAILABLE EXTERNAL STATIC PRESSURE (in. wg)									
	1.2		1.4		1.6		1.8		2.0	
	RPM	Vdc	RPM	Vdc	RPM	Vdc	RPM	Vdc	RPM	Vdc
1800	2239	9.7	—	—	—	—	—	—	—	—
1950	—	—	—	—	—	—	—	—	—	—
2100	—	—	—	—	—	—	—	—	—	—
2250	—	—	—	—	—	—	—	—	—	—
2400	—	—	—	—	—	—	—	—	—	—
2550	—	—	—	—	—	—	—	—	—	—
2700	—	—	—	—	—	—	—	—	—	—
2850	—	—	—	—	—	—	—	—	—	—
3000	—	—	—	—	—	—	—	—	—	—

Standard Static 1596-2300 RPM

NOTE: Fan tables include highest gas heat. Utilize static pressure deduction tables for lower gas heat capacities.

**RGV072 THREE PHASE – MEDIUM STATIC — 6 TON VERTICAL SUPPLY (RPM - VDC)**

CFM	AVAILABLE EXTERNAL STATIC PRESSURE (in. wg)									
	0.2		0.4		0.6		0.8		1.0	
	RPM	Vdc	RPM	Vdc	RPM	Vdc	RPM	Vdc	RPM	Vdc
1800	1596	6.3	1749	6.9	1889	7.5	2015	8.0	2131	8.4
1950	1704	6.7	1847	7.3	1981	7.8	2104	8.3	2217	8.8
2100	1814	7.2	1948	7.7	2075	8.2	2194	8.7	2305	9.1
2250	1925	7.6	2050	8.1	2172	8.6	2286	9.0	2394	9.5
2400	2037	8.1	2154	8.5	2270	9.0	2381	9.4	2485	9.8
2550	2150	8.5	2261	8.9	2370	9.4	2477	9.8	—	—
2700	2265	9.0	2368	9.4	2472	9.8	—	—	—	—
2850	2379	9.4	2477	9.8	—	—	—	—	—	—
3000	2495	9.9	—	—	—	—	—	—	—	—

CFM	AVAILABLE EXTERNAL STATIC PRESSURE (in. wg)									
	1.2		1.4		1.6		1.8		2.0	
	RPM	Vdc	RPM	Vdc	RPM	Vdc	RPM	Vdc	RPM	Vdc
1800	2239	8.8	2340	9.2	2436	9.6	2527	10.0	—	—
1950	2323	9.2	2422	9.6	2516	9.9	—	—	—	—
2100	2408	9.5	2505	9.9	—	—	—	—	—	—
2250	2495	9.9	—	—	—	—	—	—	—	—
2400	—	—	—	—	—	—	—	—	—	—
2550	—	—	—	—	—	—	—	—	—	—
2700	—	—	—	—	—	—	—	—	—	—
2850	—	—	—	—	—	—	—	—	—	—
3000	—	—	—	—	—	—	—	—	—	—

Medium Static 1596-2530 RPM

NOTE: Fan tables include highest gas heat. Utilize static pressure deduction tables for lower gas heat capacities.

**RGV072 THREE PHASE – HIGH STATIC — 6 TON VERTICAL SUPPLY (RPM - VDC)**

CFM	AVAILABLE EXTERNAL STATIC PRESSURE (in. wg)									
	0.2		0.4		0.6		0.8		1.0	
	RPM	Vdc	RPM	Vdc	RPM	Vdc	RPM	Vdc	RPM	Vdc
1800	1596	5.6	1749	6.2	1889	6.7	2015	7.1	2131	7.5
1950	1704	6.0	1847	6.5	1981	7.0	2104	7.4	2217	7.8
2100	1814	6.4	1948	6.9	2075	7.3	2194	7.7	2305	8.1
2250	1925	6.8	2050	7.2	2172	7.7	2286	8.1	2394	8.4
2400	2037	7.2	2154	7.6	2270	8.0	2381	8.4	2485	8.8
2550	2150	7.6	2261	8.0	2370	8.4	2477	8.7	2578	9.1
2700	2265	8.0	2368	8.3	2472	8.7	2574	9.1	2672	9.4
2850	2379	8.4	2477	8.7	2576	9.1	2674	9.4	2768	9.8
3000	2495	8.8	2587	9.1	2681	9.5	2775	9.8	—	—

CFM	AVAILABLE EXTERNAL STATIC PRESSURE (in. wg)									
	1.2		1.4		1.6		1.8		2.0	
	RPM	Vdc	RPM	Vdc	RPM	Vdc	RPM	Vdc	RPM	Vdc
1800	2239	7.9	2340	8.3	2436	8.6	2527	8.9	2615	9.2
1950	2323	8.2	2422	8.5	2516	8.9	2605	9.2	2691	9.5
2100	2408	8.5	2505	8.8	2597	9.2	2685	9.5	2770	9.8
2250	2495	8.8	2590	9.1	2681	9.5	2767	9.8	—	—
2400	2584	9.1	2677	9.4	2766	9.8	—	—	—	—
2550	2674	9.4	2766	9.8	—	—	—	—	—	—
2700	2766	9.8	—	—	—	—	—	—	—	—
2850	—	—	—	—	—	—	—	—	—	—
3000	—	—	—	—	—	—	—	—	—	—

High Static 1596-2836 RPM

NOTE: Fan tables include highest gas heat. Utilize static pressure deduction tables for lower gas heat capacities.

# Fan data (cont)

## RGV036 SINGLE PHASE — 3 TON HORIZONTAL SUPPLY (RPM - BHP)

CFM	AVAILABLE EXTERNAL STATIC PRESSURE (in. wg)									
	0.2		0.4		0.6		0.8		1.0	
	RPM	BHP	RPM	BHP	RPM	BHP	RPM	BHP	RPM	BHP
900	1079	0.09	1315	0.16	1510	0.24	1679	0.33	1830	0.43
975	1126	0.10	1355	0.17	1546	0.26	1713	0.35	1863	0.45
1050	1175	0.11	1396	0.19	1584	0.28	1749	0.37	1897	0.48
1125	1226	0.13	1438	0.21	1622	0.30	1785	0.40	1932	0.50
1200	1278	0.15	1482	0.23	1662	0.32	1822	0.42	1968	0.53
1275	1331	0.16	1528	0.25	1703	0.34	1861	0.45	2004	0.56
1350	1386	0.19	1575	0.27	1746	0.37	1900	0.48	2042	0.59
1425	1441	0.21	1623	0.30	1789	0.40	1941	0.51	2080	0.63
1500	1498	0.23	1672	0.33	1834	0.43	1982	0.54	2119	0.66

CFM	AVAILABLE EXTERNAL STATIC PRESSURE (in. wg)									
	1.2		1.4		1.6		1.8		2.0	
	RPM	BHP	RPM	BHP	RPM	BHP	RPM	BHP	RPM	BHP
900	1968	0.53	2096	0.64	2215	0.76	2328	0.88	2434	1.00
975	2000	0.56	2127	0.67	2246	0.79	2358	0.91	2464	1.04
1050	2033	0.59	2159	0.70	2277	0.82	2389	0.95	—	—
1125	2067	0.61	2192	0.73	2309	0.86	2420	0.99	—	—
1200	2101	0.65	2225	0.77	2342	0.89	2452	1.03	—	—
1275	2136	0.68	2260	0.80	2376	0.93	2485	1.07	—	—
1350	2172	0.71	2295	0.84	2410	0.97	—	—	—	—
1425	2209	0.75	2330	0.88	2445	1.02	—	—	—	—
1500	2247	0.79	2367	0.92	2480	1.06	—	—	—	—

Standard Static 1079-1890 RPM, 0.44 Max BHP

High Static 1079-2490 RPM, 1.07 Max BHP

Medium Static 1079-2190 RPM, 0.71 Max BHP

NOTE: Fan tables include highest gas heat. Utilize static pressure deduction tables for lower gas heat capacities.

## RGV036 SINGLE PHASE – STANDARD STATIC — 3 TON HORIZONTAL SUPPLY (RPM - VDC)

CFM	AVAILABLE EXTERNAL STATIC PRESSURE (in. wg)									
	0.2		0.4		0.6		0.8		1.0	
	RPM	Vdc	RPM	Vdc	RPM	Vdc	RPM	Vdc	RPM	Vdc
900	1079	5.7	1315	7.0	1510	8.0	1679	8.9	1830	9.7
975	1126	6.0	1355	7.2	1546	8.2	1713	9.1	—	—
1050	1175	6.2	1396	7.4	1584	8.4	1749	9.3	—	—
1125	1226	6.5	1438	7.6	1622	8.6	1785	9.4	—	—
1200	1278	6.8	1482	7.8	1662	8.8	1822	9.6	—	—
1275	1331	7.0	1528	8.1	1703	9.0	—	—	—	—
1350	1386	7.3	1575	8.3	1746	9.2	—	—	—	—
1425	1441	7.6	1623	8.6	1789	9.5	—	—	—	—
1500	1498	7.9	1672	8.8	1834	9.7	—	—	—	—

CFM	AVAILABLE EXTERNAL STATIC PRESSURE (in. wg)									
	1.2		1.4		1.6		1.8		2.0	
	RPM	Vdc	RPM	Vdc	RPM	Vdc	RPM	Vdc	RPM	Vdc
900	—	—	—	—	—	—	—	—	—	—
975	—	—	—	—	—	—	—	—	—	—
1050	—	—	—	—	—	—	—	—	—	—
1125	—	—	—	—	—	—	—	—	—	—
1200	—	—	—	—	—	—	—	—	—	—
1275	—	—	—	—	—	—	—	—	—	—
1350	—	—	—	—	—	—	—	—	—	—
1425	—	—	—	—	—	—	—	—	—	—
1500	—	—	—	—	—	—	—	—	—	—

Standard Static 1079-1890 RPM

NOTE: Fan tables include highest gas heat. Utilize static pressure deduction tables for lower gas heat capacities.

**RGV036 SINGLE PHASE – MEDIUM STATIC — 3 TON HORIZONTAL SUPPLY (RPM - VDC)**

CFM	AVAILABLE EXTERNAL STATIC PRESSURE (in. wg)									
	0.2		0.4		0.6		0.8		1.0	
	RPM	Vdc	RPM	Vdc	RPM	Vdc	RPM	Vdc	RPM	Vdc
900	1079	4.9	1315	6.0	1510	6.9	1679	7.7	1830	8.4
975	1126	5.1	1355	6.2	1546	7.1	1713	7.8	1863	8.5
1050	1175	5.4	1396	6.4	1584	7.2	1749	8.0	1897	8.7
1125	1226	5.6	1438	6.6	1622	7.4	1785	8.2	1932	8.8
1200	1278	5.8	1482	6.8	1662	7.6	1822	8.3	1968	9.0
1275	1331	6.1	1528	7.0	1703	7.8	1861	8.5	2004	9.2
1350	1386	6.3	1575	7.2	1746	8.0	1900	8.7	2042	9.3
1425	1441	6.6	1623	7.4	1789	8.2	1941	8.9	2080	9.5
1500	1498	6.8	1672	7.6	1834	8.4	1982	9.1	2119	9.7

CFM	AVAILABLE EXTERNAL STATIC PRESSURE (in. wg)									
	1.2		1.4		1.6		1.8		2.0	
	RPM	Vdc	RPM	Vdc	RPM	Vdc	RPM	Vdc	RPM	Vdc
900	1968	9.0	2096	9.6	—	—	—	—	—	—
975	2000	9.1	2127	9.7	—	—	—	—	—	—
1050	2033	9.3	2159	9.9	—	—	—	—	—	—
1125	2067	9.4	—	—	—	—	—	—	—	—
1200	2101	9.6	—	—	—	—	—	—	—	—
1275	2136	9.8	—	—	—	—	—	—	—	—
1350	2172	9.9	—	—	—	—	—	—	—	—
1425	—	—	—	—	—	—	—	—	—	—
1500	—	—	—	—	—	—	—	—	—	—

Medium Static 1079-2190 RPM

NOTE: Fan tables include highest gas heat. Utilize static pressure deduction tables for lower gas heat capacities.

**RGV036 SINGLE PHASE – HIGH STATIC — 3 TON HORIZONTAL SUPPLY (RPM - VDC)**

CFM	AVAILABLE EXTERNAL STATIC PRESSURE (in. wg)									
	0.2		0.4		0.6		0.8		1.0	
	RPM	Vdc	RPM	Vdc	RPM	Vdc	RPM	Vdc	RPM	Vdc
900	1079	4.3	1315	5.3	1510	6.1	1679	6.7	1830	7.3
975	1126	4.5	1355	5.4	1546	6.2	1713	6.9	1863	7.5
1050	1175	4.7	1396	5.6	1584	6.4	1749	7.0	1897	7.6
1125	1226	4.9	1438	5.8	1622	6.5	1785	7.2	1932	7.8
1200	1278	5.1	1482	6.0	1662	6.7	1822	7.3	1968	7.9
1275	1331	5.3	1528	6.1	1703	6.8	1861	7.5	2004	8.0
1350	1386	5.6	1575	6.3	1746	7.0	1900	7.6	2042	8.2
1425	1441	5.8	1623	6.5	1789	7.2	1941	7.8	2080	8.4
1500	1498	6.0	1672	6.7	1834	7.4	1982	8.0	2119	8.5

CFM	AVAILABLE EXTERNAL STATIC PRESSURE (in. wg)									
	1.2		1.4		1.6		1.8		2.0	
	RPM	Vdc	RPM	Vdc	RPM	Vdc	RPM	Vdc	RPM	Vdc
900	1968	7.9	2096	8.4	2215	8.9	2328	9.3	2434	9.8
975	2000	8.0	2127	8.5	2246	9.0	2358	9.5	2464	9.9
1050	2033	8.2	2159	8.7	2277	9.1	2389	9.6	—	—
1125	2067	8.3	2192	8.8	2309	9.3	2420	9.7	—	—
1200	2101	8.4	2225	8.9	2342	9.4	2452	9.8	—	—
1275	2136	8.6	2260	9.1	2376	9.5	2485	10.0	—	—
1350	2172	8.7	2295	9.2	2410	9.7	—	—	—	—
1425	2209	8.9	2330	9.4	2445	9.8	—	—	—	—
1500	2247	9.0	2367	9.5	2480	10.0	—	—	—	—

High Static 1079-2490 RPM

NOTE: Fan tables include highest gas heat. Utilize static pressure deduction tables for lower gas heat capacities.

# Fan data (cont)

## RGV036 THREE PHASE — 3 TON HORIZONTAL SUPPLY (RPM - BHP)

CFM	AVAILABLE EXTERNAL STATIC PRESSURE (in. wg)									
	0.2		0.4		0.6		0.8		1.0	
	RPM	BHP	RPM	BHP	RPM	BHP	RPM	BHP	RPM	BHP
900	1079	0.09	1315	0.16	1510	0.24	1679	0.33	1830	0.43
975	1126	0.10	1355	0.17	1546	0.26	1713	0.35	1863	0.45
1050	1175	0.11	1396	0.19	1584	0.28	1749	0.37	1897	0.48
1125	1226	0.13	1438	0.21	1622	0.30	1785	0.40	1932	0.50
1200	1278	0.15	1482	0.23	1662	0.32	1822	0.42	1968	0.53
1275	1331	0.16	1528	0.25	1703	0.34	1861	0.45	2004	0.56
1350	1386	0.19	1575	0.27	1746	0.37	1900	0.48	2042	0.59
1425	1441	0.21	1623	0.30	1789	0.40	1941	0.51	2080	0.63
1500	1498	0.23	1672	0.33	1834	0.43	1982	0.54	2119	0.66

CFM	AVAILABLE EXTERNAL STATIC PRESSURE (in. wg)									
	1.2		1.4		1.6		1.8		2.0	
	RPM	BHP	RPM	BHP	RPM	BHP	RPM	BHP	RPM	BHP
900	1968	0.53	2096	0.64	2215	0.76	2328	0.88	2434	1.00
975	2000	0.56	2127	0.67	2246	0.79	2358	0.91	2464	1.04
1050	2033	0.59	2159	0.70	2277	0.82	2389	0.95	—	—
1125	2067	0.61	2192	0.73	2309	0.86	2420	0.99	—	—
1200	2101	0.65	2225	0.77	2342	0.89	2452	1.03	—	—
1275	2136	0.68	2260	0.80	2376	0.93	2485	1.07	—	—
1350	2172	0.71	2295	0.84	2410	0.97	—	—	—	—
1425	2209	0.75	2330	0.88	2445	1.02	—	—	—	—
1500	2247	0.79	2367	0.92	2480	1.06	—	—	—	—

Standard Static 1079-1890 RPM, 0.44 Max BHP

High Static 1079-2490 RPM, 1.07 Max BHP

Medium Static 1079-2190 RPM, 0.71 Max BHP

NOTE: Fan tables include highest gas heat. Utilize static pressure deduction tables for lower gas heat capacities.

## RGV036 THREE PHASE – STANDARD STATIC — 3 TON HORIZONTAL SUPPLY (RPM - VDC)

CFM	AVAILABLE EXTERNAL STATIC PRESSURE (in. wg)									
	0.2		0.4		0.6		0.8		1.0	
	RPM	Vdc	RPM	Vdc	RPM	Vdc	RPM	Vdc	RPM	Vdc
900	1079	5.7	1315	7.0	1510	8.0	1679	8.9	1830	9.7
975	1126	6.0	1355	7.2	1546	8.2	1713	9.1	—	—
1050	1175	6.2	1396	7.4	1584	8.4	1749	9.3	—	—
1125	1226	6.5	1438	7.6	1622	8.6	1785	9.4	—	—
1200	1278	6.8	1482	7.8	1662	8.8	1822	9.6	—	—
1275	1331	7.0	1528	8.1	1703	9.0	—	—	—	—
1350	1386	7.3	1575	8.3	1746	9.2	—	—	—	—
1425	1441	7.6	1623	8.6	1789	9.5	—	—	—	—
1500	1498	7.9	1672	8.8	1834	9.7	—	—	—	—

CFM	AVAILABLE EXTERNAL STATIC PRESSURE (in. wg)									
	1.2		1.4		1.6		1.8		2.0	
	RPM	Vdc	RPM	Vdc	RPM	Vdc	RPM	Vdc	RPM	Vdc
900	—	—	—	—	—	—	—	—	—	—
975	—	—	—	—	—	—	—	—	—	—
1050	—	—	—	—	—	—	—	—	—	—
1125	—	—	—	—	—	—	—	—	—	—
1200	—	—	—	—	—	—	—	—	—	—
1275	—	—	—	—	—	—	—	—	—	—
1350	—	—	—	—	—	—	—	—	—	—
1425	—	—	—	—	—	—	—	—	—	—
1500	—	—	—	—	—	—	—	—	—	—

Standard Static 1079-1890 RPM

NOTE: Fan tables include highest gas heat. Utilize static pressure deduction tables for lower gas heat capacities.

**RGV036 THREE PHASE – MEDIUM STATIC — 3 TON HORIZONTAL SUPPLY (RPM - VDC)**

CFM	AVAILABLE EXTERNAL STATIC PRESSURE (in. wg)									
	0.2		0.4		0.6		0.8		1.0	
	RPM	Vdc	RPM	Vdc	RPM	Vdc	RPM	Vdc	RPM	Vdc
900	1079	4.9	1315	6.0	1510	6.9	1679	7.7	1830	8.4
975	1126	5.1	1355	6.2	1546	7.1	1713	7.8	1863	8.5
1050	1175	5.4	1396	6.4	1584	7.2	1749	8.0	1897	8.7
1125	1226	5.6	1438	6.6	1622	7.4	1785	8.2	1932	8.8
1200	1278	5.8	1482	6.8	1662	7.6	1822	8.3	1968	9.0
1275	1331	6.1	1528	7.0	1703	7.8	1861	8.5	2004	9.2
1350	1386	6.3	1575	7.2	1746	8.0	1900	8.7	2042	9.3
1425	1441	6.6	1623	7.4	1789	8.2	1941	8.9	2080	9.5
1500	1498	6.8	1672	7.6	1834	8.4	1982	9.1	2119	9.7

CFM	AVAILABLE EXTERNAL STATIC PRESSURE (in. wg)									
	1.2		1.4		1.6		1.8		2.0	
	RPM	Vdc	RPM	Vdc	RPM	Vdc	RPM	Vdc	RPM	Vdc
900	1968	9.0	2096	9.6	—	—	—	—	—	—
975	2000	9.1	2127	9.7	—	—	—	—	—	—
1050	2033	9.3	2159	9.9	—	—	—	—	—	—
1125	2067	9.4	—	—	—	—	—	—	—	—
1200	2101	9.6	—	—	—	—	—	—	—	—
1275	2136	9.8	—	—	—	—	—	—	—	—
1350	2172	9.9	—	—	—	—	—	—	—	—
1425	—	—	—	—	—	—	—	—	—	—
1500	—	—	—	—	—	—	—	—	—	—

Medium Static 1079-2190 RPM

NOTE: Fan tables include highest gas heat. Utilize static pressure deduction tables for lower gas heat capacities.

**RGV036 THREE PHASE – HIGH STATIC — 3 TON HORIZONTAL SUPPLY (RPM - VDC)**

CFM	AVAILABLE EXTERNAL STATIC PRESSURE (in. wg)									
	0.2		0.4		0.6		0.8		1.0	
	RPM	Vdc	RPM	Vdc	RPM	Vdc	RPM	Vdc	RPM	Vdc
900	1079	4.3	1315	5.3	1510	6.1	1679	6.7	1830	7.3
975	1126	4.5	1355	5.4	1546	6.2	1713	6.9	1863	7.5
1050	1175	4.7	1396	5.6	1584	6.4	1749	7.0	1897	7.6
1125	1226	4.9	1438	5.8	1622	6.5	1785	7.2	1932	7.8
1200	1278	5.1	1482	6.0	1662	6.7	1822	7.3	1968	7.9
1275	1331	5.3	1528	6.1	1703	6.8	1861	7.5	2004	8.0
1350	1386	5.6	1575	6.3	1746	7.0	1900	7.6	2042	8.2
1425	1441	5.8	1623	6.5	1789	7.2	1941	7.8	2080	8.4
1500	1498	6.0	1672	6.7	1834	7.4	1982	8.0	2119	8.5

CFM	AVAILABLE EXTERNAL STATIC PRESSURE (in. wg)									
	1.2		1.4		1.6		1.8		2.0	
	RPM	Vdc	RPM	Vdc	RPM	Vdc	RPM	Vdc	RPM	Vdc
900	1968	7.9	2096	8.4	2215	8.9	2328	9.3	2434	9.8
975	2000	8.0	2127	8.5	2246	9.0	2358	9.5	2464	9.9
1050	2033	8.2	2159	8.7	2277	9.1	2389	9.6	—	—
1125	2067	8.3	2192	8.8	2309	9.3	2420	9.7	—	—
1200	2101	8.4	2225	8.9	2342	9.4	2452	9.8	—	—
1275	2136	8.6	2260	9.1	2376	9.5	2485	10.0	—	—
1350	2172	8.7	2295	9.2	2410	9.7	—	—	—	—
1425	2209	8.9	2330	9.4	2445	9.8	—	—	—	—
1500	2247	9.0	2367	9.5	2480	10.0	—	—	—	—

High Static 1079-2490 RPM

NOTE: Fan tables include highest gas heat. Utilize static pressure deduction tables for lower gas heat capacities.

# Fan data (cont)

## RGV048 SINGLE PHASE — 4 TON HORIZONTAL SUPPLY (RPM - BHP)

CFM	AVAILABLE EXTERNAL STATIC PRESSURE (in. wg)									
	0.2		0.4		0.6		0.8		1.0	
	RPM	BHP	RPM	BHP	RPM	BHP	RPM	BHP	RPM	BHP
1200	1217	0.19	1411	0.30	1576	0.42	1722	0.55	1855	0.68
1300	1283	0.23	1470	0.34	1631	0.46	1774	0.60	1904	0.74
1400	1351	0.26	1531	0.38	1688	0.51	1827	0.65	1955	0.80
1500	1420	0.31	1593	0.43	1746	0.57	1883	0.71	2008	0.86
1600	1491	0.35	1657	0.48	1805	0.63	1939	0.78	2062	0.93
1700	1563	0.41	1722	0.54	1866	0.69	1997	0.85	2118	1.01
1800	1635	0.46	1789	0.61	1928	0.76	2056	0.92	2174	1.09
1900	1709	0.53	1856	0.68	1991	0.84	2116	1.01	2232	1.18
2000	1784	0.60	1925	0.76	2056	0.92	2178	1.10	2291	1.28

CFM	AVAILABLE EXTERNAL STATIC PRESSURE (in. wg)									
	1.2		1.4		1.6		1.8		2.0	
	RPM	BHP	RPM	BHP	RPM	BHP	RPM	BHP	RPM	BHP
1200	1979	0.83	2094	0.98	2204	1.15	2308	1.32	2409	1.50
1300	2025	0.89	2138	1.05	2246	1.21	2349	1.39	2447	1.57
1400	2074	0.95	2185	1.11	2291	1.28	2391	1.46	—	—
1500	2124	1.02	2234	1.19	2338	1.36	2436	1.54	—	—
1600	2176	1.10	2284	1.27	2386	1.45	—	—	—	—
1700	2230	1.18	2336	1.36	2436	1.54	—	—	—	—
1800	2285	1.27	2389	1.45	—	—	—	—	—	—
1900	2341	1.36	2444	1.55	—	—	—	—	—	—
2000	2398	1.46	—	—	—	—	—	—	—	—

NOTE: Fan tables include highest gas heat. Utilize static pressure deduction tables for lower gas heat capacities.

- Standard Static 1217-1990 RPM, 0.72 Max BHP
- Medium Static 1217-2170 RPM, 1.06 Max BHP
- High Static 1217-2460 RPM, 1.53 Max BHP

## RGV048 SINGLE PHASE – STANDARD STATIC — 4 TON HORIZONTAL SUPPLY (RPM - VDC)

CFM	AVAILABLE EXTERNAL STATIC PRESSURE (in. wg)									
	0.2		0.4		0.6		0.8		1.0	
	RPM	Vdc	RPM	Vdc	RPM	Vdc	RPM	Vdc	RPM	Vdc
1200	1217	6.4	1411	7.4	1576	8.3	1722	9.1	1855	9.8
1300	1283	6.8	1470	7.7	1631	8.6	1774	9.3	—	—
1400	1351	7.1	1531	8.1	1688	8.9	1827	9.6	—	—
1500	1420	7.5	1593	8.4	1746	9.2	1883	9.9	—	—
1600	1491	7.8	1657	8.7	1805	9.5	—	—	—	—
1700	1563	8.2	1722	9.1	1866	9.8	—	—	—	—
1800	1635	8.6	1789	9.4	—	—	—	—	—	—
1900	1709	9.0	1856	9.8	—	—	—	—	—	—
2000	1784	9.4	—	—	—	—	—	—	—	—

CFM	AVAILABLE EXTERNAL STATIC PRESSURE (in. wg)									
	1.2		1.4		1.6		1.8		2.0	
	RPM	Vdc	RPM	Vdc	RPM	Vdc	RPM	Vdc	RPM	Vdc
1200	—	—	—	—	—	—	—	—	—	—
1300	—	—	—	—	—	—	—	—	—	—
1400	—	—	—	—	—	—	—	—	—	—
1500	—	—	—	—	—	—	—	—	—	—
1600	—	—	—	—	—	—	—	—	—	—
1700	—	—	—	—	—	—	—	—	—	—
1800	—	—	—	—	—	—	—	—	—	—
1900	—	—	—	—	—	—	—	—	—	—
2000	—	—	—	—	—	—	—	—	—	—

NOTE: Fan tables include highest gas heat. Utilize static pressure deduction tables for lower gas heat capacities.

- Standard Static 1217-1990 RPM

**RGV048 SINGLE PHASE – MEDIUM STATIC — 4 TON HORIZONTAL SUPPLY (RPM - VDC)**

CFM	AVAILABLE EXTERNAL STATIC PRESSURE (in. wg)									
	0.2		0.4		0.6		0.8		1.0	
	RPM	Vdc	RPM	Vdc	RPM	Vdc	RPM	Vdc	RPM	Vdc
1200	1217	5.6	1411	6.5	1576	7.3	1722	7.9	1855	8.5
1300	1283	5.9	1470	6.8	1631	7.5	1774	8.2	1904	8.8
1400	1351	6.2	1531	7.1	1688	7.8	1827	8.4	1955	9.0
1500	1420	6.5	1593	7.3	1746	8.0	1883	8.7	2008	9.3
1600	1491	6.9	1657	7.6	1805	8.3	1939	8.9	2062	9.5
1700	1563	7.2	1722	7.9	1866	8.6	1997	9.2	2118	9.8
1800	1635	7.5	1789	8.2	1928	8.9	2056	9.5	—	—
1900	1709	7.9	1856	8.6	1991	9.2	2116	9.8	—	—
2000	1784	8.2	1925	8.9	2056	9.5	—	—	—	—

CFM	AVAILABLE EXTERNAL STATIC PRESSURE (in. wg)									
	1.2		1.4		1.6		1.8		2.0	
	RPM	Vdc	RPM	Vdc	RPM	Vdc	RPM	Vdc	RPM	Vdc
1200	1979	9.1	2094	9.6	—	—	—	—	—	—
1300	2025	9.3	2138	9.9	—	—	—	—	—	—
1400	2074	9.6	—	—	—	—	—	—	—	—
1500	2124	9.8	—	—	—	—	—	—	—	—
1600	—	—	—	—	—	—	—	—	—	—
1700	—	—	—	—	—	—	—	—	—	—
1800	—	—	—	—	—	—	—	—	—	—
1900	—	—	—	—	—	—	—	—	—	—
2000	—	—	—	—	—	—	—	—	—	—

NOTE: Fan tables include highest gas heat. Utilize static pressure deduction tables for lower gas heat capacities.

Medium Static 1217-2170 RPM

**RGV048 SINGLE PHASE – HIGH STATIC — 4 TON HORIZONTAL SUPPLY (RPM - VDC)**

CFM	AVAILABLE EXTERNAL STATIC PRESSURE (in. wg)									
	0.2		0.4		0.6		0.8		1.0	
	RPM	Vdc	RPM	Vdc	RPM	Vdc	RPM	Vdc	RPM	Vdc
1200	1217	4.9	1411	5.7	1576	6.4	1722	7.0	1855	7.5
1300	1283	5.2	1470	6.0	1631	6.6	1774	7.2	1904	7.7
1400	1351	5.5	1531	6.2	1688	6.9	1827	7.4	1955	7.9
1500	1420	5.8	1593	6.5	1746	7.1	1883	7.7	2008	8.2
1600	1491	6.1	1657	6.7	1805	7.3	1939	7.9	2062	8.4
1700	1563	6.4	1722	7.0	1866	7.6	1997	8.1	2118	8.6
1800	1635	6.6	1789	7.3	1928	7.8	2056	8.4	2174	8.8
1900	1709	6.9	1856	7.5	1991	8.1	2116	8.6	2232	9.1
2000	1784	7.3	1925	7.8	2056	8.4	2178	8.9	2291	9.3

CFM	AVAILABLE EXTERNAL STATIC PRESSURE (in. wg)									
	1.2		1.4		1.6		1.8		2.0	
	RPM	Vdc	RPM	Vdc	RPM	Vdc	RPM	Vdc	RPM	Vdc
1200	1979	8.0	2094	8.5	2204	9.0	2308	9.4	2409	9.8
1300	2025	8.2	2138	8.7	2246	9.1	2349	9.5	2447	9.9
1400	2074	8.4	2185	8.9	2291	9.3	2391	9.7	—	—
1500	2124	8.6	2234	9.1	2338	9.5	2436	9.9	—	—
1600	2176	8.8	2284	9.3	2386	9.7	—	—	—	—
1700	2230	9.1	2336	9.5	2436	9.9	—	—	—	—
1800	2285	9.3	2389	9.7	—	—	—	—	—	—
1900	2341	9.5	2444	9.9	—	—	—	—	—	—
2000	2398	9.7	—	—	—	—	—	—	—	—

High Static 1217-2460 RPM

NOTE: Fan tables include highest gas heat. Utilize static pressure deduction tables for lower gas heat capacities.

# Fan data (cont)

## RGV048 THREE PHASE — 4 TON HORIZONTAL SUPPLY (RPM - BHP)

CFM	AVAILABLE EXTERNAL STATIC PRESSURE (in. wg)									
	0.2		0.4		0.6		0.8		1.0	
	RPM	BHP	RPM	BHP	RPM	BHP	RPM	BHP	RPM	BHP
1200	1216	0.19	1411	0.30	1576	0.42	1722	0.55	1855	0.68
1300	1282	0.23	1470	0.34	1631	0.46	1773	0.60	1904	0.74
1400	1351	0.26	1531	0.38	1688	0.51	1827	0.65	1955	0.80
1500	1420	0.31	1593	0.43	1746	0.57	1882	0.71	2008	0.86
1600	1491	0.35	1657	0.48	1806	0.63	1940	0.78	2062	0.93
1700	1563	0.41	1722	0.54	1866	0.69	1997	0.85	2118	1.01
1800	1636	0.47	1788	0.61	1928	0.76	2056	0.92	2175	1.09
1900	1710	0.53	1856	0.68	1991	0.84	2116	1.01	2233	1.18
2000	1784	0.60	1924	0.76	2055	0.92	2178	1.10	2292	1.28

CFM	AVAILABLE EXTERNAL STATIC PRESSURE (in. wg)									
	1.2		1.4		1.6		1.8		2.0	
	RPM	BHP	RPM	BHP	RPM	BHP	RPM	BHP	RPM	BHP
1200	1978	0.83	2094	0.98	2204	1.15	2308	1.32	2409	1.50
1300	2025	0.89	2138	1.05	2246	1.21	2349	1.39	2447	1.57
1400	2073	0.95	2185	1.11	2291	1.28	2392	1.46	2488	1.64
1500	2124	1.02	2233	1.19	2337	1.36	2437	1.54	2532	1.73
1600	2176	1.10	2284	1.27	2386	1.45	2483	1.63	2577	1.82
1700	2230	1.18	2336	1.36	2436	1.54	2532	1.73	2624	1.92
1800	2285	1.27	2389	1.45	2488	1.64	2582	1.83	—	—
1900	2341	1.36	2443	1.55	2541	1.74	2634	1.94	—	—
2000	2399	1.46	2499	1.66	2595	1.85	—	—	—	—

NOTE: Fan tables include highest gas heat. Utilize static pressure deduction tables for lower gas heat capacities.

Standard Static 1216-1900 RPM, 0.72 Max BHP

Medium Static 1216-2170 RPM, 1.06 Max BHP

High Static 1216-2660 RPM, 1.96 Max BHP

## RGV048 THREE PHASE – STANDARD STATIC — 4 TON HORIZONTAL SUPPLY (RPM - VDC)

CFM	AVAILABLE EXTERNAL STATIC PRESSURE (in. wg)									
	0.2		0.4		0.6		0.8		1.0	
	RPM	Vdc	RPM	Vdc	RPM	Vdc	RPM	Vdc	RPM	Vdc
1200	1216	6.4	1411	7.4	1576	8.3	1722	9.1	1855	9.8
1300	1282	6.7	1470	7.7	1631	8.6	1773	9.3	—	—
1400	1351	7.1	1531	8.1	1688	8.9	1827	9.6	—	—
1500	1420	7.5	1593	8.4	1746	9.2	1882	9.9	—	—
1600	1491	7.8	1657	8.7	1806	9.5	—	—	—	—
1700	1563	8.2	1722	9.1	1866	9.8	—	—	—	—
1800	1636	8.6	1788	9.4	—	—	—	—	—	—
1900	1710	9.0	1856	9.8	—	—	—	—	—	—
2000	1784	9.4	—	—	—	—	—	—	—	—

CFM	AVAILABLE EXTERNAL STATIC PRESSURE (in. wg)									
	1.2		1.4		1.6		1.8		2.0	
	RPM	Vdc	RPM	Vdc	RPM	Vdc	RPM	Vdc	RPM	Vdc
1200	—	—	—	—	—	—	—	—	—	—
1300	—	—	—	—	—	—	—	—	—	—
1400	—	—	—	—	—	—	—	—	—	—
1500	—	—	—	—	—	—	—	—	—	—
1600	—	—	—	—	—	—	—	—	—	—
1700	—	—	—	—	—	—	—	—	—	—
1800	—	—	—	—	—	—	—	—	—	—
1900	—	—	—	—	—	—	—	—	—	—
2000	—	—	—	—	—	—	—	—	—	—

NOTE: Fan tables include highest gas heat. Utilize static pressure deduction tables for lower gas heat capacities.

Standard Static 1216-1900 RPM

**RGV048 THREE PHASE – MEDIUM STATIC — 4 TON HORIZONTAL SUPPLY (RPM - VDC)**

CFM	AVAILABLE EXTERNAL STATIC PRESSURE (in. wg)									
	0.2		0.4		0.6		0.8		1.0	
	RPM	Vdc	RPM	Vdc	RPM	Vdc	RPM	Vdc	RPM	Vdc
1200	1216	5.6	1411	6.5	1576	7.3	1722	7.9	1855	8.5
1300	1282	5.9	1470	6.8	1631	7.5	1773	8.2	1904	8.8
1400	1351	6.2	1531	7.1	1688	7.8	1827	8.4	1955	9.0
1500	1420	6.5	1593	7.3	1746	8.0	1882	8.7	2008	9.3
1600	1491	6.9	1657	7.6	1806	8.3	1940	8.9	2062	9.5
1700	1563	7.2	1722	7.9	1866	8.6	1997	9.2	2118	9.8
1800	1636	7.5	1788	8.2	1928	8.9	2056	9.5	—	—
1900	1710	7.9	1856	8.6	1991	9.2	2116	9.8	—	—
2000	1784	8.2	1924	8.9	2055	9.5	—	—	—	—

CFM	AVAILABLE EXTERNAL STATIC PRESSURE (in. wg)									
	1.2		1.4		1.6		1.8		2.0	
	RPM	Vdc	RPM	Vdc	RPM	Vdc	RPM	Vdc	RPM	Vdc
1200	1978	9.1	2094	9.6	—	—	—	—	—	—
1300	2025	9.3	2139	9.9	—	—	—	—	—	—
1400	2073	9.6	—	—	—	—	—	—	—	—
1500	2124	9.8	—	—	—	—	—	—	—	—
1600	—	—	—	—	—	—	—	—	—	—
1700	—	—	—	—	—	—	—	—	—	—
1800	—	—	—	—	—	—	—	—	—	—
1900	—	—	—	—	—	—	—	—	—	—
2000	—	—	—	—	—	—	—	—	—	—

NOTE: Fan tables include highest gas heat. Utilize static pressure deduction tables for lower gas heat capacities.

Medium Static 1216-2170 RPM

**RGV048 THREE PHASE – HIGH STATIC — 4 TON HORIZONTAL SUPPLY (RPM - VDC)**

CFM	AVAILABLE EXTERNAL STATIC PRESSURE (in. wg)									
	0.2		0.4		0.6		0.8		1.0	
	RPM	Vdc	RPM	Vdc	RPM	Vdc	RPM	Vdc	RPM	Vdc
1200	1216	4.6	1411	5.3	1576	5.9	1722	6.5	1855	7.0
1300	1282	4.8	1470	5.5	1631	6.1	1773	6.7	1904	7.2
1400	1351	5.1	1531	5.8	1688	6.3	1827	6.9	1955	7.3
1500	1420	5.3	1593	6.0	1746	6.6	1882	7.1	2008	7.5
1600	1491	5.6	1657	6.2	1806	6.8	1940	7.3	2062	7.8
1700	1563	5.9	1722	6.5	1866	7.0	1997	7.5	2118	8.0
1800	1636	6.2	1788	6.7	1928	7.2	2056	7.7	2175	8.2
1900	1710	6.4	1856	7.0	1991	7.5	2116	8.0	2233	8.4
2000	1784	6.7	1924	7.2	2055	7.7	2178	8.2	2292	8.6

CFM	AVAILABLE EXTERNAL STATIC PRESSURE (in. wg)									
	1.2		1.4		1.6		1.8		2.0	
	RPM	Vdc	RPM	Vdc	RPM	Vdc	RPM	Vdc	RPM	Vdc
1200	1978	7.4	2094	7.9	2204	8.3	2308	8.7	2409	9.1
1300	2025	7.6	2139	8.0	2246	8.4	2349	8.8	2447	9.2
1400	2073	7.8	2185	8.2	2291	8.6	2392	9.0	2488	9.4
1500	2124	8.0	2233	8.4	2337	8.8	2437	9.2	2532	9.5
1600	2176	8.2	2284	8.6	2386	9.0	2483	9.3	2577	9.7
1700	2230	8.4	2336	8.8	2436	9.2	2532	9.5	2624	9.9
1800	2285	8.6	2389	9.0	2488	9.4	2582	9.7	—	—
1900	2341	8.8	2443	9.2	2541	9.6	2634	9.9	—	—
2000	2399	9.0	2499	9.4	2595	9.8	—	—	—	—

High Static 1216-2660 RPM

NOTE: Fan tables include highest gas heat. Utilize static pressure deduction tables for lower gas heat capacities.

# Fan data (cont)

## RGV060 SINGLE PHASE — 5 TON HORIZONTAL SUPPLY (RPM - BHP)

CFM	AVAILABLE EXTERNAL STATIC PRESSURE (in. wg)									
	0.2		0.4		0.6		0.8		1.0	
	RPM	BHP	RPM	BHP	RPM	BHP	RPM	BHP	RPM	BHP
1500	1420	0.31	1593	0.43	1746	0.57	1883	0.71	2008	0.86
1625	1509	0.37	1673	0.50	1820	0.64	1954	0.79	2076	0.95
1750	1599	0.43	1755	0.57	1897	0.73	2026	0.88	2146	1.05
1875	1691	0.51	1839	0.66	1975	0.82	2101	0.98	2218	1.16
2000	1784	0.60	1925	0.76	2056	0.92	2178	1.10	2291	1.28
2125	1878	0.70	2011	0.86	2138	1.04	2255	1.22	2367	1.41
2250	1974	0.81	2100	0.98	2221	1.16	2335	1.35	—	—
2375	2070	0.94	2189	1.11	2305	1.30	—	—	—	—
2500	2166	1.08	2280	1.25	—	—	—	—	—	—

CFM	AVAILABLE EXTERNAL STATIC PRESSURE (in. wg)									
	1.2		1.4		1.6		1.8		2.0	
	RPM	BHP	RPM	BHP	RPM	BHP	RPM	BHP	RPM	BHP
1500	2124	1.02	2234	1.19	2338	1.36	—	—	—	—
1625	2190	1.12	2297	1.29	—	—	—	—	—	—
1750	2257	1.22	2362	1.40	—	—	—	—	—	—
1875	2327	1.34	—	—	—	—	—	—	—	—
2000	—	—	—	—	—	—	—	—	—	—
2125	—	—	—	—	—	—	—	—	—	—
2250	—	—	—	—	—	—	—	—	—	—
2375	—	—	—	—	—	—	—	—	—	—
2500	—	—	—	—	—	—	—	—	—	—

NOTE: Fan tables include highest gas heat. Utilize static pressure deduction tables for lower gas heat capacities.

Standard Static 1420-2150 RPM, 1.06 Max BHP

Medium Static 1420-2390 RPM, 1.44 Max BHP

## RGV 06 SINGLE PHASE – STANDARD STATIC — 5 TON HORIZONTAL SUPPLY (RPM - VDC)

CFM	AVAILABLE EXTERNAL STATIC PRESSURE (in. wg)									
	0.2		0.4		0.6		0.8		1.0	
	RPM	Vdc	RPM	Vdc	RPM	Vdc	RPM	Vdc	RPM	Vdc
1500	1420	6.6	1593	7.4	1746	8.1	1883	8.8	2008	9.3
1625	1509	7.0	1673	7.8	1820	8.5	1954	9.1	2076	9.7
1750	1599	7.4	1755	8.2	1897	8.8	2026	9.4	2146	10.0
1875	1691	7.9	1839	8.6	1975	9.2	2101	9.8	—	—
2000	1784	8.3	1925	9.0	2056	9.6	—	—	—	—
2125	1878	8.7	2011	9.4	2138	9.9	—	—	—	—
2250	1974	9.2	2100	9.8	—	—	—	—	—	—
2375	2070	9.6	—	—	—	—	—	—	—	—
2500	—	—	—	—	—	—	—	—	—	—

CFM	AVAILABLE EXTERNAL STATIC PRESSURE (in. wg)									
	1.2		1.4		1.6		1.8		2.0	
	RPM	Vdc	RPM	Vdc	RPM	Vdc	RPM	Vdc	RPM	Vdc
1500	2124	9.9	—	—	—	—	—	—	—	—
1625	—	—	—	—	—	—	—	—	—	—
1750	—	—	—	—	—	—	—	—	—	—
1875	—	—	—	—	—	—	—	—	—	—
2000	—	—	—	—	—	—	—	—	—	—
2125	—	—	—	—	—	—	—	—	—	—
2250	—	—	—	—	—	—	—	—	—	—
2375	—	—	—	—	—	—	—	—	—	—
2500	—	—	—	—	—	—	—	—	—	—

Standard Static 1420-2150 RPM

NOTE: Fan tables include highest gas heat. Utilize static pressure deduction tables for lower gas heat capacities.

**RGV060 SINGLE PHASE – MEDIUM STATIC — 5 TON HORIZONTAL SUPPLY (RPM - VDC)**

CFM	AVAILABLE EXTERNAL STATIC PRESSURE (in. wg)									
	0.2		0.4		0.6		0.8		1.0	
	RPM	Vdc	RPM	Vdc	RPM	Vdc	RPM	Vdc	RPM	Vdc
1500	1420	5.9	1593	6.7	1746	7.3	1883	7.9	2008	8.4
1625	1509	6.3	1673	7.0	1820	7.6	1954	8.2	2076	8.7
1750	1599	6.7	1755	7.3	1897	7.9	2026	8.5	2146	9.0
1875	1691	7.1	1839	7.7	1975	8.3	2101	8.8	2218	9.3
2000	1784	7.5	1925	8.1	2056	8.6	2178	9.1	2291	9.6
2125	1878	7.9	2011	8.4	2138	8.9	2255	9.4	2367	9.9
2250	1974	8.3	2100	8.8	2221	9.3	2335	9.8	—	—
2375	2070	8.7	2189	9.2	2305	9.6	—	—	—	—
2500	2166	9.1	2280	9.5	—	—	—	—	—	—

CFM	AVAILABLE EXTERNAL STATIC PRESSURE (in. wg)									
	1.2		1.4		1.6		1.8		2.0	
	RPM	Vdc	RPM	Vdc	RPM	Vdc	RPM	Vdc	RPM	Vdc
1500	2124	8.9	2234	9.3	2338	9.8	—	—	—	—
1625	2190	9.2	2297	9.6	—	—	—	—	—	—
1750	2257	9.4	2362	9.9	—	—	—	—	—	—
1875	2327	9.7	—	—	—	—	—	—	—	—
2000	—	—	—	—	—	—	—	—	—	—
2125	—	—	—	—	—	—	—	—	—	—
2250	—	—	—	—	—	—	—	—	—	—
2375	—	—	—	—	—	—	—	—	—	—
2500	—	—	—	—	—	—	—	—	—	—

Medium Static 1420-2390 RPM

NOTE: Fan tables include highest gas heat. Utilize static pressure deduction tables for lower gas heat capacities.

# Fan data (cont)

## RGV060 THREE PHASE — 5 TON HORIZONTAL SUPPLY (RPM - BHP)

CFM	AVAILABLE EXTERNAL STATIC PRESSURE (in. wg)									
	0.2		0.4		0.6		0.8		1.0	
	RPM	BHP	RPM	BHP	RPM	BHP	RPM	BHP	RPM	BHP
1500	1420	0.31	1593	0.43	1746	0.57	1883	0.71	2008	0.86
1625	1509	0.37	1673	0.50	1820	0.64	1954	0.79	2076	0.95
1750	1599	0.43	1755	0.57	1897	0.73	2026	0.88	2146	1.05
1875	1691	0.51	1839	0.66	1976	0.82	2102	0.99	2218	1.16
2000	1784	0.60	1924	0.76	2056	0.92	2178	1.10	2291	1.28
2125	1879	0.70	2011	0.86	2137	1.03	2256	1.22	2367	1.41
2250	1974	0.81	2099	0.98	2221	1.16	2335	1.35	2444	1.55
2375	2070	0.94	2189	1.11	2305	1.30	2416	1.49	2522	1.70
2500	2166	1.08	2280	1.25	2391	1.45	2499	1.65	2601	1.86

CFM	AVAILABLE EXTERNAL STATIC PRESSURE (in. wg)									
	1.2		1.4		1.6		1.8		2.0	
	RPM	BHP	RPM	BHP	RPM	BHP	RPM	BHP	RPM	BHP
1500	2124	1.02	2233	1.19	2337	1.36	2436	1.54	2532	1.73
1625	2190	1.12	2296	1.29	2398	1.47	2495	1.65	2589	1.85
1750	2257	1.22	2362	1.40	2462	1.59	2557	1.78	2648	1.97
1875	2327	1.34	2430	1.52	2528	1.72	2621	1.91	2710	2.11
2000	2398	1.46	2499	1.66	2595	1.85	2687	2.06	2775	2.27
2125	2471	1.60	2570	1.80	2665	2.01	2755	2.22	—	—
2250	2546	1.75	2643	1.96	2735	2.17	2824	2.39	—	—
2375	2622	1.91	2717	2.12	2807	2.34	—	—	—	—
2500	2699	2.08	2792	2.30	—	—	—	—	—	—

NOTE: Fan tables include highest gas heat. Utilize static pressure deduction tables for lower gas heat capacities.

Standard Static 1420-2150 RPM, 1.06 Max BHP

Medium Static 1420-2390 RPM, 1.44 Max BHP

High Static 1420-2836 RPM, 2.43 Max BHP

## RGV060 THREE PHASE – STANDARD STATIC — 5 TON HORIZONTAL SUPPLY (RPM - VDC)

CFM	AVAILABLE EXTERNAL STATIC PRESSURE (in. wg)									
	0.2		0.4		0.6		0.8		1.0	
	RPM	Vdc	RPM	Vdc	RPM	Vdc	RPM	Vdc	RPM	Vdc
1500	1420	6.6	1593	7.4	1746	8.1	1883	8.8	2008	9.3
1625	1509	7.0	1673	7.8	1820	8.5	1954	9.1	2076	9.7
1750	1599	7.4	1755	8.2	1897	8.8	2026	9.4	2146	10.0
1875	1691	7.9	1839	8.6	1976	9.2	2102	9.8	—	—
2000	1784	8.3	1924	8.9	2056	9.6	—	—	—	—
2125	1878	8.7	2011	9.4	2137	9.9	—	—	—	—
2250	1974	9.2	2099	9.8	—	—	—	—	—	—
2375	2070	9.6	—	—	—	—	—	—	—	—
2500	—	—	—	—	—	—	—	—	—	—

CFM	AVAILABLE EXTERNAL STATIC PRESSURE (in. wg)									
	1.2		1.4		1.6		1.8		2.0	
	RPM	Vdc	RPM	Vdc	RPM	Vdc	RPM	Vdc	RPM	Vdc
1500	2124	9.9	—	—	—	—	—	—	—	—
1625	—	—	—	—	—	—	—	—	—	—
1750	—	—	—	—	—	—	—	—	—	—
1875	—	—	—	—	—	—	—	—	—	—
2000	—	—	—	—	—	—	—	—	—	—
2125	—	—	—	—	—	—	—	—	—	—
2250	—	—	—	—	—	—	—	—	—	—
2375	—	—	—	—	—	—	—	—	—	—
2500	—	—	—	—	—	—	—	—	—	—

NOTE: Fan tables include highest gas heat. Utilize static pressure deduction tables for lower gas heat capacities.

Standard Static 1420-2150 RPM

**RGV060 THREE PHASE – MEDIUM STATIC — 5 TON HORIZONTAL SUPPLY (RPM - VDC)**

CFM	AVAILABLE EXTERNAL STATIC PRESSURE (in. wg)									
	0.2		0.4		0.6		0.8		1.0	
	RPM	Vdc	RPM	Vdc	RPM	Vdc	RPM	Vdc	RPM	Vdc
1500	1420	5.9	1593	6.7	1746	7.3	1883	7.9	2008	8.4
1625	1509	6.3	1673	7.0	1820	7.6	1954	8.2	2076	8.7
1750	1599	6.7	1755	7.3	1897	7.9	2026	8.5	2146	9.0
1875	1691	7.1	1839	7.7	1976	8.3	2102	8.8	2218	9.3
2000	1784	7.5	1924	8.1	2056	8.6	2178	9.1	2291	9.6
2125	1878	7.9	2011	8.4	2137	8.9	2256	9.4	2367	9.9
2250	1974	8.3	2099	8.8	2221	9.3	2335	9.8	—	—
2375	2070	8.7	2189	9.2	2305	9.6	—	—	—	—
2500	2166	9.1	2280	9.5	—	—	—	—	—	—

CFM	AVAILABLE EXTERNAL STATIC PRESSURE (in. wg)									
	1.2		1.4		1.6		1.8		2.0	
	RPM	Vdc	RPM	Vdc	RPM	Vdc	RPM	Vdc	RPM	Vdc
1500	2124	8.9	2233	9.3	2337	9.8	—	—	—	—
1625	2190	9.2	2296	9.6	—	—	—	—	—	—
1750	2257	9.4	2362	9.9	—	—	—	—	—	—
1875	2327	9.7	—	—	—	—	—	—	—	—
2000	—	—	—	—	—	—	—	—	—	—
2125	—	—	—	—	—	—	—	—	—	—
2250	—	—	—	—	—	—	—	—	—	—
2375	—	—	—	—	—	—	—	—	—	—
2500	—	—	—	—	—	—	—	—	—	—

NOTE: Fan tables include highest gas heat. Utilize static pressure deduction tables for lower gas heat capacities.

Medium Static 1420-2390 RPM

**RGV060 THREE PHASE – HIGH STATIC — 5 TON HORIZONTAL SUPPLY (RPM - VDC)**

CFM	AVAILABLE EXTERNAL STATIC PRESSURE (in. wg)									
	0.2		0.4		0.6		0.8		1.0	
	RPM	Vdc	RPM	Vdc	RPM	Vdc	RPM	Vdc	RPM	Vdc
1500	1420	5.0	1593	5.6	1746	6.2	1883	6.6	2008	7.1
1625	1509	5.3	1673	5.9	1820	6.4	1954	6.9	2076	7.3
1750	1599	5.6	1755	6.2	1897	6.7	2026	7.1	2146	7.6
1875	1691	6.0	1839	6.5	1976	7.0	2102	7.4	2218	7.8
2000	1784	6.3	1924	6.8	2056	7.2	2178	7.7	2291	8.1
2125	1878	6.6	2011	7.1	2137	7.5	2256	8.0	2367	8.3
2250	1974	7.0	2099	7.4	2221	7.8	2335	8.2	2444	8.6
2375	2070	7.3	2189	7.7	2305	8.1	2416	8.5	2522	8.9
2500	2166	7.6	2280	8.0	2391	8.4	2499	8.8	2601	9.2

CFM	AVAILABLE EXTERNAL STATIC PRESSURE (in. wg)									
	1.2		1.4		1.6		1.8		2.0	
	RPM	Vdc	RPM	Vdc	RPM	Vdc	RPM	Vdc	RPM	Vdc
1500	2124	7.5	2233	7.9	2337	8.2	2436	8.6	2532	8.9
1625	2190	7.7	2296	8.1	2398	8.5	2495	8.8	2589	9.1
1750	2257	8.0	2362	8.3	2462	8.7	2557	9.0	2648	9.3
1875	2327	8.2	2430	8.6	2528	8.9	2621	9.2	2710	9.6
2000	2398	8.5	2499	8.8	2595	9.2	2687	9.5	2775	9.8
2125	2471	8.7	2570	9.1	2665	9.4	2755	9.7	—	—
2250	2546	9.0	2643	9.3	2735	9.6	2824	10.0	—	—
2375	2622	9.2	2717	9.6	2807	9.9	—	—	—	—
2500	2699	9.5	2792	9.8	—	—	—	—	—	—

High Static 1420-2836 RPM

NOTE: Fan tables include highest gas heat. Utilize static pressure deduction tables for lower gas heat capacities.

# Fan data (cont)

## RGV072 THREE PHASE — 6 TON HORIZONTAL SUPPLY (RPM - BHP)

CFM	AVAILABLE EXTERNAL STATIC PRESSURE (in. wg)									
	0.2		0.4		0.6		0.8		1.0	
	RPM	BHP	RPM	BHP	RPM	BHP	RPM	BHP	RPM	BHP
1800	1537	0.38	1685	0.51	1824	0.64	1953	0.79	2071	0.94
1950	1641	0.47	1778	0.59	1911	0.74	2035	0.89	2150	1.05
2100	1748	0.56	1874	0.69	2000	0.84	2119	1.00	2231	1.17
2250	1855	0.67	1973	0.81	2091	0.96	2206	1.13	2314	1.31
2400	1964	0.80	2074	0.94	2185	1.10	2294	1.27	2399	1.45
2550	2074	0.94	2176	1.08	2281	1.25	2385	1.43	2486	1.62
2700	2185	1.10	2281	1.25	2379	1.42	2478	1.60	2575	1.80
2850	2296	1.27	2386	1.43	2479	1.60	2573	1.79	2666	1.99
3000	2408	1.47	2493	1.63	2581	1.81	2670	2.00	2759	2.21

CFM	AVAILABLE EXTERNAL STATIC PRESSURE (in. wg)									
	1.2		1.4		1.6		1.8		2.0	
	RPM	BHP	RPM	BHP	RPM	BHP	RPM	BHP	RPM	BHP
1800	2182	1.10	2285	1.26	2382	1.43	2476	1.60	2564	1.78
1950	2258	1.21	2359	1.39	2455	1.56	2547	1.74	2634	1.93
2100	2337	1.34	2436	1.52	2530	1.71	2620	1.90	2706	2.09
2250	2417	1.49	2514	1.67	2606	1.86	2695	2.06	2780	2.26
2400	2499	1.64	2594	1.84	2685	2.04	2771	2.24	—	—
2550	2583	1.81	2676	2.02	2765	2.22	—	—	—	—
2700	2669	2.00	2759	2.21	—	—	—	—	—	—
2850	2757	2.20	—	—	—	—	—	—	—	—
3000	—	—	—	—	—	—	—	—	—	—

NOTE: Fan tables include highest gas heat. Utilize static pressure deduction tables for lower gas heat capacities.

- Standard Static 1537-2300 RPM, 1.31 Max BHP
- Medium Static 1537-2530 RPM, 1.76 Max BHP
- High Static 1537-2836 RPM, 2.43 Max BHP

## RGV072 THREE PHASE – STANDARD STATIC — 6 TON HORIZONTAL SUPPLY (RPM - VDC)

CFM	AVAILABLE EXTERNAL STATIC PRESSURE (in. wg)									
	0.2		0.4		0.6		0.8		1.0	
	RPM	Vdc	RPM	Vdc	RPM	Vdc	RPM	Vdc	RPM	Vdc
1800	1537	6.7	1685	7.3	1824	7.9	1953	8.5	2071	9.0
1950	1641	7.1	1778	7.7	1911	8.3	2035	8.8	2150	9.3
2100	1748	7.6	1874	8.1	2000	8.7	2119	9.2	2231	9.7
2250	1855	8.1	1973	8.6	2091	9.1	2206	9.6	—	—
2400	1964	8.5	2074	9.0	2185	9.5	2294	10.0	—	—
2550	2074	9.0	2176	9.5	2281	9.9	—	—	—	—
2700	2185	9.5	2281	9.9	—	—	—	—	—	—
2850	2296	10.0	—	—	—	—	—	—	—	—
3000	—	—	—	—	—	—	—	—	—	—

CFM	AVAILABLE EXTERNAL STATIC PRESSURE (in. wg)									
	1.2		1.4		1.6		1.8		2.0	
	RPM	Vdc	RPM	Vdc	RPM	Vdc	RPM	Vdc	RPM	Vdc
1800	2182	9.5	2285	9.9	—	—	—	—	—	—
1950	2258	9.8	—	—	—	—	—	—	—	—
2100	—	—	—	—	—	—	—	—	—	—
2250	—	—	—	—	—	—	—	—	—	—
2400	—	—	—	—	—	—	—	—	—	—
2550	—	—	—	—	—	—	—	—	—	—
2700	—	—	—	—	—	—	—	—	—	—
2850	—	—	—	—	—	—	—	—	—	—
3000	—	—	—	—	—	—	—	—	—	—

NOTE: Fan tables include highest gas heat. Utilize static pressure deduction tables for lower gas heat capacities.

- Standard Static 1537-2300 RPM

**RGV072 THREE PHASE – MEDIUM STATIC — 6 TON HORIZONTAL SUPPLY (RPM - VDC)**

CFM	AVAILABLE EXTERNAL STATIC PRESSURE (in. wg)									
	0.2		0.4		0.6		0.8		1.0	
	RPM	Vdc	RPM	Vdc	RPM	Vdc	RPM	Vdc	RPM	Vdc
1800	1537	6.1	1685	6.7	1824	7.2	1953	7.7	2071	8.2
1950	1641	6.5	1778	7.0	1911	7.6	2035	8.0	2150	8.5
2100	1748	6.9	1874	7.4	2000	7.9	2119	8.4	2231	8.8
2250	1855	7.3	1973	7.8	2091	8.3	2206	8.7	2314	9.1
2400	1964	7.8	2074	8.2	2185	8.6	2294	9.1	2399	9.5
2550	2074	8.2	2176	8.6	2281	9.0	2385	9.4	2486	9.8
2700	2185	8.6	2281	9.0	2379	9.4	2478	9.8	—	—
2850	2296	9.1	2386	9.4	2479	9.8	—	—	—	—
3000	2408	9.5	2493	9.9	—	—	—	—	—	—

CFM	AVAILABLE EXTERNAL STATIC PRESSURE (in. wg)									
	1.2		1.4		1.6		1.8		2.0	
	RPM	Vdc	RPM	Vdc	RPM	Vdc	RPM	Vdc	RPM	Vdc
1800	2182	8.6	2285	9.0	2382	9.4	2476	9.8	—	—
1950	2258	8.9	2359	9.3	2455	9.7	—	—	—	—
2100	2337	9.2	2436	9.6	2530	10.0	—	—	—	—
2250	2417	9.6	2514	9.9	—	—	—	—	—	—
2400	2499	9.9	—	—	—	—	—	—	—	—
2550	—	—	—	—	—	—	—	—	—	—
2700	—	—	—	—	—	—	—	—	—	—
2850	—	—	—	—	—	—	—	—	—	—
3000	—	—	—	—	—	—	—	—	—	—

NOTE: Fan tables include highest gas heat. Utilize static pressure deduction tables for lower gas heat capacities.

Medium Static 1537-2530 RPM

**RGV072 THREE PHASE – HIGH STATIC — 6 TON HORIZONTAL SUPPLY (RPM - VDC)**

CFM	AVAILABLE EXTERNAL STATIC PRESSURE (in. wg)									
	0.2		0.4		0.6		0.8		1.0	
	RPM	Vdc	RPM	Vdc	RPM	Vdc	RPM	Vdc	RPM	Vdc
1800	1537	5.4	1685	5.9	1824	6.4	1953	6.9	2071	7.3
1950	1641	5.8	1778	6.3	1911	6.7	2035	7.2	2150	7.6
2100	1748	6.2	1874	6.6	2000	7.1	2119	7.5	2231	7.9
2250	1855	6.5	1973	7.0	2091	7.4	2206	7.8	2314	8.2
2400	1964	6.9	2074	7.3	2185	7.7	2294	8.1	2399	8.5
2550	2074	7.3	2176	7.7	2281	8.0	2385	8.4	2486	8.8
2700	2185	7.7	2281	8.0	2379	8.4	2478	8.7	2575	9.1
2850	2296	8.1	2386	8.4	2479	8.7	2573	9.1	2666	9.4
3000	2408	8.5	2493	8.8	2581	9.1	2670	9.4	2759	9.7

CFM	AVAILABLE EXTERNAL STATIC PRESSURE (in. wg)									
	1.2		1.4		1.6		1.8		2.0	
	RPM	Vdc	RPM	Vdc	RPM	Vdc	RPM	Vdc	RPM	Vdc
1800	2182	7.7	2285	8.1	2382	8.4	2476	8.7	2564	9.0
1950	2258	8.0	2359	8.3	2455	8.7	2547	9.0	2634	9.3
2100	2337	8.2	2436	8.6	2530	8.9	2620	9.2	2706	9.5
2250	2417	8.5	2514	8.9	2606	9.2	2695	9.5	2780	9.8
2400	2499	8.8	2594	9.1	2685	9.5	2771	9.8	—	—
2550	2583	9.1	2676	9.4	2765	9.7	—	—	—	—
2700	2669	9.4	2759	9.7	—	—	—	—	—	—
2850	2757	9.7	—	—	—	—	—	—	—	—
3000	—	—	—	—	—	—	—	—	—	—

High Static 1537-2836 RPM

NOTE: Fan tables include highest gas heat. Utilize static pressure deduction tables for lower gas heat capacities.

# Fan data (cont)

## RAV036 SINGLE PHASE — 3 TON VERTICAL SUPPLY (RPM - BHP)

CFM	AVAILABLE EXTERNAL STATIC PRESSURE (in. wg)									
	0.2		0.4		0.6		0.8		1.0	
	RPM	BHP	RPM	BHP	RPM	BHP	RPM	BHP	RPM	BHP
900	1040	0.08	1307	0.16	1526	0.25	1705	0.35	1859	0.45
975	1082	0.09	1336	0.17	1554	0.26	1736	0.36	1892	0.47
1050	1127	0.10	1366	0.18	1582	0.28	1766	0.38	1925	0.50
1125	1175	0.11	1398	0.19	1609	0.29	1795	0.40	1956	0.52
1200	1225	0.13	1434	0.21	1638	0.31	1822	0.42	1984	0.54
1275	1277	0.15	1472	0.22	1667	0.32	1849	0.44	2012	0.57
1350	1330	0.16	1514	0.24	1699	0.34	1878	0.46	2040	0.59
1425	1385	0.19	1557	0.26	1734	0.36	1906	0.48	2068	0.62
1500	1440	0.21	1603	0.29	1771	0.39	1937	0.51	2095	0.64

CFM	AVAILABLE EXTERNAL STATIC PRESSURE (in. wg)									
	1.2		1.4		1.6		1.8		2.0	
	RPM	BHP	RPM	BHP	RPM	BHP	RPM	BHP	RPM	BHP
900	1995	0.55	2119	0.66	2234	0.78	2342	0.89	2444	1.02
975	2031	0.58	2156	0.70	2272	0.82	2380	0.94	2482	1.06
1050	2065	0.61	2192	0.73	2309	0.86	2418	0.98	—	—
1125	2098	0.64	2226	0.77	2345	0.90	2454	1.03	—	—
1200	2129	0.67	2259	0.80	2379	0.94	2490	1.07	—	—
1275	2159	0.70	2291	0.84	2412	0.98	—	—	—	—
1350	2187	0.73	2321	0.87	2444	1.02	—	—	—	—
1425	2215	0.76	2350	0.90	2474	1.05	—	—	—	—
1500	2242	0.78	2378	0.94	—	—	—	—	—	—

Standard Static 1040-1890 RPM, 0.44 Max BHP

Medium Static 1040-2190 RPM, 0.71 Max BHP

High Static 1040-2490 RPM, 1.07 Max BHP

## RAV036 SINGLE PHASE – STANDARD STATIC — 3 TON VERTICAL SUPPLY (RPM - VDC)

CFM	AVAILABLE EXTERNAL STATIC PRESSURE (in. wg)									
	0.2		0.4		0.6		0.8		1.0	
	RPM	Vdc	RPM	Vdc	RPM	Vdc	RPM	Vdc	RPM	Vdc
900	1040	5.5	1307	6.9	1526	8.1	1705	9.0	—	—
975	1082	5.7	1336	7.1	1554	8.2	1736	9.2	—	—
1050	1127	6.0	1366	7.2	1582	8.4	1766	9.3	—	—
1125	1175	6.2	1398	7.4	1609	8.5	1795	9.5	—	—
1200	1225	6.5	1434	7.6	1638	8.7	1822	9.6	—	—
1275	1277	6.8	1472	7.8	1667	8.8	1849	9.8	—	—
1350	1330	7.0	1514	8.0	1699	9.0	—	—	—	—
1425	1385	7.3	1557	8.2	1734	9.2	—	—	—	—
1500	1440	7.6	1603	8.5	1771	9.4	—	—	—	—

CFM	AVAILABLE EXTERNAL STATIC PRESSURE (in. wg)									
	1.2		1.4		1.6		1.8		2.0	
	RPM	Vdc	RPM	Vdc	RPM	Vdc	RPM	Vdc	RPM	Vdc
900	—	—	—	—	—	—	—	—	—	—
975	—	—	—	—	—	—	—	—	—	—
1050	—	—	—	—	—	—	—	—	—	—
1125	—	—	—	—	—	—	—	—	—	—
1200	—	—	—	—	—	—	—	—	—	—
1275	—	—	—	—	—	—	—	—	—	—
1350	—	—	—	—	—	—	—	—	—	—
1425	—	—	—	—	—	—	—	—	—	—
1500	—	—	—	—	—	—	—	—	—	—

Standard Static 1040-1890 RPM

**RAV036 SINGLE PHASE – MEDIUM STATIC — 3 TON VERTICAL SUPPLY (RPM - VDC)**

CFM	AVAILABLE EXTERNAL STATIC PRESSURE (in. wg)									
	0.2		0.4		0.6		0.8		1.0	
	RPM	Vdc	RPM	Vdc	RPM	Vdc	RPM	Vdc	RPM	Vdc
900	1040	4.7	1307	6.0	1526	7.0	1705	7.8	1859	8.5
975	1082	4.9	1336	6.1	1554	7.1	1736	7.9	1892	8.6
1050	1127	5.1	1366	6.2	1582	7.2	1766	8.1	1925	8.8
1125	1175	5.4	1398	6.4	1609	7.3	1795	8.2	1956	8.9
1200	1225	5.6	1434	6.5	1638	7.5	1822	8.3	1984	9.1
1275	1277	5.8	1472	6.7	1667	7.6	1849	8.4	2012	9.2
1350	1330	6.1	1514	6.9	1699	7.8	1878	8.6	2040	9.3
1425	1385	6.3	1557	7.1	1734	7.9	1906	8.7	2068	9.4
1500	1440	6.6	1603	7.3	1771	8.1	1937	8.8	2095	9.6

CFM	AVAILABLE EXTERNAL STATIC PRESSURE (in. wg)									
	1.2		1.4		1.6		1.8		2.0	
	RPM	Vdc	RPM	Vdc	RPM	Vdc	RPM	Vdc	RPM	Vdc
900	1995	9.1	2119	9.7	—	—	—	—	—	—
975	2031	9.3	2156	9.8	—	—	—	—	—	—
1050	2065	9.4	—	—	—	—	—	—	—	—
1125	2098	9.6	—	—	—	—	—	—	—	—
1200	2129	9.7	—	—	—	—	—	—	—	—
1275	2159	9.9	—	—	—	—	—	—	—	—
1350	2187	10.0	—	—	—	—	—	—	—	—
1425	—	—	—	—	—	—	—	—	—	—
1500	—	—	—	—	—	—	—	—	—	—

Medium Static 1040-2190 RPM

**RAV036 SINGLE PHASE – HIGH STATIC — 3 TON VERTICAL SUPPLY (RPM - VDC)**

CFM	AVAILABLE EXTERNAL STATIC PRESSURE (in. wg)									
	0.2		0.4		0.6		0.8		1.0	
	RPM	Vdc	RPM	Vdc	RPM	Vdc	RPM	Vdc	RPM	Vdc
900	1040	4.2	1307	5.2	1526	6.1	1705	6.8	1859	7.5
975	1082	4.3	1336	5.4	1554	6.2	1736	7.0	1892	7.6
1050	1127	4.5	1366	5.5	1582	6.4	1766	7.1	1925	7.7
1125	1175	4.7	1398	5.6	1609	6.5	1795	7.2	1956	7.9
1200	1225	4.9	1434	5.8	1638	6.6	1822	7.3	1984	8.0
1275	1277	5.1	1472	5.9	1667	6.7	1849	7.4	2012	8.1
1350	1330	5.3	1514	6.1	1699	6.8	1878	7.5	2040	8.2
1425	1385	5.6	1557	6.3	1734	7.0	1906	7.7	2068	8.3
1500	1440	5.8	1603	6.4	1771	7.1	1937	7.8	2095	8.4

CFM	AVAILABLE EXTERNAL STATIC PRESSURE (in. wg)									
	1.2		1.4		1.6		1.8		2.0	
	RPM	Vdc	RPM	Vdc	RPM	Vdc	RPM	Vdc	RPM	Vdc
900	1995	8.0	2119	8.5	2234	9.0	2342	9.4	2444	9.8
975	2031	8.2	2156	8.7	2272	9.1	2380	9.6	2482	10.0
1050	2065	8.3	2192	8.8	2309	9.3	2418	9.7	—	—
1125	2098	8.4	2226	8.9	2345	9.4	2454	9.9	—	—
1200	2129	8.6	2259	9.1	2379	9.6	2490	10.0	—	—
1275	2159	8.7	2291	9.2	2412	9.7	—	—	—	—
1350	2187	8.8	2321	9.3	2444	9.8	—	—	—	—
1425	2215	8.9	2350	9.4	2474	9.9	—	—	—	—
1500	2242	9.0	2378	9.6	—	—	—	—	—	—

High Static 1040-2490 RPM

# Fan data (cont)

## RAV036 THREE PHASE — 3 TON VERTICAL SUPPLY (RPM - VDC)

CFM	AVAILABLE EXTERNAL STATIC PRESSURE (in. wg)									
	0.2		0.4		0.6		0.8		1.0	
	RPM	BHP	RPM	BHP	RPM	BHP	RPM	BHP	RPM	BHP
900	1040	0.08	1307	0.16	1526	0.25	1705	0.35	1859	0.45
975	1082	0.09	1336	0.17	1554	0.26	1736	0.36	1892	0.47
1050	1127	0.10	1366	0.18	1582	0.28	1766	0.38	1925	0.50
1125	1175	0.11	1398	0.19	1609	0.29	1795	0.40	1956	0.52
1200	1225	0.13	1434	0.21	1638	0.31	1822	0.42	1984	0.54
1275	1277	0.15	1472	0.22	1667	0.32	1849	0.44	2012	0.57
1350	1330	0.16	1514	0.24	1699	0.34	1878	0.46	2040	0.59
1425	1385	0.19	1557	0.26	1734	0.36	1906	0.48	2068	0.62
1500	1440	0.21	1603	0.29	1771	0.39	1937	0.51	2095	0.64

CFM	AVAILABLE EXTERNAL STATIC PRESSURE (in. wg)									
	1.2		1.4		1.6		1.8		2.0	
	RPM	BHP	RPM	BHP	RPM	BHP	RPM	BHP	RPM	BHP
900	1995	0.55	2119	0.66	2234	0.78	2342	0.89	2444	1.02
975	2031	0.58	2156	0.70	2272	0.82	2380	0.94	2482	1.06
1050	2065	0.61	2192	0.73	2309	0.86	2418	0.98	—	—
1125	2098	0.64	2226	0.77	2345	0.90	2454	1.03	—	—
1200	2129	0.67	2259	0.80	2379	0.94	2490	1.07	—	—
1275	2159	0.70	2291	0.84	2412	0.98	—	—	—	—
1350	2187	0.73	2321	0.87	2444	1.02	—	—	—	—
1425	2215	0.76	2350	0.90	2474	1.05	—	—	—	—
1500	2242	0.78	2378	0.94	—	—	—	—	—	—

Standard Static 1040-1890 RPM, 0.44 Max BHP

Medium Static 1040-2190 RPM, 0.71 Max BHP

High Static 1040-2490 RPM, 1.07 Max BHP

## RAV036 THREE PHASE – STANDARD STATIC — 3 TON VERTICAL SUPPLY (RPM - VDC)

CFM	AVAILABLE EXTERNAL STATIC PRESSURE (in. wg)									
	0.2		0.4		0.6		0.8		1.0	
	RPM	Vdc	RPM	Vdc	RPM	Vdc	RPM	Vdc	RPM	Vdc
900	1040	5.5	1307	6.9	1526	8.1	1705	9.0	—	—
975	1082	5.7	1336	7.1	1554	8.2	1736	9.2	—	—
1050	1127	6.0	1366	7.2	1582	8.4	1766	9.3	—	—
1125	1175	6.2	1398	7.4	1609	8.5	1795	9.5	—	—
1200	1225	6.5	1434	7.6	1638	8.7	1822	9.6	—	—
1275	1277	6.8	1472	7.8	1667	8.8	1849	9.8	—	—
1350	1330	7.0	1514	8.0	1699	9.0	—	—	—	—
1425	1385	7.3	1557	8.2	1734	9.2	—	—	—	—
1500	1440	7.6	1603	8.5	1771	9.4	—	—	—	—

CFM	AVAILABLE EXTERNAL STATIC PRESSURE (in. wg)									
	1.2		1.4		1.6		1.8		2.0	
	RPM	Vdc	RPM	Vdc	RPM	Vdc	RPM	Vdc	RPM	Vdc
900	—	—	—	—	—	—	—	—	—	—
975	—	—	—	—	—	—	—	—	—	—
1050	—	—	—	—	—	—	—	—	—	—
1125	—	—	—	—	—	—	—	—	—	—
1200	—	—	—	—	—	—	—	—	—	—
1275	—	—	—	—	—	—	—	—	—	—
1350	—	—	—	—	—	—	—	—	—	—
1425	—	—	—	—	—	—	—	—	—	—
1500	—	—	—	—	—	—	—	—	—	—

Standard Static 1040-1890 RPM

**RAV036 THREE PHASE – MEDIUM STATIC — 3 TON VERTICAL SUPPLY (RPM - VDC)**

CFM	AVAILABLE EXTERNAL STATIC PRESSURE (in. wg)									
	0.2		0.4		0.6		0.8		1.0	
	RPM	Vdc	RPM	Vdc	RPM	Vdc	RPM	Vdc	RPM	Vdc
900	1040	4.7	1307	6.0	1526	7.0	1705	7.8	1859	8.5
975	1082	4.9	1336	6.1	1554	7.1	1736	7.9	1892	8.6
1050	1127	5.1	1366	6.2	1582	7.2	1766	8.1	1925	8.8
1125	1175	5.4	1398	6.4	1609	7.3	1795	8.2	1956	8.9
1200	1225	5.6	1434	6.5	1638	7.5	1822	8.3	1984	9.1
1275	1277	5.8	1472	6.7	1667	7.6	1849	8.4	2012	9.2
1350	1330	6.1	1514	6.9	1699	7.8	1878	8.6	2040	9.3
1425	1385	6.3	1557	7.1	1734	7.9	1906	8.7	2068	9.4
1500	1440	6.6	1603	7.3	1771	8.1	1937	8.8	2095	9.6

CFM	AVAILABLE EXTERNAL STATIC PRESSURE (in. wg)									
	1.2		1.4		1.6		1.8		2.0	
	RPM	Vdc	RPM	Vdc	RPM	Vdc	RPM	Vdc	RPM	Vdc
900	1995	9.1	2119	9.7	—	—	—	—	—	—
975	2031	9.3	2156	9.8	—	—	—	—	—	—
1050	2065	9.4	—	—	—	—	—	—	—	—
1125	2098	9.6	—	—	—	—	—	—	—	—
1200	2129	9.7	—	—	—	—	—	—	—	—
1275	2159	9.9	—	—	—	—	—	—	—	—
1350	2187	10.0	—	—	—	—	—	—	—	—
1425	—	—	—	—	—	—	—	—	—	—
1500	—	—	—	—	—	—	—	—	—	—

Medium Static 1040-2190 RPM

**RAV036 THREE PHASE – HIGH STATIC — 3 TON VERTICAL SUPPLY (RPM - VDC)**

CFM	AVAILABLE EXTERNAL STATIC PRESSURE (in. wg)									
	0.2		0.4		0.6		0.8		1.0	
	RPM	Vdc	RPM	Vdc	RPM	Vdc	RPM	Vdc	RPM	Vdc
900	1040	4.2	1307	5.2	1526	6.1	1705	6.8	1859	7.5
975	1082	4.3	1336	5.4	1554	6.2	1736	7.0	1892	7.6
1050	1127	4.5	1366	5.5	1582	6.4	1766	7.1	1925	7.7
1125	1175	4.7	1398	5.6	1609	6.5	1795	7.2	1956	7.9
1200	1225	4.9	1434	5.8	1638	6.6	1822	7.3	1984	8.0
1275	1277	5.1	1472	5.9	1667	6.7	1849	7.4	2012	8.1
1350	1330	5.3	1514	6.1	1699	6.8	1878	7.5	2040	8.2
1425	1385	5.6	1557	6.3	1734	7.0	1906	7.7	2068	8.3
1500	1440	5.8	1603	6.4	1771	7.1	1937	7.8	2095	8.4

CFM	AVAILABLE EXTERNAL STATIC PRESSURE (in. wg)									
	1.2		1.4		1.6		1.8		2.0	
	RPM	Vdc	RPM	Vdc	RPM	Vdc	RPM	Vdc	RPM	Vdc
900	1995	8.0	2119	8.5	2234	9.0	2342	9.4	2444	9.8
975	2031	8.2	2156	8.7	2272	9.1	2380	9.6	2482	10.0
1050	2065	8.3	2192	8.8	2309	9.3	2418	9.7	—	—
1125	2098	8.4	2226	8.9	2345	9.4	2454	9.9	—	—
1200	2129	8.6	2259	9.1	2379	9.6	2490	10.0	—	—
1275	2159	8.7	2291	9.2	2412	9.7	—	—	—	—
1350	2187	8.8	2321	9.3	2444	9.8	—	—	—	—
1425	2215	8.9	2350	9.4	2474	9.9	—	—	—	—
1500	2242	9.0	2378	9.6	—	—	—	—	—	—

High Static 1040-2490 RPM

# Fan data (cont)

## RAV048 SINGLE PHASE — 4 TON VERTICAL SUPPLY (RPM - BHP)

CFM	AVAILABLE EXTERNAL STATIC PRESSURE (in. wg)									
	0.2		0.4		0.6		0.8		1.0	
	RPM	BHP	RPM	BHP	RPM	BHP	RPM	BHP	RPM	BHP
1200	1120	0.15	1327	0.25	1506	0.37	1667	0.50	1814	0.65
1300	1178	0.18	1375	0.28	1549	0.40	1705	0.54	1849	0.69
1400	1238	0.21	1424	0.31	1593	0.44	1745	0.57	1886	0.73
1500	1300	0.24	1476	0.35	1639	0.47	1788	0.62	1925	0.77
1600	1365	0.27	1530	0.39	1688	0.52	1832	0.66	1966	0.82
1700	1430	0.31	1586	0.43	1737	0.56	1878	0.71	2009	0.87
1800	1497	0.36	1644	0.48	1789	0.61	1925	0.76	2053	0.93
1900	1565	0.41	1703	0.53	1842	0.67	1974	0.82	2099	0.99
2000	1633	0.46	1764	0.59	1897	0.73	2025	0.89	2146	1.05

CFM	AVAILABLE EXTERNAL STATIC PRESSURE (in. wg)									
	1.2		1.4		1.6		1.8		2.0	
	RPM	BHP	RPM	BHP	RPM	BHP	RPM	BHP	RPM	BHP
1200	1950	0.81	2077	0.97	2195	1.15	2307	1.33	2411	1.52
1300	1983	0.85	2108	1.02	2225	1.19	2336	1.38	2442	1.58
1400	2017	0.89	2140	1.06	2256	1.24	2367	1.43	—	—
1500	2053	0.93	2174	1.11	2289	1.29	2399	1.49	—	—
1600	2092	0.98	2210	1.16	2323	1.35	2431	1.55	—	—
1700	2132	1.04	2248	1.22	2359	1.41	—	—	—	—
1800	2173	1.10	2288	1.28	2397	1.47	—	—	—	—
1900	2217	1.16	2329	1.35	2436	1.54	—	—	—	—
2000	2262	1.23	2372	1.42	—	—	—	—	—	—

Standard Static 1120-1900 RPM, 0.72 Max BHP

Medium Static 1120-2170 RPM, 1.06 Max BHP

High Static 1120-2460 RPM, 1.53 Max BHP

## RAV048 SINGLE PHASE – STANDARD STATIC — 4 TON VERTICAL SUPPLY (RPM - VDC)

CFM	AVAILABLE EXTERNAL STATIC PRESSURE (in. wg)									
	0.2		0.4		0.6		0.8		1.0	
	RPM	Vdc	RPM	Vdc	RPM	Vdc	RPM	Vdc	RPM	Vdc
1200	1120	5.9	1327	7.0	1506	7.9	1667	8.8	1814	9.5
1300	1178	6.2	1375	7.2	1549	8.2	1705	9.0	1849	9.7
1400	1238	6.5	1424	7.5	1593	8.4	1745	9.2	1886	9.9
1500	1300	6.8	1476	7.8	1639	8.6	1788	9.4	—	—
1600	1365	7.2	1530	8.1	1688	8.9	1832	9.6	—	—
1700	1430	7.5	1586	8.3	1737	9.1	1878	9.9	—	—
1800	1497	7.9	1644	8.7	1789	9.4	—	—	—	—
1900	1565	8.2	1703	9.0	1842	9.7	—	—	—	—
2000	1633	8.6	1764	9.3	1897	10.0	—	—	—	—

CFM	AVAILABLE EXTERNAL STATIC PRESSURE (in. wg)									
	1.2		1.4		1.6		1.8		2.0	
	RPM	Vdc	RPM	Vdc	RPM	Vdc	RPM	Vdc	RPM	Vdc
1200	—	—	—	—	—	—	—	—	—	—
1300	—	—	—	—	—	—	—	—	—	—
1400	—	—	—	—	—	—	—	—	—	—
1500	—	—	—	—	—	—	—	—	—	—
1600	—	—	—	—	—	—	—	—	—	—
1700	—	—	—	—	—	—	—	—	—	—
1800	—	—	—	—	—	—	—	—	—	—
1900	—	—	—	—	—	—	—	—	—	—
2000	—	—	—	—	—	—	—	—	—	—

Standard Static 1120-1900 RPM

**RAV048 SINGLE PHASE – MEDIUM STATIC — 4 TON VERTICAL SUPPLY (RPM - VDC)**

CFM	AVAILABLE EXTERNAL STATIC PRESSURE (in. wg)									
	0.2		0.4		0.6		0.8		1.0	
	RPM	Vdc	RPM	Vdc	RPM	Vdc	RPM	Vdc	RPM	Vdc
1200	1120	5.2	1327	6.1	1506	6.9	1667	7.7	1814	8.4
1300	1178	5.4	1375	6.3	1549	7.1	1705	7.9	1849	8.5
1400	1238	5.7	1424	6.6	1593	7.3	1745	8.0	1886	8.7
1500	1300	6.0	1476	6.8	1639	7.6	1788	8.2	1925	8.9
1600	1365	6.3	1530	7.1	1688	7.8	1832	8.4	1966	9.1
1700	1430	6.6	1586	7.3	1737	8.0	1878	8.7	2009	9.3
1800	1497	6.9	1644	7.6	1789	8.2	1925	8.9	2053	9.5
1900	1565	7.2	1703	7.8	1842	8.5	1974	9.1	2099	9.7
2000	1633	7.5	1764	8.1	1897	8.7	2025	9.3	2146	9.9

CFM	AVAILABLE EXTERNAL STATIC PRESSURE (in. wg)									
	1.2		1.4		1.6		1.8		2.0	
	RPM	Vdc	RPM	Vdc	RPM	Vdc	RPM	Vdc	RPM	Vdc
1200	1950	9.0	2077	9.6	—	—	—	—	—	—
1300	1983	9.1	2108	9.7	—	—	—	—	—	—
1400	2017	9.3	2140	9.9	—	—	—	—	—	—
1500	2053	9.5	—	—	—	—	—	—	—	—
1600	2092	9.6	—	—	—	—	—	—	—	—
1700	2132	9.8	—	—	—	—	—	—	—	—
1800	—	—	—	—	—	—	—	—	—	—
1900	—	—	—	—	—	—	—	—	—	—
2000	—	—	—	—	—	—	—	—	—	—

Medium Static 1120-2170 RPM

**RAV048 SINGLE PHASE – HIGH STATIC — 4 TON VERTICAL SUPPLY (RPM - VDC)**

CFM	AVAILABLE EXTERNAL STATIC PRESSURE (in. wg)									
	0.2		0.4		0.6		0.8		1.0	
	RPM	Vdc	RPM	Vdc	RPM	Vdc	RPM	Vdc	RPM	Vdc
1200	1120	4.6	1327	5.4	1506	6.1	1667	6.8	1814	7.4
1300	1178	4.8	1375	5.6	1549	6.3	1705	6.9	1849	7.5
1400	1238	5.0	1424	5.8	1593	6.5	1745	7.1	1886	7.7
1500	1300	5.3	1476	6.0	1639	6.7	1788	7.3	1925	7.8
1600	1365	5.5	1530	6.2	1688	6.9	1832	7.4	1966	8.0
1700	1430	5.8	1586	6.4	1737	7.1	1878	7.6	2009	8.2
1800	1497	6.1	1644	6.7	1789	7.3	1925	7.8	2053	8.3
1900	1565	6.4	1703	6.9	1842	7.5	1974	8.0	2099	8.5
2000	1633	6.6	1764	7.2	1897	7.7	2025	8.2	2146	8.7

CFM	AVAILABLE EXTERNAL STATIC PRESSURE (in. wg)									
	1.2		1.4		1.6		1.8		2.0	
	RPM	Vdc	RPM	Vdc	RPM	Vdc	RPM	Vdc	RPM	Vdc
1200	1950	7.9	2077	8.4	2195	8.9	2307	9.4	2411	9.8
1300	1983	8.1	2108	8.6	2225	9.0	2336	9.5	2442	9.9
1400	2017	8.2	2140	8.7	2256	9.2	2367	9.6	—	—
1500	2053	8.3	2174	8.8	2289	9.3	2399	9.8	—	—
1600	2092	8.5	2210	9.0	2323	9.4	2431	9.9	—	—
1700	2132	8.7	2248	9.1	2359	9.6	—	—	—	—
1800	2173	8.8	2288	9.3	2397	9.7	—	—	—	—
1900	2217	9.0	2329	9.5	2436	9.9	—	—	—	—
2000	2262	9.2	2372	9.6	—	—	—	—	—	—

High Static 1120-2460 RPM

# Fan data (cont)

## RAV048 THREE PHASE — 4 TON VERTICAL SUPPLY (RPM - BHP)

CFM	AVAILABLE EXTERNAL STATIC PRESSURE (in. wg)									
	0.2		0.4		0.6		0.8		1.0	
	RPM	BHP	RPM	BHP	RPM	BHP	RPM	BHP	RPM	BHP
1200	1115	0.15	1332	0.26	1513	0.37	1665	0.50	1801	0.63
1300	1174	0.17	1376	0.28	1557	0.41	1709	0.54	1843	0.67
1400	1236	0.20	1422	0.31	1601	0.44	1754	0.58	1887	0.72
1500	1300	0.24	1471	0.34	1644	0.48	1798	0.62	1932	0.77
1600	1366	0.27	1524	0.38	1688	0.51	1841	0.67	1976	0.82
1700	1433	0.31	1579	0.42	1734	0.56	1884	0.71	2020	0.88
1800	1501	0.36	1637	0.47	1783	0.60	1928	0.76	2063	0.93
1900	1570	0.41	1698	0.52	1834	0.66	1973	0.82	2106	0.99
2000	1640	0.47	1761	0.58	1888	0.71	2020	0.88	2150	1.06

CFM	AVAILABLE EXTERNAL STATIC PRESSURE (in. wg)									
	1.2		1.4		1.6		1.8		2.0	
	RPM	BHP	RPM	BHP	RPM	BHP	RPM	BHP	RPM	BHP
1200	1931	0.78	2061	0.95	2200	1.15	2363	1.43	2617	1.94
1300	1967	0.82	2087	0.98	2207	1.16	2332	1.37	2471	1.62
1400	2009	0.87	2123	1.03	2234	1.20	2345	1.38	2460	1.60
1500	2052	0.93	2164	1.09	2271	1.25	2375	1.43	2478	1.63
1600	2097	0.99	2208	1.15	2312	1.32	2412	1.50	2510	1.69
1700	2141	1.05	2252	1.22	2356	1.39	2454	1.58	2548	1.76
1800	2185	1.11	2297	1.29	2400	1.47	2497	1.66	2590	1.85
1900	2229	1.18	2341	1.36	2445	1.55	2542	1.75	2634	1.94
2000	2272	1.25	2385	1.44	2489	1.64	2586	1.84	—	—

Standard Static 1115-1900 RPM, 0.72 Max BHP

Medium Static 1115-2170 RPM, 1.06 Max BHP

High Static 1115-2660 RPM, 1.96 Max BHP

## RAV048 THREE PHASE – STANDARD STATIC — 4 TON VERTICAL SUPPLY (RPM - VDC)

CFM	AVAILABLE EXTERNAL STATIC PRESSURE (in. wg)									
	0.2		0.4		0.6		0.8		1.0	
	RPM	Vdc	RPM	Vdc	RPM	Vdc	RPM	Vdc	RPM	Vdc
1200	1115	5.9	1332	7.0	1513	8.0	1665	8.8	1801	9.5
1300	1174	6.2	1376	7.2	1557	8.2	1709	9.0	1843	9.7
1400	1236	6.5	1422	7.5	1601	8.4	1754	9.2	1887	9.9
1500	1300	6.8	1471	7.7	1644	8.7	1798	9.5	—	—
1600	1366	7.2	1524	8.0	1688	8.9	1841	9.7	—	—
1700	1433	7.5	1579	8.3	1734	9.1	1884	9.9	—	—
1800	1501	7.9	1637	8.6	1783	9.4	—	—	—	—
1900	1570	8.3	1698	8.9	1834	9.7	—	—	—	—
2000	1640	8.6	1761	9.3	1888	9.9	—	—	—	—

CFM	AVAILABLE EXTERNAL STATIC PRESSURE (in. wg)									
	1.2		1.4		1.6		1.8		2.0	
	RPM	Vdc	RPM	Vdc	RPM	Vdc	RPM	Vdc	RPM	Vdc
1200	—	—	—	—	—	—	—	—	—	—
1300	—	—	—	—	—	—	—	—	—	—
1400	—	—	—	—	—	—	—	—	—	—
1500	—	—	—	—	—	—	—	—	—	—
1600	—	—	—	—	—	—	—	—	—	—
1700	—	—	—	—	—	—	—	—	—	—
1800	—	—	—	—	—	—	—	—	—	—
1900	—	—	—	—	—	—	—	—	—	—
2000	—	—	—	—	—	—	—	—	—	—

Standard Static 1115-1900 RPM

**RAV048 THREE PHASE – MEDIUM STATIC — 4 TON VERTICAL SUPPLY (RPM - VDC)**

CFM	AVAILABLE EXTERNAL STATIC PRESSURE (in. wg)									
	0.2		0.4		0.6		0.8		1.0	
	RPM	Vdc	RPM	Vdc	RPM	Vdc	RPM	Vdc	RPM	Vdc
1200	1115	5.1	1332	6.1	1513	7.0	1665	7.7	1801	8.3
1300	1174	5.4	1376	6.3	1557	7.2	1709	7.9	1843	8.5
1400	1236	5.7	1422	6.6	1601	7.4	1754	8.1	1887	8.7
1500	1300	6.0	1471	6.8	1644	7.6	1798	8.3	1932	8.9
1600	1366	6.3	1524	7.0	1688	7.8	1841	8.5	1976	9.1
1700	1433	6.6	1579	7.3	1734	8.0	1884	8.7	2020	9.3
1800	1501	6.9	1637	7.5	1783	8.2	1928	8.9	2063	9.5
1900	1570	7.2	1698	7.8	1834	8.5	1973	9.1	2106	9.7
2000	1640	7.6	1761	8.1	1888	8.7	2020	9.3	2150	9.9

CFM	AVAILABLE EXTERNAL STATIC PRESSURE (in. wg)									
	1.2		1.4		1.6		1.8		2.0	
	RPM	Vdc	RPM	Vdc	RPM	Vdc	RPM	Vdc	RPM	Vdc
1200	1931	8.9	2061	9.5	—	—	—	—	—	—
1300	1967	9.1	2087	9.6	—	—	—	—	—	—
1400	2009	9.3	2123	9.8	—	—	—	—	—	—
1500	2052	9.5	—	—	—	—	—	—	—	—
1600	2097	9.7	—	—	—	—	—	—	—	—
1700	2141	9.9	—	—	—	—	—	—	—	—
1800	—	—	—	—	—	—	—	—	—	—
1900	—	—	—	—	—	—	—	—	—	—
2000	—	—	—	—	—	—	—	—	—	—

Medium Static 1115-2170 RPM

**RAV048 THREE PHASE – HIGH STATIC — 4 TON VERTICAL SUPPLY (RPM - VDC)**

CFM	AVAILABLE EXTERNAL STATIC PRESSURE (in. wg)									
	0.2		0.4		0.6		0.8		1.0	
	RPM	Vdc	RPM	Vdc	RPM	Vdc	RPM	Vdc	RPM	Vdc
1200	1115	4.2	1332	5.0	1513	5.7	1665	6.3	1801	6.8
1300	1174	4.4	1376	5.2	1557	5.9	1709	6.4	1843	6.9
1400	1236	4.6	1422	5.3	1601	6.0	1754	6.6	1887	7.1
1500	1300	4.9	1471	5.5	1644	6.2	1798	6.8	1932	7.3
1600	1366	5.1	1524	5.7	1688	6.3	1841	6.9	1976	7.4
1700	1433	5.4	1579	5.9	1734	6.5	1884	7.1	2020	7.6
1800	1501	5.6	1637	6.2	1783	6.7	1928	7.2	2063	7.8
1900	1570	5.9	1698	6.4	1834	6.9	1973	7.4	2106	7.9
2000	1640	6.2	1761	6.6	1888	7.1	2020	7.6	2150	8.1

CFM	AVAILABLE EXTERNAL STATIC PRESSURE (in. wg)									
	1.2		1.4		1.6		1.8		2.0	
	RPM	Vdc	RPM	Vdc	RPM	Vdc	RPM	Vdc	RPM	Vdc
1200	1931	7.3	2061	7.7	2200	8.3	2363	8.9	2617	9.8
1300	1967	7.4	2087	7.8	2207	8.3	2332	8.8	2471	9.3
1400	2009	7.6	2123	8.0	2234	8.4	2345	8.8	2460	9.2
1500	2052	7.7	2164	8.1	2271	8.5	2375	8.9	2478	9.3
1600	2097	7.9	2208	8.3	2312	8.7	2412	9.1	2510	9.4
1700	2141	8.0	2252	8.5	2356	8.9	2454	9.2	2548	9.6
1800	2185	8.2	2297	8.6	2400	9.0	2497	9.4	2590	9.7
1900	2229	8.4	2341	8.8	2445	9.2	2542	9.6	2634	9.9
2000	2272	8.5	2385	9.0	2489	9.4	2586	9.7	—	—

High Static 1115-2660 RPM

# Fan data (cont)

## RAV060 SINGLE PHASE — 5 TON VERTICAL SUPPLY (RPM - BHP)

CFM	AVAILABLE EXTERNAL STATIC PRESSURE (in. wg)									
	0.2		0.4		0.6		0.8		1.0	
	RPM	BHP	RPM	BHP	RPM	BHP	RPM	BHP	RPM	BHP
1500	1301	0.24	1476	0.35	1639	0.47	1788	0.62	1925	0.77
1625	1381	0.28	1545	0.40	1700	0.53	1843	0.67	1976	0.83
1750	1463	0.34	1615	0.45	1763	0.59	1901	0.74	2031	0.90
1875	1548	0.40	1688	0.51	1828	0.65	1962	0.81	2087	0.97
2000	1633	0.46	1764	0.59	1897	0.73	2025	0.89	2146	1.05
2125	1720	0.54	1842	0.67	1967	0.81	2090	0.97	2208	1.15
2250	1808	0.63	1922	0.75	2040	0.90	2157	1.07	2271	1.24
2375	1897	0.72	2003	0.85	2115	1.00	2227	1.17	2336	1.35
2500	1987	0.83	2086	0.96	2191	1.11	2298	1.28	—	—

CFM	AVAILABLE EXTERNAL STATIC PRESSURE (in. wg)									
	1.2		1.4		1.6		1.8		2.0	
	RPM	BHP	RPM	BHP	RPM	BHP	RPM	BHP	RPM	BHP
1500	2053	0.93	2174	1.11	2289	1.29	—	—	—	—
1625	2101	1.00	2220	1.18	2332	1.36	—	—	—	—
1750	2152	1.07	2268	1.25	2378	1.44	—	—	—	—
1875	2206	1.15	2318	1.33	—	—	—	—	—	—
2000	2262	1.23	2372	1.42	—	—	—	—	—	—
2125	2320	1.33	—	—	—	—	—	—	—	—
2250	2380	1.43	—	—	—	—	—	—	—	—
2375	—	—	—	—	—	—	—	—	—	—
2500	—	—	—	—	—	—	—	—	—	—

Standard Static 1301-2150 RPM, 1.06 Max BHP

Medium Static 1301-2390 RPM, 1.44 Max BHP

## RAV060 SINGLE PHASE – STANDARD STATIC — 5 TON VERTICAL SUPPLY (RPM - VDC)

CFM	AVAILABLE EXTERNAL STATIC PRESSURE (in. wg)									
	0.2		0.4		0.6		0.8		1.0	
	RPM	Vdc	RPM	Vdc	RPM	Vdc	RPM	Vdc	RPM	Vdc
1500	1301	6.1	1476	6.9	1639	7.6	1788	8.3	1925	9.0
1625	1381	6.4	1545	7.2	1700	7.9	1843	8.6	1976	9.2
1750	1463	6.8	1615	7.5	1763	8.2	1901	8.8	2031	9.4
1875	1548	7.2	1688	7.9	1828	8.5	1962	9.1	2087	9.7
2000	1633	7.6	1764	8.2	1897	8.8	2025	9.4	2146	10.0
2125	1720	8.0	1842	8.6	1967	9.1	2090	9.7	—	—
2250	1808	8.4	1922	8.9	2040	9.5	—	—	—	—
2375	1897	8.8	2003	9.3	2115	9.8	—	—	—	—
2500	1987	9.2	2086	9.7	—	—	—	—	—	—

CFM	AVAILABLE EXTERNAL STATIC PRESSURE (in. wg)									
	1.2		1.4		1.6		1.8		2.0	
	RPM	Vdc	RPM	Vdc	RPM	Vdc	RPM	Vdc	RPM	Vdc
1500	2053	9.5	—	—	—	—	—	—	—	—
1625	2101	9.8	—	—	—	—	—	—	—	—
1750	—	—	—	—	—	—	—	—	—	—
1875	—	—	—	—	—	—	—	—	—	—
2000	—	—	—	—	—	—	—	—	—	—
2125	—	—	—	—	—	—	—	—	—	—
2250	—	—	—	—	—	—	—	—	—	—
2375	—	—	—	—	—	—	—	—	—	—
2500	—	—	—	—	—	—	—	—	—	—

Standard Static 1301-2150 RPM

**RAV060 SINGLE PHASE – MEDIUM STATIC — 3 TON VERTICAL SUPPLY (RPM - VDC)**

CFM	AVAILABLE EXTERNAL STATIC PRESSURE (in. wg)									
	0.2		0.4		0.6		0.8		1.0	
	RPM	Vdc	RPM	Vdc	RPM	Vdc	RPM	Vdc	RPM	Vdc
1500	1301	5.4	1476	6.2	1639	6.9	1788	7.5	1925	8.1
1625	1381	5.8	1545	6.5	1700	7.1	1843	7.7	1976	8.3
1750	1463	6.1	1615	6.8	1763	7.4	1901	8.0	2031	8.5
1875	1548	6.5	1688	7.1	1828	7.6	1962	8.2	2087	8.7
2000	1633	6.8	1764	7.4	1897	7.9	2025	8.5	2146	9.0
2125	1720	7.2	1842	7.7	1967	8.2	2090	8.7	2208	9.2
2250	1808	7.6	1922	8.0	2040	8.5	2157	9.0	2271	9.5
2375	1897	7.9	2003	8.4	2115	8.8	2227	9.3	2336	9.8
2500	1987	8.3	2086	8.7	2191	9.2	2298	9.6	—	—

CFM	AVAILABLE EXTERNAL STATIC PRESSURE (in. wg)									
	1.2		1.4		1.6		1.8		2.0	
	RPM	Vdc	RPM	Vdc	RPM	Vdc	RPM	Vdc	RPM	Vdc
1500	2053	8.6	2174	9.1	2289	9.6	—	—	—	—
1625	2101	8.8	2220	9.3	2332	9.8	—	—	—	—
1750	2152	9.0	2268	9.5	2378	9.9	—	—	—	—
1875	2206	9.2	2318	9.7	—	—	—	—	—	—
2000	2262	9.5	2372	9.9	—	—	—	—	—	—
2125	2320	9.7	—	—	—	—	—	—	—	—
2250	2380	10.0	—	—	—	—	—	—	—	—
2375	—	—	—	—	—	—	—	—	—	—
2500	—	—	—	—	—	—	—	—	—	—

Medium Static 1301-2390 RPM

**RAV060 THREE PHASE — 5 TON VERTICAL SUPPLY (RPM - BHP)**

CFM	AVAILABLE EXTERNAL STATIC PRESSURE (in. wg)									
	0.2		0.4		0.6		0.8		1.0	
	RPM	BHP	RPM	BHP	RPM	BHP	RPM	BHP	RPM	BHP
1500	1301	0.24	1477	0.35	1639	0.47	1788	0.62	1925	0.77
1625	1381	0.28	1545	0.40	1700	0.53	1843	0.67	1977	0.83
1750	1463	0.34	1615	0.45	1763	0.59	1902	0.74	2031	0.90
1875	1548	0.40	1688	0.51	1829	0.65	1962	0.81	2088	0.97
2000	1633	0.46	1764	0.59	1897	0.73	2025	0.89	2147	1.06
2125	1720	0.54	1842	0.67	1968	0.81	2090	0.97	2208	1.15
2250	1809	0.63	1922	0.75	2040	0.90	2158	1.07	2271	1.24
2375	1897	0.72	2003	0.85	2115	1.00	2227	1.17	2336	1.35
2500	1987	0.83	2086	0.96	2192	1.12	2299	1.29	2403	1.47

CFM	AVAILABLE EXTERNAL STATIC PRESSURE (in. wg)									
	1.2		1.4		1.6		1.8		2.0	
	RPM	BHP	RPM	BHP	RPM	BHP	RPM	BHP	RPM	BHP
1500	2053	0.93	2174	1.11	2289	1.29	2398	1.49	2502	1.69
1625	2102	1.00	2220	1.18	2332	1.36	2439	1.56	2542	1.77
1750	2153	1.07	2268	1.25	2378	1.44	2483	1.64	2584	1.85
1875	2206	1.15	2319	1.33	2426	1.53	2529	1.73	2628	1.94
2000	2262	1.23	2372	1.42	2477	1.62	2578	1.83	2675	2.04
2125	2320	1.33	2427	1.52	2530	1.72	2629	1.93	2724	2.15
2250	2380	1.43	2485	1.63	2585	1.83	2682	2.05	2775	2.27
2375	2443	1.55	2544	1.75	2642	1.96	2737	2.17	2828	2.40
2500	2506	1.67	2605	1.87	2701	2.09	2794	2.31	—	—

Standard Static 1301-2150 RPM, 1.06 Max BHP

Medium Static 1301-2390 RPM, 1.44 Max BHP

High Static 1301-2836 RPM, 2.43 Max BHP

# Fan data (cont)

## RAV060 THREE PHASE – STANDARD STATIC — 5 TON VERTICAL SUPPLY (RPM - VDC)

CFM	AVAILABLE EXTERNAL STATIC PRESSURE (in. wg)									
	0.2		0.4		0.6		0.8		1.0	
	RPM	Vdc	RPM	Vdc	RPM	Vdc	RPM	Vdc	RPM	Vdc
1500	1301	6.1	1477	6.9	1639	7.6	1788	8.3	1925	9.0
1625	1381	6.4	1545	7.2	1700	7.9	1843	8.6	1977	9.2
1750	1463	6.8	1615	7.5	1763	8.2	1902	8.8	2031	9.4
1875	1548	7.2	1688	7.9	1829	8.5	1962	9.1	2088	9.7
2000	1633	7.6	1764	8.2	1897	8.8	2025	9.4	2147	10.0
2125	1720	8.0	1842	8.6	1968	9.2	2090	9.7	—	—
2250	1809	8.4	1922	8.9	2040	9.5	—	—	—	—
2375	1897	8.8	2003	9.3	2115	9.8	—	—	—	—
2500	1987	9.2	2086	9.7	—	—	—	—	—	—

CFM	AVAILABLE EXTERNAL STATIC PRESSURE (in. wg)									
	1.2		1.4		1.6		1.8		2.0	
	RPM	Vdc	RPM	Vdc	RPM	Vdc	RPM	Vdc	RPM	Vdc
1500	2053	9.5	—	—	—	—	—	—	—	—
1625	2102	9.8	—	—	—	—	—	—	—	—
1750	—	—	—	—	—	—	—	—	—	—
1875	—	—	—	—	—	—	—	—	—	—
2000	—	—	—	—	—	—	—	—	—	—
2125	—	—	—	—	—	—	—	—	—	—
2250	—	—	—	—	—	—	—	—	—	—
2375	—	—	—	—	—	—	—	—	—	—
2500	—	—	—	—	—	—	—	—	—	—

Standard Static 1301-2150 RPM

## RAV060 THREE PHASE – MEDIUM STATIC — 5 TON VERTICAL SUPPLY (RPM - VDC)

CFM	AVAILABLE EXTERNAL STATIC PRESSURE (in. wg)									
	0.2		0.4		0.6		0.8		1.0	
	RPM	Vdc	RPM	Vdc	RPM	Vdc	RPM	Vdc	RPM	Vdc
1500	1301	5.4	1477	6.2	1639	6.9	1788	7.5	1925	8.1
1625	1381	5.8	1545	6.5	1700	7.1	1843	7.7	1977	8.3
1750	1463	6.1	1615	6.8	1763	7.4	1902	8.0	2031	8.5
1875	1548	6.5	1688	7.1	1829	7.7	1962	8.2	2088	8.7
2000	1633	6.8	1764	7.4	1897	7.9	2025	8.5	2147	9.0
2125	1720	7.2	1842	7.7	1968	8.2	2090	8.7	2208	9.2
2250	1809	7.6	1922	8.0	2040	8.5	2158	9.0	2271	9.5
2375	1897	7.9	2003	8.4	2115	8.8	2227	9.3	2336	9.8
2500	1987	8.3	2086	8.7	2192	9.2	2299	9.6	—	—

CFM	AVAILABLE EXTERNAL STATIC PRESSURE (in. wg)									
	1.2		1.4		1.6		1.8		2.0	
	RPM	Vdc	RPM	Vdc	RPM	Vdc	RPM	Vdc	RPM	Vdc
1500	2053	8.6	2174	9.1	2289	9.6	—	—	—	—
1625	2102	8.8	2220	9.3	2332	9.8	—	—	—	—
1750	2153	9.0	2268	9.5	2378	9.9	—	—	—	—
1875	2206	9.2	2319	9.7	—	—	—	—	—	—
2000	2262	9.5	2372	9.9	—	—	—	—	—	—
2125	2320	9.7	—	—	—	—	—	—	—	—
2250	2380	10.0	—	—	—	—	—	—	—	—
2375	—	—	—	—	—	—	—	—	—	—
2500	—	—	—	—	—	—	—	—	—	—

Medium Static 1301-2390 RPM

**RAV060 THREE PHASE – HIGH STATIC – 5 TON VERTICAL SUPPLY (RPM - VDC)**

CFM	AVAILABLE EXTERNAL STATIC PRESSURE (in. wg)									
	0.2		0.4		0.6		0.8		1.0	
	RPM	Vdc	RPM	Vdc	RPM	Vdc	RPM	Vdc	RPM	Vdc
1500	1301	4.6	1477	5.2	1639	5.8	1788	6.3	1925	6.8
1625	1381	4.9	1545	5.4	1700	6.0	1843	6.5	1977	7.0
1750	1463	5.2	1615	5.7	1763	6.2	1902	6.7	2031	7.2
1875	1548	5.5	1688	6.0	1829	6.4	1962	6.9	2088	7.4
2000	1633	5.8	1764	6.2	1897	6.7	2025	7.1	2147	7.6
2125	1720	6.1	1842	6.5	1968	6.9	2090	7.4	2208	7.8
2250	1809	6.4	1922	6.8	2040	7.2	2158	7.6	2271	8.0
2375	1897	6.7	2003	7.1	2115	7.5	2227	7.9	2336	8.2
2500	1987	7.0	2086	7.4	2192	7.7	2299	8.1	2403	8.5

CFM	AVAILABLE EXTERNAL STATIC PRESSURE (in. wg)									
	1.2		1.4		1.6		1.8		2.0	
	RPM	Vdc	RPM	Vdc	RPM	Vdc	RPM	Vdc	RPM	Vdc
1500	2053	7.2	2174	7.7	2289	8.1	2398	8.5	2502	8.8
1625	2102	7.4	2220	7.8	2332	8.2	2439	8.6	2542	9.0
1750	2153	7.6	2268	8.0	2378	8.4	2483	8.8	2584	9.1
1875	2206	7.8	2319	8.2	2426	8.6	2529	8.9	2628	9.3
2000	2262	8.0	2372	8.4	2477	8.7	2578	9.1	2675	9.4
2125	2320	8.2	2427	8.6	2530	8.9	2629	9.3	2724	9.6
2250	2380	8.4	2485	8.8	2585	9.1	2682	9.5	2775	9.8
2375	2443	8.6	2544	9.0	2642	9.3	2737	9.7	2828	10.0
2500	2506	8.8	2605	9.2	2701	9.5	2794	9.9	—	—

High Static 1301-2836 RPM

**RAV072 THREE PHASE – 6 TON VERTICAL SUPPLY (RPM - BHP)**

CFM	AVAILABLE EXTERNAL STATIC PRESSURE (in. wg)									
	0.2		0.4		0.6		0.8		1.0	
	RPM	BHP	RPM	BHP	RPM	BHP	RPM	BHP	RPM	BHP
1800	1423	0.30	1550	0.39	1682	0.50	1820	0.64	1955	0.79
1950	1521	0.37	1638	0.46	1758	0.57	1883	0.70	2011	0.86
2100	1620	0.45	1730	0.54	1839	0.65	1953	0.78	2071	0.93
2250	1720	0.53	1824	0.64	1924	0.75	2029	0.88	2137	1.02
2400	1820	0.63	1919	0.74	2013	0.85	2109	0.98	2209	1.13
2550	1921	0.74	2016	0.86	2105	0.98	2194	1.11	2286	1.25
2700	2022	0.86	2113	0.99	2198	1.11	2282	1.24	2368	1.39
2850	2123	1.00	2212	1.13	2293	1.26	2373	1.40	2453	1.54
3000	2225	1.15	2311	1.29	2389	1.42	2465	1.56	2541	1.71

CFM	AVAILABLE EXTERNAL STATIC PRESSURE (in. wg)									
	1.2		1.4		1.6		1.8		2.0	
	RPM	BHP	RPM	BHP	RPM	BHP	RPM	BHP	RPM	BHP
1800	2079	0.95	2192	1.11	2296	1.28	2393	1.45	2485	1.62
1950	2133	1.02	2247	1.19	2353	1.37	2451	1.55	2543	1.73
2100	2189	1.10	2301	1.28	2408	1.47	2507	1.66	2601	1.85
2250	2248	1.19	2357	1.37	2462	1.57	2562	1.76	2656	1.97
2400	2312	1.30	2416	1.48	2517	1.67	2616	1.88	2711	2.09
2550	2381	1.41	2479	1.60	2576	1.79	2672	2.00	2765	2.21
2700	2456	1.55	2546	1.73	2638	1.92	2730	2.13	2821	2.35
2850	2535	1.70	2619	1.88	2705	2.07	2793	2.28	—	—
3000	2618	1.87	2696	2.05	2777	2.24	—	—	—	—

Standard Static 1423-2300 RPM, 1.31 Max BHP

Medium Static 1423-2530 RPM, 1.76 Max BHP

High Static 1423-2836 RPM, 2.43 Max BHP

# Fan data (cont)

## RAV072 THREE PHASE – STANDARD STATIC — 6 TON VERTICAL SUPPLY (RPM - VDC)

CFM	AVAILABLE EXTERNAL STATIC PRESSURE (in. wg)									
	0.2		0.4		0.6		0.8		1.0	
	RPM	Vdc	RPM	Vdc	RPM	Vdc	RPM	Vdc	RPM	Vdc
1800	1423	6.2	1550	6.7	1682	7.3	1820	7.9	1955	8.5
1950	1521	6.6	1638	7.1	1758	7.6	1883	8.2	2011	8.7
2100	1620	7.0	1730	7.5	1839	8.0	1953	8.5	2071	9.0
2250	1720	7.5	1824	7.9	1924	8.4	2029	8.8	2137	9.3
2400	1820	7.9	1919	8.3	2013	8.8	2109	9.2	2209	9.6
2550	1921	8.4	2016	8.8	2105	9.2	2194	9.5	2286	9.9
2700	2022	8.8	2113	9.2	2198	9.6	2282	9.9	—	—
2850	2123	9.2	2212	9.6	2293	10.0	—	—	—	—
3000	2225	9.7	—	—	—	—	—	—	—	—

CFM	AVAILABLE EXTERNAL STATIC PRESSURE (in. wg)									
	1.2		1.4		1.6		1.8		2.0	
	RPM	Vdc	RPM	Vdc	RPM	Vdc	RPM	Vdc	RPM	Vdc
1800	2079	9.0	2192	9.5	2296	10.0	—	—	—	—
1950	2133	9.3	2247	9.8	—	—	—	—	—	—
2100	2189	9.5	—	—	—	—	—	—	—	—
2250	2248	9.8	—	—	—	—	—	—	—	—
2400	—	—	—	—	—	—	—	—	—	—
2550	—	—	—	—	—	—	—	—	—	—
2700	—	—	—	—	—	—	—	—	—	—
2850	—	—	—	—	—	—	—	—	—	—
3000	—	—	—	—	—	—	—	—	—	—

Standard Static 1423-2300 RPM

## RAV072 THREE PHASE – MEDIUM STATIC — 6 TON VERTICAL SUPPLY (RPM - VDC)

CFM	AVAILABLE EXTERNAL STATIC PRESSURE (in. wg)									
	0.2		0.4		0.6		0.8		1.0	
	RPM	Vdc	RPM	Vdc	RPM	Vdc	RPM	Vdc	RPM	Vdc
1800	1423	5.6	1550	6.1	1682	6.6	1820	7.2	1955	7.7
1950	1521	6.0	1638	6.5	1758	6.9	1883	7.4	2011	7.9
2100	1620	6.4	1730	6.8	1839	7.3	1953	7.7	2071	8.2
2250	1720	6.8	1824	7.2	1924	7.6	2029	8.0	2137	8.4
2400	1820	7.2	1919	7.6	2013	8.0	2109	8.3	2209	8.7
2550	1921	7.6	2016	8.0	2105	8.3	2194	8.7	2286	9.0
2700	2022	8.0	2113	8.4	2198	8.7	2282	9.0	2368	9.4
2850	2123	8.4	2212	8.7	2293	9.1	2373	9.4	2453	9.7
3000	2225	8.8	2311	9.1	2389	9.4	2465	9.7	—	—

CFM	AVAILABLE EXTERNAL STATIC PRESSURE (in. wg)									
	1.2		1.4		1.6		1.8		2.0	
	RPM	Vdc	RPM	Vdc	RPM	Vdc	RPM	Vdc	RPM	Vdc
1800	2079	8.2	2192	8.7	2296	9.1	2393	9.5	2485	9.8
1950	2133	8.4	2247	8.9	2353	9.3	2451	9.7	—	—
2100	2189	8.7	2301	9.1	2408	9.5	2507	9.9	—	—
2250	2248	8.9	2357	9.3	2462	9.7	—	—	—	—
2400	2312	9.1	2416	9.5	2517	9.9	—	—	—	—
2550	2381	9.4	2479	9.8	—	—	—	—	—	—
2700	2456	9.7	—	—	—	—	—	—	—	—
2850	—	—	—	—	—	—	—	—	—	—
3000	—	—	—	—	—	—	—	—	—	—

Medium Static 1423-2530 RPM

**RAV072 THREE PHASE – HIGH STATIC — 6 TON VERTICAL SUPPLY (RPM - VDC)**

CFM	AVAILABLE EXTERNAL STATIC PRESSURE (in. wg)									
	0.2		0.4		0.6		0.8		1.0	
	RPM	Vdc	RPM	Vdc	RPM	Vdc	RPM	Vdc	RPM	Vdc
<b>1800</b>	1423	5.0	1550	5.5	1682	5.9	1820	6.4	1955	6.9
<b>1950</b>	1521	5.4	1638	5.8	1758	6.2	1883	6.6	2011	7.1
<b>2100</b>	1620	5.7	1730	6.1	1839	6.5	1953	6.9	2071	7.3
<b>2250</b>	1720	6.1	1824	6.4	1924	6.8	2029	7.2	2137	7.5
<b>2400</b>	1820	6.4	1919	6.8	2013	7.1	2109	7.4	2209	7.8
<b>2550</b>	1921	6.8	2016	7.1	2105	7.4	2194	7.7	2286	8.1
<b>2700</b>	2022	7.1	2113	7.5	2198	7.8	2282	8.0	2368	8.3
<b>2850</b>	2123	7.5	2212	7.8	2293	8.1	2373	8.4	2453	8.6
<b>3000</b>	2225	7.8	2311	8.1	2389	8.4	2465	8.7	2541	9.0

CFM	AVAILABLE EXTERNAL STATIC PRESSURE (in. wg)									
	1.2		1.4		1.6		1.8		2.0	
	RPM	Vdc	RPM	Vdc	RPM	Vdc	RPM	Vdc	RPM	Vdc
<b>1800</b>	2079	7.3	2192	7.7	2296	8.1	2393	8.4	2485	8.8
<b>1950</b>	2133	7.5	2247	7.9	2353	8.3	2451	8.6	2543	9.0
<b>2100</b>	2189	7.7	2301	8.1	2408	8.5	2507	8.8	2601	9.2
<b>2250</b>	2248	7.9	2357	8.3	2462	8.7	2562	9.0	2656	9.4
<b>2400</b>	2312	8.2	2416	8.5	2517	8.9	2616	9.2	2711	9.6
<b>2550</b>	2381	8.4	2479	8.7	2576	9.1	2672	9.4	2765	9.7
<b>2700</b>	2456	8.7	2546	9.0	2638	9.3	2730	9.6	2821	9.9
<b>2850</b>	2535	8.9	2619	9.2	2705	9.5	2793	9.8	—	—
<b>3000</b>	2618	9.2	2696	9.5	2777	9.8	—	—	—	—

High Static 1423-2836 RPM

# Fan data (cont)

## RAV036 SINGLE PHASE — 3 TON HORIZONTAL SUPPLY (RPM - BHP)

CFM	AVAILABLE EXTERNAL STATIC PRESSURE (in. wg)									
	0.2		0.4		0.6		0.8		1.0	
	RPM	BHP	RPM	BHP	RPM	BHP	RPM	BHP	RPM	BHP
900	1017	0.07	1284	0.15	1501	0.24	1684	0.33	1843	0.44
975	1055	0.08	1311	0.16	1527	0.25	1711	0.35	1871	0.46
1050	1096	0.09	1340	0.17	1553	0.26	1737	0.36	1899	0.48
1125	1140	0.10	1371	0.18	1580	0.27	1763	0.38	1925	0.50
1200	1186	0.12	1404	0.19	1608	0.29	1789	0.40	1951	0.52
1275	1236	0.13	1440	0.21	1637	0.31	1816	0.42	1977	0.54
1350	1286	0.15	1477	0.22	1666	0.32	1843	0.44	2004	0.56
1425	1338	0.17	1517	0.24	1698	0.34	1871	0.46	2030	0.58
1500	1391	0.19	1559	0.26	1733	0.36	1900	0.48	2057	0.61

CFM	AVAILABLE EXTERNAL STATIC PRESSURE (in. wg)									
	1.2		1.4		1.6		1.8		2.0	
	RPM	BHP	RPM	BHP	RPM	BHP	RPM	BHP	RPM	BHP
900	1984	0.54	2113	0.66	2231	0.77	2342	0.89	2446	1.02
975	2014	0.57	2144	0.69	2264	0.81	2376	0.93	2481	1.06
1050	2043	0.59	2174	0.72	2295	0.84	2408	0.97	—	—
1125	2071	0.62	2203	0.74	2325	0.88	2439	1.01	—	—
1200	2098	0.64	2231	0.77	2354	0.91	2469	1.05	—	—
1275	2124	0.67	2258	0.80	2382	0.94	—	—	—	—
1350	2150	0.69	2285	0.83	2410	0.97	—	—	—	—
1425	2176	0.72	2311	0.86	2436	1.01	—	—	—	—
1500	2202	0.74	2337	0.89	2462	1.04	—	—	—	—

Standard Static 1017-1890 RPM, 0.44 Max BHP

Medium Static 1017-2190 RPM, 0.71 Max BHP

High Static 1017-2490 RPM, 1.07 Max BHP

## RAV036 SINGLE PHASE – STANDARD STATIC — 3 TON HORIZONTAL SUPPLY (RPM - VDC)

CFM	AVAILABLE EXTERNAL STATIC PRESSURE (in. wg)									
	0.2		0.4		0.6		0.8		1.0	
	RPM	Vdc	RPM	Vdc	RPM	Vdc	RPM	Vdc	RPM	Vdc
900	1017	5.4	1284	6.8	1501	7.9	1684	8.9	1843	9.8
975	1055	5.6	1311	6.9	1527	8.1	1711	9.1	—	—
1050	1096	5.8	1340	7.1	1553	8.2	1737	9.2	—	—
1125	1140	6.0	1371	7.3	1580	8.4	1763	9.3	—	—
1200	1186	6.3	1404	7.4	1608	8.5	1789	9.5	—	—
1275	1236	6.5	1440	7.6	1637	8.7	1816	9.6	—	—
1350	1286	6.8	1477	7.8	1666	8.8	1843	9.8	—	—
1425	1338	7.1	1517	8.0	1698	9.0	—	—	—	—
1500	1391	7.4	1559	8.2	1733	9.2	—	—	—	—

CFM	AVAILABLE EXTERNAL STATIC PRESSURE (in. wg)									
	1.2		1.4		1.6		1.8		2.0	
	RPM	Vdc	RPM	Vdc	RPM	Vdc	RPM	Vdc	RPM	Vdc
900	—	—	—	—	—	—	—	—	—	—
975	—	—	—	—	—	—	—	—	—	—
1050	—	—	—	—	—	—	—	—	—	—
1125	—	—	—	—	—	—	—	—	—	—
1200	—	—	—	—	—	—	—	—	—	—
1275	—	—	—	—	—	—	—	—	—	—
1350	—	—	—	—	—	—	—	—	—	—
1425	—	—	—	—	—	—	—	—	—	—
1500	—	—	—	—	—	—	—	—	—	—

Standard Static 1017-1890 RPM

**RAV036 SINGLE PHASE – MEDIUM STATIC — 3 TON HORIZONTAL SUPPLY (RPM - VDC)**

CFM	AVAILABLE EXTERNAL STATIC PRESSURE (in. wg)									
	0.2		0.4		0.6		0.8		1.0	
	RPM	Vdc	RPM	Vdc	RPM	Vdc	RPM	Vdc	RPM	Vdc
900	1017	4.6	1284	5.9	1501	6.9	1684	7.7	1843	8.4
975	1055	4.8	1311	6.0	1527	7.0	1711	7.8	1871	8.5
1050	1096	5.0	1340	6.1	1553	7.1	1737	7.9	1899	8.7
1125	1140	5.2	1371	6.3	1580	7.2	1763	8.1	1925	8.8
1200	1186	5.4	1404	6.4	1608	7.3	1789	8.2	1951	8.9
1275	1236	5.6	1440	6.6	1637	7.5	1816	8.3	1977	9.0
1350	1286	5.9	1477	6.7	1666	7.6	1843	8.4	2004	9.2
1425	1338	6.1	1517	6.9	1698	7.8	1871	8.5	2030	9.3
1500	1391	6.4	1559	7.1	1733	7.9	1900	8.7	2057	9.4

CFM	AVAILABLE EXTERNAL STATIC PRESSURE (in. wg)									
	1.2		1.4		1.6		1.8		2.0	
	RPM	Vdc	RPM	Vdc	RPM	Vdc	RPM	Vdc	RPM	Vdc
900	1984	9.1	2113	9.6	—	—	—	—	—	—
975	2014	9.2	2144	9.8	—	—	—	—	—	—
1050	2043	9.3	—	—	—	—	—	—	—	—
1125	2071	9.5	—	—	—	—	—	—	—	—
1200	2098	9.6	—	—	—	—	—	—	—	—
1275	2124	9.7	—	—	—	—	—	—	—	—
1350	2150	9.8	—	—	—	—	—	—	—	—
1425	—	—	—	—	—	—	—	—	—	—
1500	—	—	—	—	—	—	—	—	—	—

Medium Static 1017-2190 RPM

**RAV036 SINGLE PHASE – HIGH STATIC — 3 TON HORIZONTAL SUPPLY (RPM - VDC)**

CFM	AVAILABLE EXTERNAL STATIC PRESSURE (in. wg)									
	0.2		0.4		0.6		0.8		1.0	
	RPM	Vdc	RPM	Vdc	RPM	Vdc	RPM	Vdc	RPM	Vdc
900	1017	4.1	1284	5.2	1501	6.0	1684	6.8	1843	7.4
975	1055	4.2	1311	5.3	1527	6.1	1711	6.9	1871	7.5
1050	1096	4.4	1340	5.4	1553	6.2	1737	7.0	1899	7.6
1125	1140	4.6	1371	5.5	1580	6.3	1763	7.1	1925	7.7
1200	1186	4.8	1404	5.6	1608	6.5	1789	7.2	1951	7.8
1275	1236	5.0	1440	5.8	1637	6.6	1816	7.3	1977	7.9
1350	1286	5.2	1477	5.9	1666	6.7	1843	7.4	2004	8.0
1425	1338	5.4	1517	6.1	1698	6.8	1871	7.5	2030	8.2
1500	1391	5.6	1559	6.3	1733	7.0	1900	7.6	2057	8.3

CFM	AVAILABLE EXTERNAL STATIC PRESSURE (in. wg)									
	1.2		1.4		1.6		1.8		2.0	
	RPM	Vdc	RPM	Vdc	RPM	Vdc	RPM	Vdc	RPM	Vdc
900	1984	8.0	2113	8.5	2231	9.0	2342	9.4	2446	9.8
975	2014	8.1	2144	8.6	2264	9.1	2376	9.5	2481	10.0
1050	2043	8.2	2174	8.7	2295	9.2	2408	9.7	—	—
1125	2071	8.3	2203	8.8	2325	9.3	2439	9.8	—	—
1200	2098	8.4	2231	9.0	2354	9.5	2469	9.9	—	—
1275	2124	8.5	2258	9.1	2382	9.6	—	—	—	—
1350	2150	8.6	2285	9.2	2410	9.7	—	—	—	—
1425	2176	8.7	2311	9.3	2436	9.8	—	—	—	—
1500	2202	8.8	2337	9.4	2462	9.9	—	—	—	—

High Static 1017-2490 RPM

# Fan data (cont)

## RAV036 THREE PHASE — 3 TON HORIZONTAL SUPPLY (RPM - BHP)

CFM	AVAILABLE EXTERNAL STATIC PRESSURE (in. wg)									
	0.2		0.4		0.6		0.8		1.0	
	RPM	BHP	RPM	BHP	RPM	BHP	RPM	BHP	RPM	BHP
900	1017	0.07	1284	0.15	1501	0.24	1684	0.33	1843	0.44
975	1055	0.08	1311	0.16	1527	0.25	1711	0.35	1871	0.46
1050	1096	0.09	1340	0.17	1553	0.26	1737	0.36	1899	0.48
1125	1140	0.10	1371	0.18	1580	0.27	1763	0.38	1925	0.50
1200	1186	0.12	1404	0.19	1608	0.29	1789	0.40	1951	0.52
1275	1236	0.13	1440	0.21	1637	0.31	1816	0.42	1977	0.54
1350	1286	0.15	1477	0.22	1666	0.32	1843	0.44	2004	0.56
1425	1338	0.17	1517	0.24	1698	0.34	1871	0.46	2030	0.58
1500	1391	0.19	1559	0.26	1733	0.36	1900	0.48	2057	0.61

CFM	AVAILABLE EXTERNAL STATIC PRESSURE (in. wg)									
	1.2		1.4		1.6		1.8		2.0	
	RPM	BHP	RPM	BHP	RPM	BHP	RPM	BHP	RPM	BHP
900	1984	0.54	2113	0.66	2231	0.77	2342	0.89	2446	1.02
975	2014	0.57	2144	0.69	2264	0.81	2376	0.93	2481	1.06
1050	2043	0.59	2174	0.72	2295	0.84	2408	0.97	—	—
1125	2071	0.62	2203	0.74	2325	0.88	2439	1.01	—	—
1200	2098	0.64	2231	0.77	2354	0.91	2469	1.05	—	—
1275	2124	0.67	2258	0.80	2382	0.94	—	—	—	—
1350	2150	0.69	2285	0.83	2410	0.97	—	—	—	—
1425	2176	0.72	2311	0.86	2436	1.01	—	—	—	—
1500	2202	0.74	2337	0.89	2462	1.04	—	—	—	—

Standard Static 1017-1890 RPM, 0.44 Max BHP

Medium Static 1017-2190 RPM, 0.71 Max BHP

High Static 1017-2490 RPM, 1.07 Max BHP

## RAV036 THREE PHASE – STANDARD STATIC — 3 TON HORIZONTAL SUPPLY (RPM - VDC)

CFM	AVAILABLE EXTERNAL STATIC PRESSURE (in. wg)									
	0.2		0.4		0.6		0.8		1.0	
	RPM	Vdc	RPM	Vdc	RPM	Vdc	RPM	Vdc	RPM	Vdc
900	1017	5.4	1284	6.8	1501	7.9	1684	8.9	1843	9.8
975	1055	5.6	1311	6.9	1527	8.1	1711	9.1	—	—
1050	1096	5.8	1340	7.1	1553	8.2	1737	9.2	—	—
1125	1140	6.0	1371	7.3	1580	8.4	1763	9.3	—	—
1200	1186	6.3	1404	7.4	1608	8.5	1789	9.5	—	—
1275	1236	6.5	1440	7.6	1637	8.7	1816	9.6	—	—
1350	1286	6.8	1477	7.8	1666	8.8	1843	9.8	—	—
1425	1338	7.1	1517	8.0	1698	9.0	—	—	—	—
1500	1391	7.4	1559	8.2	1733	9.2	—	—	—	—

CFM	AVAILABLE EXTERNAL STATIC PRESSURE (in. wg)									
	1.2		1.4		1.6		1.8		2.0	
	RPM	Vdc	RPM	Vdc	RPM	Vdc	RPM	Vdc	RPM	Vdc
900	—	—	—	—	—	—	—	—	—	—
975	—	—	—	—	—	—	—	—	—	—
1050	—	—	—	—	—	—	—	—	—	—
1125	—	—	—	—	—	—	—	—	—	—
1200	—	—	—	—	—	—	—	—	—	—
1275	—	—	—	—	—	—	—	—	—	—
1350	—	—	—	—	—	—	—	—	—	—
1425	—	—	—	—	—	—	—	—	—	—
1500	—	—	—	—	—	—	—	—	—	—

Standard Static 1017-1890 RPM

**RAV036 THREE PHASE – MEDIUM STATIC — 3 TON HORIZONTAL SUPPLY (RPM - VDC)**

CFM	AVAILABLE EXTERNAL STATIC PRESSURE (in. wg)									
	0.2		0.4		0.6		0.8		1.0	
	RPM	Vdc	RPM	Vdc	RPM	Vdc	RPM	Vdc	RPM	Vdc
900	1017	4.6	1284	5.9	1501	6.9	1684	7.7	1843	8.4
975	1055	4.8	1311	6.0	1527	7.0	1711	7.8	1871	8.5
1050	1096	5.0	1340	6.1	1553	7.1	1737	7.9	1899	8.7
1125	1140	5.2	1371	6.3	1580	7.2	1763	8.1	1925	8.8
1200	1186	5.4	1404	6.4	1608	7.3	1789	8.2	1951	8.9
1275	1236	5.6	1440	6.6	1637	7.5	1816	8.3	1977	9.0
1350	1286	5.9	1477	6.7	1666	7.6	1843	8.4	2004	9.2
1425	1338	6.1	1517	6.9	1698	7.8	1871	8.5	2030	9.3
1500	1391	6.4	1559	7.1	1733	7.9	1900	8.7	2057	9.4

CFM	AVAILABLE EXTERNAL STATIC PRESSURE (in. wg)									
	1.2		1.4		1.6		1.8		2.0	
	RPM	Vdc	RPM	Vdc	RPM	Vdc	RPM	Vdc	RPM	Vdc
900	1984	9.1	2113	9.6	—	—	—	—	—	—
975	2014	9.2	2144	9.8	—	—	—	—	—	—
1050	2043	9.3	—	—	—	—	—	—	—	—
1125	2071	9.5	—	—	—	—	—	—	—	—
1200	2098	9.6	—	—	—	—	—	—	—	—
1275	2124	9.7	—	—	—	—	—	—	—	—
1350	2150	9.8	—	—	—	—	—	—	—	—
1425	—	—	—	—	—	—	—	—	—	—
1500	—	—	—	—	—	—	—	—	—	—

Medium Static 1017-2190 RPM

**RAV036 THREE PHASE – HIGH STATIC — 3 TON HORIZONTAL SUPPLY (RPM - VDC)**

CFM	AVAILABLE EXTERNAL STATIC PRESSURE (in. wg)									
	0.2		0.4		0.6		0.8		1.0	
	RPM	Vdc	RPM	Vdc	RPM	Vdc	RPM	Vdc	RPM	Vdc
900	1017	4.1	1284	5.2	1501	6.0	1684	6.8	1843	7.4
975	1055	4.2	1311	5.3	1527	6.1	1711	6.9	1871	7.5
1050	1096	4.4	1340	5.4	1553	6.2	1737	7.0	1899	7.6
1125	1140	4.6	1371	5.5	1580	6.3	1763	7.1	1925	7.7
1200	1186	4.8	1404	5.6	1608	6.5	1789	7.2	1951	7.8
1275	1236	5.0	1440	5.8	1637	6.6	1816	7.3	1977	7.9
1350	1286	5.2	1477	5.9	1666	6.7	1843	7.4	2004	8.0
1425	1338	5.4	1517	6.1	1698	6.8	1871	7.5	2030	8.2
1500	1391	5.6	1559	6.3	1733	7.0	1900	7.6	2057	8.3

CFM	AVAILABLE EXTERNAL STATIC PRESSURE (in. wg)									
	1.2		1.4		1.6		1.8		2.0	
	RPM	Vdc	RPM	Vdc	RPM	Vdc	RPM	Vdc	RPM	Vdc
900	1984	8.0	2113	8.5	2231	9.0	2342	9.4	2446	9.8
975	2014	8.1	2144	8.6	2264	9.1	2376	9.5	2481	10.0
1050	2043	8.2	2174	8.7	2295	9.2	2408	9.7	—	—
1125	2071	8.3	2203	8.8	2325	9.3	2439	9.8	—	—
1200	2098	8.4	2231	9.0	2354	9.5	2469	9.9	—	—
1275	2124	8.5	2258	9.1	2382	9.6	—	—	—	—
1350	2150	8.6	2285	9.2	2410	9.7	—	—	—	—
1425	2176	8.7	2311	9.3	2436	9.8	—	—	—	—
1500	2202	8.8	2337	9.4	2462	9.9	—	—	—	—

High Static 1017-2490 RPM

# Fan data (cont)

## RAV048 SINGLE PHASE — 4 TON HORIZONTAL SUPPLY (RPM - BHP)

CFM	AVAILABLE EXTERNAL STATIC PRESSURE (in. wg)									
	0.2		0.4		0.6		0.8		1.0	
	RPM	BHP	RPM	BHP	RPM	BHP	RPM	BHP	RPM	BHP
1200	1092	0.14	1306	0.24	1497	0.35	1667	0.49	1819	0.64
1300	1148	0.16	1348	0.26	1533	0.38	1700	0.52	1851	0.67
1400	1207	0.18	1394	0.28	1571	0.41	1734	0.55	1882	0.70
1500	1267	0.21	1442	0.31	1612	0.44	1770	0.58	1916	0.73
1600	1329	0.24	1493	0.35	1655	0.47	1808	0.61	1951	0.77
1700	1393	0.28	1546	0.38	1700	0.51	1848	0.65	1988	0.81
1800	1458	0.32	1602	0.42	1748	0.55	1890	0.70	2026	0.86
1900	1523	0.36	1659	0.47	1797	0.60	1934	0.75	2066	0.91
2000	1590	0.41	1719	0.52	1849	0.65	1980	0.80	2108	0.96

CFM	AVAILABLE EXTERNAL STATIC PRESSURE (in. wg)									
	1.2		1.4		1.6		1.8		2.0	
	RPM	BHP	RPM	BHP	RPM	BHP	RPM	BHP	RPM	BHP
1200	1958	0.79	2089	0.96	2211	1.14	2327	1.33	2438	1.53
1300	1988	0.83	2117	1.00	2238	1.18	2352	1.37	—	—
1400	2020	0.86	2146	1.03	2266	1.22	2379	1.41	—	—
1500	2051	0.90	2177	1.08	2296	1.26	2408	1.46	—	—
1600	2084	0.94	2209	1.12	2327	1.31	2438	1.51	—	—
1700	2119	0.99	2242	1.17	2358	1.36	—	—	—	—
1800	2154	1.03	2276	1.22	2391	1.41	—	—	—	—
1900	2191	1.08	2311	1.27	2424	1.47	—	—	—	—
2000	2230	1.14	2347	1.33	2459	1.53	—	—	—	—

Standard Static 1092-1900 RPM, 0.72 Max BHP

Medium Static 1092-2170 RPM, 1.06 Max BHP

High Static 1092-2460 RPM, 1.53 Max BHP

## RAV048 SINGLE PHASE – STANDARD STATIC — 4 TON HORIZONTAL SUPPLY (RPM - VDC)

CFM	AVAILABLE EXTERNAL STATIC PRESSURE (in. wg)									
	0.2		0.4		0.6		0.8		1.0	
	RPM	Vdc	RPM	Vdc	RPM	Vdc	RPM	Vdc	RPM	Vdc
1200	1092	5.7	1306	6.9	1497	7.9	1667	8.8	1819	9.6
1300	1148	6.0	1348	7.1	1533	8.1	1700	8.9	1851	9.7
1400	1207	6.4	1394	7.3	1571	8.3	1734	9.1	1882	9.9
1500	1267	6.7	1442	7.6	1612	8.5	1770	9.3	—	—
1600	1329	7.0	1493	7.9	1655	8.7	1808	9.5	—	—
1700	1393	7.3	1546	8.1	1700	8.9	1848	9.7	—	—
1800	1458	7.7	1602	8.4	1748	9.2	1890	9.9	—	—
1900	1523	8.0	1659	8.7	1797	9.5	—	—	—	—
2000	1590	8.4	1719	9.0	1849	9.7	—	—	—	—

CFM	AVAILABLE EXTERNAL STATIC PRESSURE (in. wg)									
	1.2		1.4		1.6		1.8		2.0	
	RPM	Vdc	RPM	Vdc	RPM	Vdc	RPM	Vdc	RPM	Vdc
1200	—	—	—	—	—	—	—	—	—	—
1300	—	—	—	—	—	—	—	—	—	—
1400	—	—	—	—	—	—	—	—	—	—
1500	—	—	—	—	—	—	—	—	—	—
1600	—	—	—	—	—	—	—	—	—	—
1700	—	—	—	—	—	—	—	—	—	—
1800	—	—	—	—	—	—	—	—	—	—
1900	—	—	—	—	—	—	—	—	—	—
2000	—	—	—	—	—	—	—	—	—	—

Standard Static 1092-1900 RPM

**RAV048 SINGLE PHASE – MEDIUM STATIC — 4 TON HORIZONTAL SUPPLY (RPM - VDC)**

CFM	AVAILABLE EXTERNAL STATIC PRESSURE (in. wg)									
	0.2		0.4		0.6		0.8		1.0	
	RPM	Vdc	RPM	Vdc	RPM	Vdc	RPM	Vdc	RPM	Vdc
1200	1092	5.0	1306	6.0	1497	6.9	1667	7.7	1819	8.4
1300	1148	5.3	1348	6.2	1533	7.1	1700	7.8	1851	8.5
1400	1207	5.6	1394	6.4	1571	7.2	1734	8.0	1882	8.7
1500	1267	5.8	1442	6.6	1612	7.4	1770	8.2	1916	8.8
1600	1329	6.1	1493	6.9	1655	7.6	1808	8.3	1951	9.0
1700	1393	6.4	1546	7.1	1700	7.8	1848	8.5	1988	9.2
1800	1458	6.7	1602	7.4	1748	8.1	1890	8.7	2026	9.3
1900	1523	7.0	1659	7.6	1797	8.3	1934	8.9	2066	9.5
2000	1590	7.3	1719	7.9	1849	8.5	1980	9.1	2108	9.7

CFM	AVAILABLE EXTERNAL STATIC PRESSURE (in. wg)									
	1.2		1.4		1.6		1.8		2.0	
	RPM	Vdc	RPM	Vdc	RPM	Vdc	RPM	Vdc	RPM	Vdc
1200	1959	9.0	2089	9.6	—	—	—	—	—	—
1300	1988	9.2	2117	9.8	—	—	—	—	—	—
1400	2020	9.3	2146	9.9	—	—	—	—	—	—
1500	2051	9.5	—	—	—	—	—	—	—	—
1600	2084	9.6	—	—	—	—	—	—	—	—
1700	2119	9.8	—	—	—	—	—	—	—	—
1800	2154	9.9	—	—	—	—	—	—	—	—
1900	—	—	—	—	—	—	—	—	—	—
2000	—	—	—	—	—	—	—	—	—	—

Medium Static 1092-2170 RPM

**RAV048 SINGLE PHASE – HIGH STATIC — 4 TON HORIZONTAL SUPPLY (RPM - VDC)**

CFM	AVAILABLE EXTERNAL STATIC PRESSURE (in. wg)									
	0.2		0.4		0.6		0.8		1.0	
	RPM	Vdc	RPM	Vdc	RPM	Vdc	RPM	Vdc	RPM	Vdc
1200	1092	4.4	1306	5.3	1497	6.1	1667	6.8	1819	7.4
1300	1148	4.7	1348	5.5	1533	6.2	1700	6.9	1851	7.5
1400	1207	4.9	1394	5.7	1571	6.4	1734	7.0	1882	7.7
1500	1267	5.2	1442	5.9	1612	6.6	1770	7.2	1916	7.8
1600	1329	5.4	1493	6.1	1655	6.7	1808	7.3	1951	7.9
1700	1393	5.7	1546	6.3	1700	6.9	1848	7.5	1988	8.1
1800	1458	5.9	1602	6.5	1748	7.1	1890	7.7	2026	8.2
1900	1523	6.2	1659	6.7	1797	7.3	1934	7.9	2066	8.4
2000	1590	6.5	1719	7.0	1849	7.5	1980	8.0	2108	8.6

CFM	AVAILABLE EXTERNAL STATIC PRESSURE (in. wg)									
	1.2		1.4		1.6		1.8		2.0	
	RPM	Vdc	RPM	Vdc	RPM	Vdc	RPM	Vdc	RPM	Vdc
1200	1959	8.0	2089	8.5	2211	9.0	2327	9.5	2438	9.9
1300	1988	8.1	2117	8.6	2238	9.1	2352	9.6	—	—
1400	2020	8.2	2146	8.7	2266	9.2	2379	9.7	—	—
1500	2051	8.3	2177	8.8	2296	9.3	2408	9.8	—	—
1600	2084	8.5	2209	9.0	2327	9.5	2438	9.9	—	—
1700	2119	8.6	2242	9.1	2358	9.6	—	—	—	—
1800	2154	8.8	2276	9.3	2391	9.7	—	—	—	—
1900	2191	8.9	2311	9.4	2424	9.9	—	—	—	—
2000	2230	9.1	2347	9.5	2459	10.0	—	—	—	—

High Static 1092-2460 RPM

# Fan data (cont)

## RAV048 THREE PHASE — 4 TON HORIZONTAL SUPPLY (RPM - BHP)

CFM	AVAILABLE EXTERNAL STATIC PRESSURE (in. wg)									
	0.2		0.4		0.6		0.8		1.0	
	RPM	BHP	RPM	BHP	RPM	BHP	RPM	BHP	RPM	BHP
1200	1093	0.14	1306	0.24	1497	0.35	1667	0.49	1819	0.64
1300	1148	0.16	1348	0.26	1533	0.38	1700	0.52	1850	0.67
1400	1206	0.18	1393	0.28	1571	0.41	1734	0.55	1883	0.70
1500	1266	0.21	1442	0.31	1612	0.44	1770	0.58	1916	0.73
1600	1329	0.24	1493	0.35	1655	0.47	1808	0.61	1951	0.77
1700	1393	0.28	1546	0.38	1700	0.51	1848	0.65	1988	0.81
1800	1458	0.32	1602	0.42	1747	0.55	1890	0.70	2026	0.86
1900	1523	0.36	1659	0.47	1797	0.60	1934	0.75	2066	0.91
2000	1590	0.41	1718	0.52	1849	0.65	1980	0.80	2108	0.96

CFM	AVAILABLE EXTERNAL STATIC PRESSURE (in. wg)									
	1.2		1.4		1.6		1.8		2.0	
	RPM	BHP	RPM	BHP	RPM	BHP	RPM	BHP	RPM	BHP
1200	1959	0.79	2089	0.96	2211	1.14	2327	1.33	2438	1.53
1300	1988	0.83	2117	1.00	2238	1.18	2352	1.37	2462	1.57
1400	2019	0.86	2146	1.03	2266	1.22	2379	1.41	2487	1.61
1500	2052	0.90	2177	1.08	2296	1.26	2408	1.46	2515	1.66
1600	2084	0.94	2209	1.12	2327	1.31	2438	1.51	2544	1.71
1700	2119	0.99	2242	1.17	2358	1.36	2469	1.56	2574	1.77
1800	2154	1.03	2276	1.22	2391	1.41	2500	1.61	2605	1.83
1900	2191	1.08	2311	1.27	2424	1.47	2533	1.68	2636	1.89
2000	2230	1.14	2347	1.33	2459	1.53	2566	1.74	—	—

Standard Static 1093-1900 RPM, 0.72 Max BHP

Medium Static 1093-2170 RPM, 1.06 Max BHP

High Static 1093-2660 RPM, 1.96 Max BHP

## RAV048 THREE PHASE – STANDARD STATIC — 4 TON HORIZONTAL SUPPLY (RPM - VDC)

CFM	AVAILABLE EXTERNAL STATIC PRESSURE (in. wg)									
	0.2		0.4		0.6		0.8		1.0	
	RPM	Vdc	RPM	Vdc	RPM	Vdc	RPM	Vdc	RPM	Vdc
1200	1093	5.8	1306	6.9	1497	7.9	1667	8.8	1819	9.6
1300	1148	6.0	1348	7.1	1533	8.1	1700	8.9	1850	9.7
1400	1206	6.3	1393	7.3	1571	8.3	1734	9.1	1883	9.9
1500	1266	6.7	1442	7.6	1612	8.5	1770	9.3	—	—
1600	1329	7.0	1493	7.9	1655	8.7	1808	9.5	—	—
1700	1393	7.3	1546	8.1	1700	8.9	1848	9.7	—	—
1800	1458	7.7	1602	8.4	1747	9.2	1890	9.9	—	—
1900	1523	8.0	1659	8.7	1797	9.5	—	—	—	—
2000	1590	8.4	1718	9.0	1849	9.7	—	—	—	—

CFM	AVAILABLE EXTERNAL STATIC PRESSURE (in. wg)									
	1.2		1.4		1.6		1.8		2.0	
	RPM	Vdc	RPM	Vdc	RPM	Vdc	RPM	Vdc	RPM	Vdc
1200	—	—	—	—	—	—	—	—	—	—
1300	—	—	—	—	—	—	—	—	—	—
1400	—	—	—	—	—	—	—	—	—	—
1500	—	—	—	—	—	—	—	—	—	—
1600	—	—	—	—	—	—	—	—	—	—
1700	—	—	—	—	—	—	—	—	—	—
1800	—	—	—	—	—	—	—	—	—	—
1900	—	—	—	—	—	—	—	—	—	—
2000	—	—	—	—	—	—	—	—	—	—

Standard Static 1093-1900 RPM

**RAV048 THREE PHASE – MEDIUM STATIC — 4 TON HORIZONTAL SUPPLY (RPM - VDC)**

CFM	AVAILABLE EXTERNAL STATIC PRESSURE (in. wg)									
	0.2		0.4		0.6		0.8		1.0	
	RPM	Vdc	RPM	Vdc	RPM	Vdc	RPM	Vdc	RPM	Vdc
1200	1093	5.0	1306	6.0	1497	6.9	1667	7.7	1819	8.4
1300	1148	5.3	1348	6.2	1533	7.1	1700	7.8	1850	8.5
1400	1206	5.6	1393	6.4	1571	7.2	1734	8.0	1883	8.7
1500	1266	5.8	1442	6.6	1612	7.4	1770	8.2	1916	8.8
1600	1329	6.1	1493	6.9	1655	7.6	1808	8.3	1951	9.0
1700	1393	6.4	1546	7.1	1700	7.8	1848	8.5	1988	9.2
1800	1458	6.7	1602	7.4	1747	8.1	1890	8.7	2026	9.3
1900	1523	7.0	1659	7.6	1797	8.3	1934	8.9	2066	9.5
2000	1590	7.3	1718	7.9	1849	8.5	1980	9.1	2108	9.7

CFM	AVAILABLE EXTERNAL STATIC PRESSURE (in. wg)									
	1.2		1.4		1.6		1.8		2.0	
	RPM	Vdc	RPM	Vdc	RPM	Vdc	RPM	Vdc	RPM	Vdc
1200	1959	9.0	2089	9.6	—	—	—	—	—	—
1300	1988	9.2	2117	9.8	—	—	—	—	—	—
1400	2019	9.3	2146	9.9	—	—	—	—	—	—
1500	2052	9.5	—	—	—	—	—	—	—	—
1600	2084	9.6	—	—	—	—	—	—	—	—
1700	2119	9.8	—	—	—	—	—	—	—	—
1800	2154	9.9	—	—	—	—	—	—	—	—
1900	—	—	—	—	—	—	—	—	—	—
2000	—	—	—	—	—	—	—	—	—	—

Medium Static 1093-2170 RPM

**RAV048 THREE PHASE – HIGH STATIC — 4 TON HORIZONTAL SUPPLY (RPM - VDC)**

CFM	AVAILABLE EXTERNAL STATIC PRESSURE (in. wg)									
	0.2		0.4		0.6		0.8		1.0	
	RPM	Vdc	RPM	Vdc	RPM	Vdc	RPM	Vdc	RPM	Vdc
1200	1093	4.1	1306	4.9	1497	5.6	1667	6.3	1819	6.8
1300	1148	4.3	1348	5.1	1533	5.8	1700	6.4	1850	7.0
1400	1206	4.5	1393	5.2	1571	5.9	1734	6.5	1883	7.1
1500	1266	4.8	1442	5.4	1612	6.1	1770	6.7	1916	7.2
1600	1329	5.0	1493	5.6	1655	6.2	1808	6.8	1951	7.3
1700	1393	5.2	1546	5.8	1700	6.4	1848	6.9	1988	7.5
1800	1458	5.5	1602	6.0	1747	6.6	1890	7.1	2026	7.6
1900	1523	5.7	1659	6.2	1797	6.8	1934	7.3	2066	7.8
2000	1590	6.0	1718	6.5	1849	7.0	1980	7.4	2108	7.9

CFM	AVAILABLE EXTERNAL STATIC PRESSURE (in. wg)									
	1.2		1.4		1.6		1.8		2.0	
	RPM	Vdc	RPM	Vdc	RPM	Vdc	RPM	Vdc	RPM	Vdc
1200	1959	7.4	2089	7.9	2211	8.3	2327	8.7	2438	9.2
1300	1988	7.5	2117	8.0	2238	8.4	2352	8.8	2462	9.3
1400	2019	7.6	2146	8.1	2266	8.5	2379	8.9	2487	9.3
1500	2052	7.7	2177	8.2	2296	8.6	2408	9.1	2515	9.5
1600	2084	7.8	2209	8.3	2327	8.7	2438	9.2	2544	9.6
1700	2119	8.0	2242	8.4	2358	8.9	2469	9.3	2574	9.7
1800	2154	8.1	2276	8.6	2391	9.0	2500	9.4	2605	9.8
1900	2191	8.2	2311	8.7	2424	9.1	2533	9.5	2636	9.9
2000	2230	8.4	2347	8.8	2459	9.2	2566	9.6	—	—

High Static 1093-2660 RPM

# Fan data (cont)

## RAV060 SINGLE PHASE — 5 TON HORIZONTAL SUPPLY (RPM - BHP)

CFM	AVAILABLE EXTERNAL STATIC PRESSURE (in. wg)									
	0.2		0.4		0.6		0.8		1.0	
	RPM	BHP	RPM	BHP	RPM	BHP	RPM	BHP	RPM	BHP
1500	1267	0.21	1442	0.31	1612	0.44	1770	0.58	1916	0.73
1625	1345	0.25	1506	0.35	1666	0.48	1818	0.62	1960	0.78
1750	1425	0.30	1574	0.40	1723	0.53	1869	0.68	2006	0.84
1875	1507	0.35	1644	0.46	1785	0.59	1923	0.73	2056	0.90
2000	1590	0.41	1718	0.52	1849	0.65	1980	0.80	2108	0.96
2125	1674	0.48	1794	0.59	1917	0.72	2041	0.87	2163	1.04
2250	1759	0.56	1872	0.67	1987	0.80	2104	0.95	2221	1.12
2375	1845	0.64	1951	0.76	2060	0.89	2171	1.05	2281	1.21
2500	1932	0.74	2032	0.86	2135	0.99	2239	1.15	2345	1.32

CFM	AVAILABLE EXTERNAL STATIC PRESSURE (in. wg)									
	1.2		1.4		1.6		1.8		2.0	
	RPM	BHP	RPM	BHP	RPM	BHP	RPM	BHP	RPM	BHP
1500	2051	0.90	2177	1.08	2296	1.26	—	—	—	—
1625	2093	0.95	2217	1.13	2334	1.32	—	—	—	—
1750	2136	1.01	2259	1.19	2374	1.38	—	—	—	—
1875	2182	1.07	2302	1.26	—	—	—	—	—	—
2000	2230	1.14	2347	1.33	—	—	—	—	—	—
2125	2281	1.22	—	—	—	—	—	—	—	—
2250	2334	1.30	—	—	—	—	—	—	—	—
2375	2390	1.40	—	—	—	—	—	—	—	—
2500	—	—	—	—	—	—	—	—	—	—

Standard Static 1267-2150 RPM, 1.06 Max BHP

Medium Static 1267-2390 RPM, 1.44 Max BHP

## RAV060 SINGLE PHASE – STANDARD STATIC — 5 TON HORIZONTAL SUPPLY (RPM - VDC)

CFM	AVAILABLE EXTERNAL STATIC PRESSURE (in. wg)									
	0.2		0.4		0.6		0.8		1.0	
	RPM	Vdc	RPM	Vdc	RPM	Vdc	RPM	Vdc	RPM	Vdc
1500	1267	5.9	1442	6.7	1612	7.5	1770	8.2	1916	8.9
1625	1345	6.3	1506	7.0	1666	7.7	1818	8.5	1960	9.1
1750	1425	6.6	1574	7.3	1723	8.0	1869	8.7	2006	9.3
1875	1507	7.0	1644	7.6	1785	8.3	1923	8.9	2056	9.6
2000	1590	7.4	1719	8.0	1849	8.6	1980	9.2	2108	9.8
2125	1674	7.8	1794	8.3	1917	8.9	2041	9.5	—	—
2250	1760	8.2	1872	8.7	1987	9.2	2104	9.8	—	—
2375	1845	8.6	1951	9.1	2060	9.6	—	—	—	—
2500	1932	9.0	2032	9.5	2135	9.9	—	—	—	—

CFM	AVAILABLE EXTERNAL STATIC PRESSURE (in. wg)									
	1.2		1.4		1.6		1.8		2.0	
	RPM	Vdc	RPM	Vdc	RPM	Vdc	RPM	Vdc	RPM	Vdc
1500	2051	9.5	—	—	—	—	—	—	—	—
1625	2093	9.7	—	—	—	—	—	—	—	—
1750	2136	9.9	—	—	—	—	—	—	—	—
1875	—	—	—	—	—	—	—	—	—	—
2000	—	—	—	—	—	—	—	—	—	—
2125	—	—	—	—	—	—	—	—	—	—
2250	—	—	—	—	—	—	—	—	—	—
2375	—	—	—	—	—	—	—	—	—	—
2500	—	—	—	—	—	—	—	—	—	—

Standard Static 1267-2150 RPM

**RAV060 SINGLE PHASE – MEDIUM STATIC — 5 TON HORIZONTAL SUPPLY (RPM - VDC)**

CFM	AVAILABLE EXTERNAL STATIC PRESSURE (in. wg)									
	0.2		0.4		0.6		0.8		1.0	
	RPM	Vdc	RPM	Vdc	RPM	Vdc	RPM	Vdc	RPM	Vdc
1500	1267	5.3	1442	6.0	1612	6.7	1770	7.4	1916	8.0
1625	1345	5.6	1506	6.3	1666	7.0	1818	7.6	1960	8.2
1750	1425	6.0	1574	6.6	1723	7.2	1869	7.8	2006	8.4
1875	1507	6.3	1644	6.9	1785	7.5	1923	8.0	2056	8.6
2000	1590	6.7	1719	7.2	1849	7.7	1980	8.3	2108	8.8
2125	1674	7.0	1794	7.5	1917	8.0	2041	8.5	2163	9.1
2250	1760	7.4	1872	7.8	1987	8.3	2104	8.8	2221	9.3
2375	1845	7.7	1951	8.2	2060	8.6	2171	9.1	2281	9.5
2500	1932	8.1	2032	8.5	2135	8.9	2239	9.4	2345	9.8

CFM	AVAILABLE EXTERNAL STATIC PRESSURE (in. wg)									
	1.2		1.4		1.6		1.8		2.0	
	RPM	Vdc	RPM	Vdc	RPM	Vdc	RPM	Vdc	RPM	Vdc
1500	2051	8.6	2177	9.1	2296	9.6	—	—	—	—
1625	2093	8.8	2217	9.3	2334	9.8	—	—	—	—
1750	2136	8.9	2259	9.5	2374	9.9	—	—	—	—
1875	2182	9.1	2302	9.6	—	—	—	—	—	—
2000	2230	9.3	2347	9.8	—	—	—	—	—	—
2125	2281	9.5	—	—	—	—	—	—	—	—
2250	2334	9.8	—	—	—	—	—	—	—	—
2375	—	—	—	—	—	—	—	—	—	—
2500	—	—	—	—	—	—	—	—	—	—

Medium Static 1267-2390 RPM

# Fan data (cont)

## RAV060 THREE PHASE — 5 TON HORIZONTAL SUPPLY (RPM - BHP)

CFM	AVAILABLE EXTERNAL STATIC PRESSURE (in. wg)									
	0.2		0.4		0.6		0.8		1.0	
	RPM	BHP	RPM	BHP	RPM	BHP	RPM	BHP	RPM	BHP
1500	1267	0.21	1442	0.31	1612	0.44	1770	0.58	1916	0.73
1625	1345	0.25	1506	0.35	1666	0.48	1818	0.62	1960	0.78
1750	1425	0.30	1574	0.40	1723	0.53	1869	0.68	2006	0.84
1875	1507	0.35	1644	0.46	1785	0.59	1923	0.73	2056	0.90
2000	1590	0.41	1718	0.52	1849	0.65	1980	0.80	2108	0.96
2125	1674	0.48	1794	0.59	1917	0.72	2041	0.87	2163	1.04
2250	1759	0.56	1872	0.67	1987	0.80	2104	0.95	2221	1.12
2375	1845	0.64	1951	0.76	2060	0.89	2171	1.05	2281	1.21
2500	1932	0.74	2032	0.86	2135	0.99	2239	1.15	2345	1.32

CFM	AVAILABLE EXTERNAL STATIC PRESSURE (in. wg)									
	1.2		1.4		1.6		1.8		2.0	
	RPM	BHP	RPM	BHP	RPM	BHP	RPM	BHP	RPM	BHP
1500	2051	0.90	2177	1.08	2296	1.26	2408	1.46	2515	1.66
1625	2093	0.95	2217	1.13	2334	1.32	2445	1.52	2551	1.72
1750	2136	1.01	2259	1.19	2374	1.38	2484	1.59	2589	1.80
1875	2182	1.07	2302	1.26	2416	1.45	2524	1.66	2628	1.87
2000	2230	1.14	2347	1.33	2459	1.53	2566	1.74	2669	1.96
2125	2281	1.22	2395	1.41	2505	1.61	2610	1.83	2711	2.05
2250	2334	1.30	2445	1.50	2552	1.70	2655	1.92	2754	2.14
2375	2391	1.40	2497	1.59	2601	1.80	2702	2.02	2800	2.25
2500	2449	1.50	2552	1.70	2653	1.91	2751	2.13	—	—

Standard Static 1267-2150 RPM, 1.06 Max BHP

Medium Static 1267-2390 RPM, 1.44 Max BHP

High Static 1267-2836 RPM, 2.43 Max BHP

## RAV060 THREE PHASE – STANDARD STATIC — 5 TON HORIZONTAL SUPPLY (RPM - VDC)

CFM	AVAILABLE EXTERNAL STATIC PRESSURE (in. wg)									
	0.2		0.4		0.6		0.8		1.0	
	RPM	Vdc	RPM	Vdc	RPM	Vdc	RPM	Vdc	RPM	Vdc
1500	1267	5.9	1442	6.7	1612	7.5	1770	8.2	1916	8.9
1625	1345	6.3	1506	7.0	1666	7.7	1818	8.5	1960	9.1
1750	1425	6.6	1574	7.3	1723	8.0	1869	8.7	2006	9.3
1875	1507	7.0	1644	7.6	1785	8.3	1923	8.9	2056	9.6
2000	1590	7.4	1719	8.0	1849	8.6	1980	9.2	2108	9.8
2125	1674	7.8	1794	8.3	1917	8.9	2041	9.5	—	—
2250	1760	8.2	1872	8.7	1987	9.2	2104	9.8	—	—
2375	1845	8.6	1951	9.1	2060	9.6	—	—	—	—
2500	1932	9.0	2032	9.5	2135	9.9	—	—	—	—

CFM	AVAILABLE EXTERNAL STATIC PRESSURE (in. wg)									
	1.2		1.4		1.6		1.8		2.0	
	RPM	Vdc	RPM	Vdc	RPM	Vdc	RPM	Vdc	RPM	Vdc
1500	2051	9.5	—	—	—	—	—	—	—	—
1625	2093	9.7	—	—	—	—	—	—	—	—
1750	2136	9.9	—	—	—	—	—	—	—	—
1875	—	—	—	—	—	—	—	—	—	—
2000	—	—	—	—	—	—	—	—	—	—
2125	—	—	—	—	—	—	—	—	—	—
2250	—	—	—	—	—	—	—	—	—	—
2375	—	—	—	—	—	—	—	—	—	—
2500	—	—	—	—	—	—	—	—	—	—

Standard Static 1267-2150 RPM

**RAV060 THREE PHASE – MEDIUM STATIC — 5 TON HORIZONTAL SUPPLY (RPM - VDC)**

CFM	AVAILABLE EXTERNAL STATIC PRESSURE (in. wg)									
	0.2		0.4		0.6		0.8		1.0	
	RPM	Vdc	RPM	Vdc	RPM	Vdc	RPM	Vdc	RPM	Vdc
1500	1267	5.3	1442	6.0	1612	6.7	1770	7.4	1916	8.0
1625	1345	5.6	1506	6.3	1666	7.0	1818	7.6	1960	8.2
1750	1425	6.0	1574	6.6	1723	7.2	1869	7.8	2006	8.4
1875	1507	6.3	1644	6.9	1785	7.5	1923	8.0	2056	8.6
2000	1590	6.7	1719	7.2	1849	7.7	1980	8.3	2108	8.8
2125	1674	7.0	1794	7.5	1917	8.0	2041	8.5	2163	9.1
2250	1760	7.4	1872	7.8	1987	8.3	2104	8.8	2221	9.3
2375	1845	7.7	1951	8.2	2060	8.6	2171	9.1	2281	9.5
2500	1932	8.1	2032	8.5	2135	8.9	2239	9.4	2345	9.8

CFM	AVAILABLE EXTERNAL STATIC PRESSURE (in. wg)									
	1.2		1.4		1.6		1.8		2.0	
	RPM	Vdc	RPM	Vdc	RPM	Vdc	RPM	Vdc	RPM	Vdc
1500	2051	8.6	2177	9.1	2296	9.6	—	—	—	—
1625	2093	8.8	2217	9.3	2334	9.8	—	—	—	—
1750	2136	8.9	2259	9.5	2374	9.9	—	—	—	—
1875	2182	9.1	2302	9.6	—	—	—	—	—	—
2000	2230	9.3	2347	9.8	—	—	—	—	—	—
2125	2281	9.5	—	—	—	—	—	—	—	—
2250	2334	9.8	—	—	—	—	—	—	—	—
2375	—	—	—	—	—	—	—	—	—	—
2500	—	—	—	—	—	—	—	—	—	—

Medium Static 1267-2390 RPM

**RAV060 THREE PHASE – HIGH STATIC — 5 TON HORIZONTAL SUPPLY (RPM - VDC)**

CFM	AVAILABLE EXTERNAL STATIC PRESSURE (in. wg)									
	0.2		0.4		0.6		0.8		1.0	
	RPM	Vdc	RPM	Vdc	RPM	Vdc	RPM	Vdc	RPM	Vdc
1500	1267	4.5	1442	5.1	1612	5.7	1770	6.2	1916	6.8
1625	1345	4.7	1506	5.3	1666	5.9	1818	6.4	1960	6.9
1750	1425	5.0	1574	5.6	1723	6.1	1869	6.6	2006	7.1
1875	1507	5.3	1644	5.8	1785	6.3	1923	6.8	2056	7.2
2000	1590	5.6	1719	6.1	1849	6.5	1980	7.0	2108	7.4
2125	1674	5.9	1794	6.3	1917	6.8	2041	7.2	2163	7.6
2250	1760	6.2	1872	6.6	1987	7.0	2104	7.4	2221	7.8
2375	1845	6.5	1951	6.9	2060	7.3	2171	7.7	2281	8.0
2500	1932	6.8	2032	7.2	2135	7.5	2239	7.9	2345	8.3

CFM	AVAILABLE EXTERNAL STATIC PRESSURE (in. wg)									
	1.2		1.4		1.6		1.8		2.0	
	RPM	Vdc	RPM	Vdc	RPM	Vdc	RPM	Vdc	RPM	Vdc
1500	2051	7.2	2177	7.7	2296	8.1	2408	8.5	2515	8.9
1625	2093	7.4	2217	7.8	2334	8.2	2445	8.6	2551	9.0
1750	2136	7.5	2259	8.0	2374	8.4	2484	8.8	2589	9.1
1875	2182	7.7	2302	8.1	2416	8.5	2524	8.9	2628	9.3
2000	2230	7.9	2347	8.3	2459	8.7	2566	9.0	2669	9.4
2125	2281	8.0	2395	8.4	2505	8.8	2610	9.2	2711	9.6
2250	2334	8.2	2445	8.6	2552	9.0	2655	9.4	2755	9.7
2375	2391	8.4	2498	8.8	2602	9.2	2702	9.5	2800	9.9
2500	2449	8.6	2552	9.0	2653	9.4	2752	9.7	—	—

High Static 1267-2836 RPM

# Fan data (cont)

## RAV072 THREE PHASE — 6 TON HORIZONTAL SUPPLY (RPM - BHP)

CFM	AVAILABLE EXTERNAL STATIC PRESSURE (in. wg)									
	0.2		0.4		0.6		0.8		1.0	
	RPM	BHP	RPM	BHP	RPM	BHP	RPM	BHP	RPM	BHP
1800	1379	0.27	1512	0.35	1650	0.46	1786	0.58	1918	0.72
1950	1473	0.32	1594	0.41	1721	0.52	1848	0.64	1973	0.78
2100	1569	0.39	1680	0.48	1796	0.59	1915	0.71	2032	0.85
2250	1666	0.47	1769	0.56	1876	0.67	1986	0.79	2096	0.93
2400	1764	0.55	1860	0.65	1959	0.76	2061	0.88	2165	1.02
2550	1863	0.65	1952	0.75	2045	0.86	2140	0.99	2237	1.13
2700	1963	0.76	2047	0.86	2133	0.97	2222	1.10	2313	1.24
2850	2063	0.88	2142	0.99	2223	1.10	2307	1.23	2393	1.37
3000	2163	1.01	2238	1.12	2315	1.24	2394	1.37	2474	1.52

CFM	AVAILABLE EXTERNAL STATIC PRESSURE (in. wg)									
	1.2		1.4		1.6		1.8		2.0	
	RPM	BHP	RPM	BHP	RPM	BHP	RPM	BHP	RPM	BHP
1800	2044	0.87	2163	1.03	2276	1.20	2383	1.38	2486	1.57
1950	2094	0.93	2210	1.10	2320	1.27	2426	1.45	2527	1.64
2100	2148	1.00	2260	1.17	2367	1.34	2471	1.53	2570	1.72
2250	2206	1.08	2313	1.25	2417	1.43	2518	1.61	2616	1.81
2400	2268	1.18	2371	1.34	2471	1.52	2569	1.71	2664	1.90
2550	2335	1.28	2432	1.45	2528	1.62	2622	1.81	2715	2.01
2700	2405	1.40	2497	1.56	2589	1.74	2680	1.93	2769	2.13
2850	2479	1.53	2566	1.69	2654	1.87	2740	2.06	2826	2.26
3000	2556	1.67	2639	1.84	2722	2.02	2804	2.21	—	—

Standard Static 1379-2300 RPM, 1.31 Max BHP

Medium Static 1379-2530 RPM, 1.76 Max BHP

High Static 1379-2836 RPM, 2.43 Max BHP

## RAV072 THREE PHASE – STANDARD STATIC — 6 TON HORIZONTAL SUPPLY (RPM - VDC)

CFM	AVAILABLE EXTERNAL STATIC PRESSURE (in. wg)									
	0.2		0.4		0.6		0.8		1.0	
	RPM	Vdc	RPM	Vdc	RPM	Vdc	RPM	Vdc	RPM	Vdc
1800	1379	6.0	1512	6.6	1650	7.2	1786	7.8	1918	8.3
1950	1473	6.4	1594	6.9	1721	7.5	1848	8.0	1973	8.6
2100	1569	6.8	1680	7.3	1796	7.8	1915	8.3	2032	8.8
2250	1666	7.2	1769	7.7	1876	8.2	1986	8.6	2096	9.1
2400	1764	7.7	1860	8.1	1959	8.5	2061	9.0	2165	9.4
2550	1863	8.1	1952	8.5	2045	8.9	2140	9.3	2237	9.7
2700	1963	8.5	2047	8.9	2133	9.3	2222	9.7	—	—
2850	2063	9.0	2142	9.3	2223	9.7	—	—	—	—
3000	2163	9.4	2238	9.7	—	—	—	—	—	—

CFM	AVAILABLE EXTERNAL STATIC PRESSURE (in. wg)									
	1.2		1.4		1.6		1.8		2.0	
	RPM	Vdc	RPM	Vdc	RPM	Vdc	RPM	Vdc	RPM	Vdc
1800	2044	8.9	2163	9.4	2276	9.9	—	—	—	—
1950	2094	9.1	2210	9.6	—	—	—	—	—	—
2100	2148	9.3	2260	9.8	—	—	—	—	—	—
2250	2206	9.6	—	—	—	—	—	—	—	—
2400	2268	9.9	—	—	—	—	—	—	—	—
2550	—	—	—	—	—	—	—	—	—	—
2700	—	—	—	—	—	—	—	—	—	—
2850	—	—	—	—	—	—	—	—	—	—
3000	—	—	—	—	—	—	—	—	—	—

Standard Static 1379-2300 RPM

**RAV072 THREE PHASE – MEDIUM STATIC — 6 TON HORIZONTAL SUPPLY (RPM - VDC)**

CFM	AVAILABLE EXTERNAL STATIC PRESSURE (in. wg)									
	0.2		0.4		0.6		0.8		1.0	
	RPM	Vdc	RPM	Vdc	RPM	Vdc	RPM	Vdc	RPM	Vdc
1800	1379	5.5	1512	6.0	1650	6.5	1786	7.1	1918	7.6
1950	1473	5.8	1594	6.3	1721	6.8	1848	7.3	1973	7.8
2100	1569	6.2	1680	6.6	1796	7.1	1915	7.6	2032	8.0
2250	1666	6.6	1769	7.0	1876	7.4	1986	7.8	2096	8.3
2400	1764	7.0	1860	7.4	1959	7.7	2061	8.1	2165	8.6
2550	1863	7.4	1952	7.7	2045	8.1	2140	8.5	2237	8.8
2700	1963	7.8	2047	8.1	2133	8.4	2222	8.8	2313	9.1
2850	2063	8.2	2142	8.5	2223	8.8	2307	9.1	2393	9.5
3000	2163	8.5	2238	8.8	2315	9.2	2394	9.5	2474	9.8

CFM	AVAILABLE EXTERNAL STATIC PRESSURE (in. wg)									
	1.2		1.4		1.6		1.8		2.0	
	RPM	Vdc	RPM	Vdc	RPM	Vdc	RPM	Vdc	RPM	Vdc
1800	2044	8.1	2163	8.5	2276	9.0	2383	9.4	2486	9.8
1950	2094	8.3	2210	8.7	2320	9.2	2426	9.6	2527	10.0
2100	2148	8.5	2260	8.9	2367	9.4	2471	9.8	—	—
2250	2206	8.7	2313	9.1	2417	9.6	2518	10.0	—	—
2400	2268	9.0	2371	9.4	2471	9.8	—	—	—	—
2550	2335	9.2	2432	9.6	2528	10.0	—	—	—	—
2700	2405	9.5	2497	9.9	—	—	—	—	—	—
2850	2479	9.8	—	—	—	—	—	—	—	—
3000	—	—	—	—	—	—	—	—	—	—

Medium Static 1379-2530 RPM

**RAV072 THREE PHASE – HIGH STATIC — 6 TON HORIZONTAL SUPPLY (RPM - VDC)**

CFM	AVAILABLE EXTERNAL STATIC PRESSURE (in. wg)									
	0.2		0.4		0.6		0.8		1.0	
	RPM	Vdc	RPM	Vdc	RPM	Vdc	RPM	Vdc	RPM	Vdc
1800	1379	4.9	1512	5.3	1650	5.8	1786	6.3	1918	6.8
1950	1473	5.2	1594	5.6	1721	6.1	1848	6.5	1973	7.0
2100	1569	5.5	1680	5.9	1796	6.3	1915	6.8	2032	7.2
2250	1666	5.9	1769	6.2	1876	6.6	1986	7.0	2096	7.4
2400	1764	6.2	1860	6.6	1959	6.9	2061	7.3	2165	7.6
2550	1863	6.6	1952	6.9	2045	7.2	2140	7.5	2237	7.9
2700	1963	6.9	2047	7.2	2133	7.5	2222	7.8	2313	8.2
2850	2063	7.3	2142	7.6	2223	7.8	2307	8.1	2393	8.4
3000	2163	7.6	2238	7.9	2315	8.2	2394	8.4	2474	8.7

CFM	AVAILABLE EXTERNAL STATIC PRESSURE (in. wg)									
	1.2		1.4		1.6		1.8		2.0	
	RPM	Vdc	RPM	Vdc	RPM	Vdc	RPM	Vdc	RPM	Vdc
1800	2044	7.2	2163	7.6	2276	8.0	2383	8.4	2486	8.8
1950	2094	7.4	2210	7.8	2320	8.2	2426	8.6	2527	8.9
2100	2148	7.6	2260	8.0	2367	8.3	2471	8.7	2570	9.1
2250	2206	7.8	2313	8.2	2417	8.5	2518	8.9	2616	9.2
2400	2268	8.0	2371	8.4	2471	8.7	2569	9.1	2664	9.4
2550	2335	8.2	2432	8.6	2528	8.9	2622	9.2	2715	9.6
2700	2405	8.5	2497	8.8	2589	9.1	2680	9.4	2769	9.8
2850	2479	8.7	2566	9.0	2654	9.4	2740	9.7	2826	10.0
3000	2556	9.0	2639	9.3	2722	9.6	2804	9.9	—	—

High Static 1379-2836 RPM

# Electrical data

## Legend and Notes

Applicable for Electrical Data Tables on pages 97 to 117

### LEGEND

<b>BRKR</b>	— Circuit Breaker
<b>C.O.</b>	— Convenience Outlet
<b>FLA</b>	— Full Load Amps
<b>IFM</b>	— Indoor Fan Motor
<b>LRA</b>	— Locked Rotor Amps
<b>MCA</b>	— Minimum Circuit Amps
<b>P.E.</b>	— Power Exhaust
<b>PWRD C.O.</b>	— Powered Convenience Outlet
<b>RLA</b>	— Rated Load Amps
<b>UNPWR C.O.</b>	— Unpowered Convenience Outlet

### NOTES:

1. In compliance with NEC requirements for multi-motor and combination load equipment (refer to NEC Articles 430 and 440), the overcurrent protective device for the unit shall be fuse or HACR breaker. Canadian units may be fuse or circuit breaker.
2. For 208/230 v units, where one value is show it is the same for either 208 or 230 volts.
3. **Unbalanced 3-Phase Supply Voltage**  
Never operate a motor where a phase imbalance in supply voltage is greater than 2%. Use the following formula to determine the percentage of voltage imbalance.

% Voltage Imbalance:

$$= 100 \times \frac{\text{max voltage deviation from average voltage}}{\text{average voltage}}$$

Example: Supply voltage is 230-3-60



AB = 224 v  
BC = 231 v  
AC = 226 v

$$\text{Average Voltage} = \frac{(224 + 231 + 226)}{3} = \frac{681}{3} = 227$$

Determine maximum deviation from average voltage.

$$(AB) 227-224 = 3 \text{ v}$$

$$(BC) 231-227 = 4 \text{ v}$$

$$(AC) 227-226 = 1 \text{ v}$$

Maximum deviation is 4 v.

Determine percent of voltage imbalance.

$$\% \text{ Voltage Imbalance} = 100 \times \frac{4}{227} = 1.78\%$$

This amount of phase imbalance is satisfactory as it is below the maximum allowable 2%.

**IMPORTANT:** If the supply voltage phase imbalance is more than 2%, contact your local electric utility company immediately.

NOTE: Check all factory and field electrical connections for tightness.

**RGV/RAV036-072 COOLING ELECTRICAL DATA**

RGV/RAV UNIT	V-PH-HZ	UNIT VOLTAGE		COMPRESSOR		OFM (EA)		IFM			COMBUSTION FAN MOTOR	POWER EXHAUST	
		RANGE		RLA	LRA	WATTS	FLA	TYPE	EFFCY AT FULL LOAD	FLA	FLA	KIT QTY	FLA (EA KIT)
		MIN	MAX										
036	208-1-60	187	253	15.4	84	275	1.5	STD	83%	3.0	0.48	1	1.9
								MED	84%	4.5			
								HIGH	89%	6.1			
	230-1-60	187	253	15.4	84	275	1.5	STD	83%	3.0	0.48	1	1.9
								MED	84%	4.5			
								HIGH	89%	6.1			
	208-3-60	187	253	10.4	73	275	1.5	STD	83%	3.0	0.48	1	1.9
								MED	84%	4.5			
								HIGH	89%	6.1			
	230-3-60	187	253	10.4	73	275	1.5	STD	83%	3.0	0.48	1	1.9
								MED	84%	4.5			
								HIGH	89%	6.1			
	460-3-60	414	506	5.8	38	275	0.8	STD	85%	0.8	0.25	1	1.0
								MED	85%	1.2			
								HIGH	84%	1.5			
	575-3-60	518	633	3.8	37	275	0.6	STD	84%	0.8	0.24	1	1.9
								MED	84%	1.1			
								HIGH	85%	1.5			
048	208-1-60	187	253	19.6	130	275	1.5	STD	84%	4.5	0.48	1	1.9
								MED	88%	6.1			
								HIGH	84%	8.8			
	230-1-60	187	253	19.6	130	275	1.5	STD	84%	4.5	0.48	1	1.9
								MED	88%	6.1			
								HIGH	84%	8.8			
	208-3-60	187	253	13.7	83	275	1.5	STD	84%	4.5	0.48	1	1.9
								MED	88%	6.1			
								HIGH	85%	5.1			
	230-3-60	187	253	13.7	83	275	1.5	STD	84%	4.5	0.48	1	1.9
								MED	88%	6.1			
								HIGH	85%	5.1			
	460-3-60	414	506	6.2	41	275	0.8	STD	85%	1.2	0.25	1	1.0
								MED	86%	1.5			
								HIGH	88%	2.4			
	575-3-60	518	633	4.8	33	275	0.6	STD	84%	1.1	0.24	1	1.9
								MED	85%	1.5			
								HIGH	88%	2.2			
060	208-1-60	187	253	24.4	144	275	1.5	STD	85%	6.4	0.48	1	1.9
								MED	84%	8.6			
	230-1-60	187	253	24.4	144	275	1.5	STD	85%	6.4	0.48	1	1.9
								MED	84%	8.6			
	208-3-60	187	253	16.0	110	275	1.5	STD	85%	6.4	0.48	1	1.9
								MED	84%	8.6			
								HIGH	84%	6.4			
	230-3-60	187	253	16.0	110	275	1.5	STD	85%	6.4	0.48	1	1.9
								MED	84%	8.6			
								HIGH	84%	6.4			
	460-3-60	414	506	7.8	52	275	0.8	STD	86%	1.5	0.25	1	1.0
								MED	86%	1.9			
								HIGH	88%	2.9			
	575-3-60	518	633	5.7	39	275	0.6	STD	84%	1.5	0.24	1	1.9
								MED	85%	1.8			
								HIGH	87%	2.5			

# Electrical data (cont)

## RGV/RAV036-072 COOLING ELECTRICAL DATA (cont)

RGV/RAV UNIT	V-PH-HZ	UNIT VOLTAGE		COMPRESSOR		OFM (EA)		IFM			COMBUSTION FAN MOTOR	POWER EXHAUST	
		RANGE		RLA	LRA	WATTS	FLA	TYPE	EFFCY AT FULL LOAD	FLA	FLA	KIT QTY	FLA (EA KIT)
		MIN	MAX										
072	208-3-60	187	253	17.5	136	275	1.5	STD	84%	7.8	0.48	1	1.9
								MED	88%	4.5			
								HIGH	84%	6.4			
	230-3-60	187	253	17.5	136	275	1.5	STD	84%	7.8	0.48	1	1.9
								MED	88%	4.5			
								HIGH	84%	6.4			
	460-3-60	414	506	8.4	66	275	0.8	STD	85%	1.8	0.25	1	1.0
								MED	88%	2.2			
								HIGH	88%	2.9			
	575-3-60	518	633	6.3	55	275	0.6	STD	85%	1.7	0.24	1	1.9
								MED	88%	2.0			
								HIGH	87%	2.5			

**RGV/RAV036-072 MCA MOCP ELECTRICAL DATA**

RGV UNIT SIZE	NOM. V-PH-Hz	IFM TYPE	NO CONVENIENCE OUTLET OR UNPOWERED CONVENIENCE OUTLET							
			NO POWER EXHAUST				W/ POWER EXHAUST (POWERED FROM UNIT)			
			MCA	FUSE OR HACR BREAKER	DISCONNECT SIZE		MCA	FUSE OR HACR BREAKER	DISCONNECT SIZE	
FLA	LRA	FLA			LRA					
036	208/230-1-60	STD	24	30	23	92	26	30	25	94
		MED	26	30	25	94	28	40	27	96
		HIGH	27	40	26	97	29	40	29	99
	208/230-3-60	STD	18	25	17	81	20	25	19	83
		MED	19	25	19	83	21	30	21	85
		HIGH	21	30	21	86	23	30	23	88
	460-3-60	STD	9	15	9	41	10	15	10	42
		MED	10	15	9	42	11	15	10	43
		HIGH	10	15	9	42	11	15	10	43
	575-3-60	STD	7	15	6	40	9	15	8	42
		MED	7	15	6	41	9	15	9	43
		HIGH	7	15	7	41	9	15	9	43
048	208/230-1-60	STD	31	50	29	140	33	50	32	142
		MED	33	50	31	143	34	50	33	145
		HIGH	35	50	34	146	37	50	37	148
	208/230-3-60	STD	24	30	23	93	25	30	25	95
		MED	25	30	24	96	27	40	27	98
		HIGH	24	30	23	94	26	30	26	96
	460-3-60	STD	10	15	9	45	11	15	11	46
		MED	11	15	10	45	12	15	11	46
		HIGH	11	15	11	46	12	15	12	47
	575-3-60	STD	8	15	7	37	10	15	10	39
		MED	9	15	8	37	10	15	10	39
		HIGH	9	15	9	38	11	15	11	40
060	208/230-1-60	STD	39	60	37	157	41	60	39	159
		MED	41	60	40	160	43	60	42	162
	208/230-3-60	STD	28	40	27	123	30	45	30	125
		MED	31	45	30	126	32	45	32	128
		HIGH	28	40	27	123	30	45	30	125
	460-3-60	STD	13	15	12	56	14	20	13	57
		MED	13	20	12	57	14	20	13	58
		HIGH	14	20	13	58	15	20	14	59
	575-3-60	STD	10	15	9	43	12	15	11	45
		MED	10	15	9	43	12	15	12	45
		HIGH	11	15	10	45	13	15	12	47
	072	208/230-3-60	STD	32	45	31	151	34	50	33
MED			28	45	27	146	30	45	29	148
HIGH			30	45	29	149	32	45	31	151
460-3-60		STD	14	20	13	71	15	20	14	72
		MED	14	20	13	71	15	20	14	72
		HIGH	15	20	14	72	16	20	15	73
575-3-60		STD	11	15	10	59	13	15	12	61
		MED	11	15	10	60	13	15	12	62
		HIGH	11	15	11	61	13	15	13	63

# Electrical data (cont)

## RGV/RAV036-072 MCA MOCP ELECTRICAL DATA (cont)

RGV UNIT SIZE	NOM. V-PH-Hz	IFM TYPE	w/ POWERED CONVENIENCE OUTLET							
			NO POWER EXHAUST				W/ POWER EXHAUST (POWERED FROM UNIT)			
			MCA	FUSE OR HACR BREAKER	DISCONNECT SIZE		MCA	FUSE OR HACR BREAKER	DISCONNECT SIZE	
FLA	LRA	FLA			LRA					
036	208/230-3-60	STD	23	30	23	86	25	30	25	88
		MED	24	30	24	88	26	30	27	90
		HIGH	26	30	26	91	28	30	28	93
	460-3-60	STD	12	15	11	43	13	15	12	44
		MED	12	15	12	44	13	15	13	45
		HIGH	12	15	12	44	13	15	13	45
	575-3-60	STD	8	15	8	42	10	15	10	44
		MED	9	15	8	43	11	15	10	45
		HIGH	9	15	9	43	11	15	11	45
048	208/230-3-60	STD	28	40	28	98	30	40	30	100
		MED	30	40	30	101	32	45	32	103
		HIGH	29	40	29	99	31	40	31	101
	460-3-60	STD	12	15	12	47	13	15	13	48
		MED	13	15	12	47	14	15	13	48
		HIGH	14	15	13	48	15	20	14	49
	575-3-60	STD	10	15	9	39	12	15	12	41
		MED	10	15	10	39	12	15	12	41
		HIGH	11	15	11	40	13	15	13	42
060	208/230-3-60	STD	33	45	33	128	35	50	35	130
		MED	35	50	36	131	37	50	38	133
		HIGH	33	45	33	128	35	50	35	130
	460-3-60	STD	15	20	14	58	16	20	15	59
		MED	15	20	15	59	16	20	16	60
		HIGH	16	20	16	60	17	20	17	61
	575-3-60	STD	11	15	11	45	13	15	13	47
		MED	12	15	11	45	14	15	13	47
		HIGH	12	15	12	47	14	20	14	49
072	208/230-3-60	STD	36	50	36	156	38	50	39	158
		MED	33	50	33	151	35	50	35	153
		HIGH	35	50	35	154	37	50	37	156
	460-3-60	STD	16	20	15	73	17	20	16	74
		MED	16	20	16	73	17	25	17	74
		HIGH	17	20	16	74	18	25	18	75
	575-3-60	STD	12	15	12	61	14	20	14	63
		MED	13	15	12	62	15	20	14	64
		HIGH	13	15	13	63	15	20	15	65

**RAV036 MCA MOCP ELECTRICAL DATA**

RAV UNIT SIZE	NOM. V-Ph-Hz	IFM TYPE	ELECTRIC HEATER			NO CONVENIENCE OUTLET or UNPOWERED CONVENIENCE OUTLET							
			CRHEATER ***A00	NOM (kW)	FLA	NO POWER EXHAUST			w/ POWER EXHAUST (powered from unit)				
						MCA	FUSE OR HACR BRKR	DISCONNECT SIZE		MCA	FUSE OR HACR BRKR	DISCONNECT SIZE	
			FLA	LRA					FLA			LRA	
036	208/230-1-60	STD	NONE	—	—	24	30	23	92	26	30	25	94
			323A	3.3/4.4	15.9/18.3	24/27	30/30	23/24	92/92	26/29	30/30	25/27	94/94
			324A	4.9/6.5	23.5/27.1	34/38	35/40	30/35	92/92	36/40	40/45	33/37	94/94
			325A	6.5/8.7	31.4/36.3	43/50	45/50	40/45	92/92	46/52	50/60	42/47	94/94
			326A	7.9/10.5	37.9/43.8	52/59	60/60	47/54	92/92	54/61	60/70	49/56	94/94
			327A	9.8/13.0	46.9/54.2	63/72	70/80	57/66	92/92	65/74	70/80	60/68	94/94
		MED	NONE	—	—	26	30	25	94	28	40	27	96
			323A	3.3/4.4	15.9/18.3	26/29	30/30	25/26	94/94	28/31	40/40	27/28	96/96
			324A	4.9/6.5	23.5/27.1	35/40	40/40	32/36	94/94	38/42	40/45	34/39	96/96
			325A	6.5/8.7	31.4/36.3	45/51	45/60	41/47	94/94	48/54	50/60	43/49	96/96
			326A	7.9/10.5	37.9/43.8	53/61	60/70	49/56	94/94	56/63	60/70	51/58	96/96
			327A	9.8/13.0	46.9/54.2	65/74	70/80	59/68	94/94	67/76	70/80	61/70	96/96
		HIGH	NONE	—	—	27	40	26	97	29	40	29	99
			323A	3.3/4.4	15.9/18.3	28/31	40/40	26/28	97/97	30/33	40/40	29/30	99/99
			324A	4.9/6.5	23.5/27.1	37/42	40/45	34/38	97/97	40/44	40/45	36/40	99/99
			325A	6.5/8.7	31.4/36.3	47/53	50/60	43/49	97/97	50/56	50/60	45/51	99/99
			326A	7.9/10.5	37.9/43.8	55/63	60/70	51/57	97/97	58/65	60/70	53/60	99/99
			327A	9.8/13.0	46.9/54.2	67/76	70/80	61/69	97/97	69/78	70/80	63/72	99/99
	208/230-3-60	STD	NONE	—	—	18	25	17	81	20	25	19	83
			323A	3.3/4.4	9.2/10.6	18/18	25/25	17/17	81/81	20/20	25/25	19/19	83/83
			324A	4.9/6.5	13.6/15.6	21/24	25/25	19/21	81/81	24/26	25/30	21/24	83/83
			325A	6.5/8.7	18.1/20.9	27/30	30/30	24/27	81/81	29/33	30/35	26/30	83/83
			326A	7.9/10.5	21.9/25.3	32/36	35/40	29/33	81/81	34/38	35/40	31/35	83/83
			328A	12.0/16.0	33.4/38.5	46/52	50/60	42/48	81/81	48/55	50/60	44/50	83/83
		MED	NONE	—	—	19	25	19	83	21	30	21	85
			323A	3.3/4.4	9.2/10.6	19/19	25/25	19/19	83/83	21/22	30/30	21/21	85/85
			324A	4.9/6.5	13.6/15.6	23/26	25/30	21/23	83/83	25/28	30/30	23/25	85/85
			325A	6.5/8.7	18.1/20.9	29/32	30/35	26/29	83/83	31/35	35/35	28/31	85/85
			326A	7.9/10.5	21.9/25.3	33/38	35/40	30/34	83/83	36/40	40/40	33/36	85/85
			328A	12.0/16.0	33.4/38.5	48/54	50/60	44/49	83/83	50/57	50/60	46/52	85/85
		HIGH	NONE	—	—	21	30	21	86	23	30	23	88
			323A	3.3/4.4	9.2/10.6	21/21	30/30	21/21	86/86	23/24	30/30	23/23	88/88
			324A	4.9/6.5	13.6/15.6	25/28	30/30	23/25	86/86	27/30	30/30	25/27	88/88
			325A	6.5/8.7	18.1/20.9	31/34	35/35	28/31	86/86	33/37	35/40	30/33	88/88
			326A	7.9/10.5	21.9/25.3	35/40	35/40	32/36	86/86	38/42	40/45	34/38	88/88
			328A	12.0/16.0	33.4/38.5	50/56	50/60	45/51	86/86	52/59	60/60	48/53	88/88
	460-3-60	STD	NONE	—	—	9	15	9	41	10	15	10	42
			333A	6.0	7.2	10	15	9	41	12	15	10	42
			334A	8.8	10.6	15	15	13	41	16	20	14	42
			335A	11.5	13.8	19	20	17	41	20	20	18	42
			336A	14.0	16.8	22	25	20	41	24	25	21	42
			NONE	—	—	10	15	9	42	11	15	10	43
		MED	333A	6.0	7.2	11	15	10	42	12	15	11	43
			334A	8.8	10.6	15	15	14	42	16	20	15	43
			335A	11.5	13.8	19	20	17	42	20	25	18	43
			336A	14.0	16.8	23	25	21	42	24	25	22	43
			NONE	—	—	10	15	9	42	11	15	10	43
			333A	6.0	7.2	11	15	10	42	13	15	11	43
HIGH		334A	8.8	10.6	16	20	14	42	17	20	15	43	
		335A	11.5	13.8	20	20	18	42	21	25	19	43	
		336A	14.0	16.8	23	25	21	42	25	25	22	43	
		NONE	—	—	7	15	6	40	9	15	8	42	
		339A	10.0	9.6	13	15	12	40	16	20	14	42	
		340A	15.0	14.4	19	20	17	40	22	25	20	42	
575-3-60	STD	NONE	—	—	7	15	6	41	9	15	9	43	
		339A	10.0	9.6	14	15	12	41	16	20	14	43	
		340A	15.0	14.4	20	20	18	41	22	25	20	43	
	MED	NONE	—	—	7	15	6	41	9	15	9	43	
		339A	10.0	9.6	14	15	12	41	16	20	14	43	
		340A	15.0	14.4	20	20	18	41	22	25	20	43	
HIGH	NONE	—	—	7	15	7	41	9	15	9	43		
	339A	10.0	9.6	14	15	13	41	17	20	15	43		
	340A	15.0	14.4	20	20	18	41	23	25	20	43		

# Electrical data (cont)

## RAV036 MCA MOCP ELECTRICAL DATA (cont)

RAV UNIT SIZE	NOM. V-Ph-Hz	IFM TYPE	ELECTRIC HEATER			w/ POWERED CONVENIENCE OUTLET							
			CRHEATER ***A00	NOM (kW)	FLA	NO POWER EXHAUST			w/ POWER EXHAUST (powered from unit)				
						MCA	FUSE OR HACR BRKR	DISCONNECT SIZE		MCA	FUSE OR HACR BRKR	DISCONNECT SIZE	
							FLA	LRA			FLA	LRA	
036	208/230-3-60	STD	NONE	—	—	23	30	23	86	25	30	25	88
			323A	3.3/4.4	9.2/10.6	23/23	30/30	23/23	86/86	25/26	30/30	25/25	88/88
			324A	4.9/6.5	13.6/15.6	27/30	30/30	25/27	86/86	30/32	30/35	27/29	88/88
			325A	6.5/8.7	18.1/20.9	33/36	35/40	30/33	86/86	35/39	35/40	32/35	88/88
			326A	7.9/10.5	21.9/25.3	38/42	40/45	34/38	86/86	40/44	40/45	36/40	88/88
		328A	12.0/16.0	33.4/38.5	52/58	60/60	47/53	86/86	54/61	60/70	50/55	88/88	
		MED	NONE	—	—	24	30	24	88	26	30	27	90
			323A	3.3/4.4	9.2/10.6	24/25	30/30	24/24	88/88	26/28	30/30	27/27	90/90
			324A	4.9/6.5	13.6/15.6	29/32	30/35	26/29	88/88	31/34	35/35	29/31	90/90
			325A	6.5/8.7	18.1/20.9	35/38	35/40	32/35	88/88	37/41	40/45	34/37	90/90
			326A	7.9/10.5	21.9/25.3	39/44	40/45	36/40	88/88	42/46	45/50	38/42	90/90
		328A	12.0/16.0	33.4/38.5	54/60	60/60	49/55	88/88	56/63	60/70	51/57	90/90	
		HIGH	NONE	—	—	26	30	26	91	28	30	28	93
			323A	3.3/4.4	9.2/10.6	26/27	30/30	26/26	91/91	28/30	30/30	28/28	93/93
			324A	4.9/6.5	13.6/15.6	31/34	35/35	28/30	91/91	33/36	35/40	30/33	93/93
	325A		6.5/8.7	18.1/20.9	37/40	40/40	33/37	91/91	39/43	40/45	36/39	93/93	
	326A		7.9/10.5	21.9/25.3	41/46	45/50	38/42	91/91	44/48	45/50	40/44	93/93	
	328A	12.0/16.0	33.4/38.5	56/62	60/70	51/57	91/91	58/65	60/70	53/59	93/93		
	460-3-60	STD	NONE	—	—	12	15	11	43	13	15	12	44
			333A	6.0	7.2	13	15	12	43	14	15	13	44
			334A	8.8	10.6	17	20	16	43	19	20	17	44
			335A	11.5	13.8	21	25	19	43	23	25	20	44
			336A	14.0	16.8	25	25	23	43	26	30	24	44
		MED	NONE	—	—	12	15	12	44	13	15	13	45
			333A	6.0	7.2	14	15	12	44	15	15	13	45
			334A	8.8	10.6	18	20	16	44	19	20	17	45
			335A	11.5	13.8	22	25	20	44	23	25	21	45
			336A	14.0	16.8	26	30	23	44	27	30	24	45
		HIGH	NONE	—	—	12	15	12	44	13	15	13	45
			333A	6.0	7.2	14	15	13	44	15	15	14	45
			334A	8.8	10.6	18	20	16	44	20	20	18	45
			335A	11.5	13.8	22	25	20	44	24	25	21	45
			336A	14.0	16.8	26	30	24	44	27	30	25	45
	575-3-60	STD	NONE	—	—	8	15	8	42	10	15	10	44
			339A	10.0	9.6	16	20	14	42	18	20	16	44
			340A	15.0	14.4	22	25	19	42	24	25	22	44
MED		NONE	—	—	9	15	8	43	11	15	10	45	
		339A	10.0	9.6	16	20	14	43	18	20	16	45	
		340A	15.0	14.4	22	25	20	43	24	25	22	45	
HIGH		NONE	—	—	9	15	9	43	11	15	11	45	
		339A	10.0	9.6	16	20	15	43	19	20	17	45	
		340A	15.0	14.4	22	25	20	43	25	25	22	45	

**RAV048 MCA MOCP ELECTRICAL DATA**

RAV UNIT SIZE	NOM. V-Ph-Hz	IFM TYPE	ELECTRIC HEATER			NO CONVENIENCE OUTLET or UNPOWERED CONVENIENCE OUTLET							
			CRHEATER ***A00	NOM (kW)	FLA	NO POWER EXHAUST				w/ POWER EXHAUST (powered from unit)			
						MCA	FUSE OR HACR BRKR	DISCONNECT SIZE		MCA	FUSE OR HACR BRKR	DISCONNECT SIZE	
								FLA	LRA			FLA	LRA
048	208/230-1-60	STD	NONE	—	—	31	50	29	140	33	50	32	142
			323A	3.3/4.4	15.9/18.3	31/31	50/50	29/29	140/140	33/33	50/50	32/32	142/142
			325A	6.5/8.7	31.4/36.3	45/51	50/60	41/47	140/140	48/54	50/60	43/49	142/142
			327A	9.8/13.0	46.9/54.2	65/74	70/80	59/68	140/140	67/76	70/80	61/70	142/142
			329A	13.1/17.4	62.8/72.5	85/97	90/100	77/89	140/140	87/99	90/100	80/91	142/142
			330A*	14.4/19.2	69.3/80.0	93/106	100/110	85/97	140/140	95/108	100/110	87/99	142/142
		331A†	15.8/21.0	75.8/87.5	101/115	110/125	92/106	140/140	103/118	110/125	95/108	142/142	
		NONE	—	—	33	50	31	143	34	50	33	145	
		323A	3.3/4.4	15.9/18.3	33/33	50/50	31/31	143/143	34/34	50/50	33/33	145/145	
		325A	6.5/8.7	31.4/36.3	47/53	50/60	43/49	143/143	50/56	50/60	45/51	145/145	
		327A	9.8/13.0	46.9/54.2	67/76	70/80	61/69	143/143	69/78	70/80	63/72	145/145	
		329A	13.1/17.4	62.8/72.5	87/99	90/100	79/90	143/143	89/101	90/110	81/93	145/145	
		330A*	14.4/19.2	69.3/80.0	95/108	100/110	87/99	143/143	97/110	100/125	89/101	145/145	
		331A†	15.8/21.0	75.8/87.5	103/117	110/125	94/108	143/143	105/120	110/125	96/110	145/145	
		NONE	—	—	35	50	34	146	37	50	37	148	
		323A	3.3/4.4	15.9/18.3	35/35	50/50	34/34	146/146	37/37	50/50	37/37	148/148	
		325A	6.5/8.7	31.4/36.3	51/57	60/60	46/52	146/146	53/59	60/60	48/54	148/148	
		327A	9.8/13.0	46.9/54.2	70/79	70/80	64/72	146/146	72/82	80/90	66/75	148/148	
	329A	13.1/17.4	62.8/72.5	90/102	90/110	82/93	146/146	92/104	100/110	85/96	148/148		
	330A*	14.4/19.2	69.3/80.0	98/111	100/125	90/102	146/146	100/114	110/125	92/104	148/148		
	331A†	15.8/21.0	75.8/87.5	106/121	110/125	97/111	146/146	109/123	110/125	99/113	148/148		
	NONE	—	—	24	30	23	93	25	30	25	95		
	324A	4.9/6.5	13.6/15.6	24/26	30/30	23/23	93/93	25/28	30/30	25/25	95/95		
	325A	6.5/8.7	18.1/20.9	29/32	30/35	26/29	93/93	31/35	35/35	28/31	95/95		
	328A	12.0/16.0	33.4/38.5	48/54	50/60	44/49	93/93	50/57	50/60	46/52	95/95		
	330A*	14.4/19.2	40.0/46.2	56/64	60/70	51/58	93/93	58/66	60/70	53/60	95/95		
	331A†	15.8/21.0	43.8/50.5	61/69	70/70	56/63	93/93	63/72	70/80	58/65	95/95		
	NONE	—	—	25	30	24	96	27	40	27	98		
	324A	4.9/6.5	13.6/15.6	25/28	30/30	24/25	96/96	27/30	40/40	27/27	98/98		
	325A	6.5/8.7	18.1/20.9	31/34	35/35	28/31	96/96	33/37	40/40	30/33	98/98		
	328A	12.0/16.0	33.4/38.5	50/56	50/60	45/51	96/96	52/59	60/60	48/53	98/98		
	330A*	14.4/19.2	40.0/46.2	58/66	60/70	53/60	96/96	60/68	60/70	55/62	98/98		
	331A†	15.8/21.0	43.8/50.5	63/71	70/80	57/65	96/96	65/74	70/80	60/67	98/98		
	NONE	—	—	24	30	23	94	26	30	26	96		
	324A	4.9/6.5	13.6/15.6	24/26	30/30	23/24	94/94	26/29	30/30	26/26	96/96		
	325A	6.5/8.7	18.1/20.9	29/33	30/35	27/30	94/94	32/35	35/35	29/32	96/96		
328A	12.0/16.0	33.4/38.5	49/55	50/60	44/50	94/94	51/57	60/60	46/52	96/96			
330A*	14.4/19.2	40.0/46.2	57/65	60/70	52/59	94/94	59/67	60/70	54/61	96/96			
331A†	15.8/21.0	43.8/50.5	62/70	70/70	56/64	94/94	64/72	70/80	58/66	96/96			
NONE	—	—	10	15	9	45	11	15	11	46			
333A	6.0	7.2	11	15	10	45	12	15	11	46			
335A	11.5	13.8	19	20	17	45	20	25	18	46			
336A	14.0	16.8	23	25	21	45	24	25	22	46			
337A	21.5	25.9	34	35	31	45	36	40	32	46			
NONE	—	—	11	15	10	45	12	15	11	46			
333A	6.0	7.2	11	15	10	45	13	15	11	46			
335A	11.5	13.8	20	20	18	45	21	25	19	46			
336A	14.0	16.8	23	25	21	45	25	25	22	46			
337A	21.5	25.9	35	35	32	45	36	40	33	46			
NONE	—	—	11	15	11	46	12	15	12	47			
333A	6.0	7.2	12	15	11	46	14	15	12	47			
335A	11.5	13.8	21	25	19	46	22	25	20	47			
336A	14.0	16.8	24	25	22	46	26	30	23	47			
337A	21.5	25.9	36	40	33	46	37	40	34	47			
460-3-60	STD	NONE	—	—	10	15	9	45	11	15	11	46	
		333A	6.0	7.2	11	15	10	45	12	15	11	46	
		335A	11.5	13.8	19	20	17	45	20	25	18	46	
		336A	14.0	16.8	23	25	21	45	24	25	22	46	
		337A	21.5	25.9	34	35	31	45	36	40	32	46	
		NONE	—	—	11	15	10	45	12	15	11	46	
	333A	6.0	7.2	11	15	10	45	13	15	11	46		
	335A	11.5	13.8	20	20	18	45	21	25	19	46		
	336A	14.0	16.8	23	25	21	45	25	25	22	46		
	337A	21.5	25.9	35	35	32	45	36	40	33	46		
	NONE	—	—	11	15	11	46	12	15	12	47		
	333A	6.0	7.2	12	15	11	46	14	15	12	47		
	335A	11.5	13.8	21	25	19	46	22	25	20	47		
	336A	14.0	16.8	24	25	22	46	26	30	23	47		
	337A	21.5	25.9	36	40	33	46	37	40	34	47		

# Electrical data (cont)

## RAV048 MCA MOCP ELECTRICAL DATA (cont)

RAV UNIT SIZE	NOM. V-Ph-Hz	IFM TYPE	ELECTRIC HEATER			NO CONVENIENCE OUTLET or UNPOWERED CONVENIENCE OUTLET							
			CRHEATER ***A00	NOM (kW)	FLA	NO POWER EXHAUST				w/ POWER EXHAUST (powered from unit)			
						MCA	FUSE OR HACR BRKR	DISCONNECT SIZE		MCA	FUSE OR HACR BRKR	DISCONNECT SIZE	
FLA	LRA	FLA	LRA										
048 (cont)	575-3-60	STD	NONE	—	—	8	15	7	37	10	15	10	39
			339A	10.0	9.6	14	15	12	37	16	20	14	39
			340A	15.0	14.4	20	20	18	37	22	25	20	39
		MED	NONE	—	—	9	15	8	37	10	15	10	39
			339A	10.0	9.6	14	15	13	37	17	20	15	39
			340A	15.0	14.4	20	20	18	37	23	25	20	39
		HIGH	NONE	—	—	9	15	9	38	11	15	11	40
			339A	10.0	9.6	15	15	14	38	18	20	16	40
			340A	15.0	14.4	21	25	19	38	24	25	21	40

\*Do not use with size 048 horizontal supply duct configuration units.

†Do not use with size 048 vertical supply duct configuration units.

**RAV048 MCA MOCP ELECTRICAL DATA (cont)**

RAV UNIT SIZE	NOM. V-Ph-Hz	IFM TYPE	ELECTRIC HEATER			w/ POWERED CONVENIENCE OUTLET							
			CRHEATER ***A00	NOM (kW)	FLA	NO POWER EXHAUST			w/ POWER EXHAUST (powered from unit)				
						MCA	FUSE OR HACR BRKR	DISCONNECT SIZE		MCA	FUSE OR HACR BRKR	DISCONNECT SIZE	
							FLA	LRA			FLA	LRA	
048	208/230-3-60	STD	NONE	—	—	28	40	28	98	30	40	30	100
			324A	4.9/6.5	13.6/15.6	29/32	40/40	28/29	98/98	31/34	40/40	30/31	100/100
			325A	6.5/8.7	18.1/20.9	35/38	40/40	32/35	98/98	37/41	40/45	34/37	100/100
			328A	12.0/16.0	33.4/38.5	54/60	60/60	49/55	98/98	56/63	60/70	51/57	100/100
			330A*	14.4/19.2	40.0/46.2	62/70	70/70	57/64	98/98	64/72	70/80	59/66	100/100
			331A†	15.8/21.0	43.8/50.5	67/75	70/80	61/69	98/98	69/78	70/80	63/71	100/100
		MED	NONE	—	—	30	40	30	101	32	45	32	103
			324A	4.9/6.5	13.6/15.6	31/34	40/40	30/30	101/101	33/36	45/45	32/33	103/103
			325A	6.5/8.7	18.1/20.9	37/40	40/40	33/37	101/101	39/43	45/45	36/39	103/103
			328A	12.0/16.0	33.4/38.5	56/62	60/70	51/57	101/101	58/65	60/70	53/59	103/103
			330A*	14.4/19.2	40.0/46.2	64/72	70/80	59/66	101/101	66/74	70/80	61/68	103/103
			331A†	15.8/21.0	43.8/50.5	69/77	70/80	63/71	101/101	71/80	80/80	65/73	103/103
		HIGH	NONE	—	—	29	40	29	99	31	40	31	101
			324A	4.9/6.5	13.6/15.6	30/32	40/40	29/29	99/99	32/35	40/40	31/32	101/101
			325A	6.5/8.7	18.1/20.9	35/39	40/40	32/35	99/99	38/41	40/45	34/38	101/101
			328A	12.0/16.0	33.4/38.5	55/61	60/70	50/56	99/99	57/63	60/70	52/58	101/101
			330A*	14.4/19.2	40.0/46.2	63/71	70/80	57/65	99/99	65/73	70/80	60/67	101/101
			331A†	15.8/21.0	43.8/50.5	68/76	70/80	62/69	99/99	70/78	70/80	64/72	101/101
	460-3-60	STD	NONE	—	—	12	15	12	47	13	15	13	48
			333A	6.0	7.2	14	15	12	47	15	15	13	48
			335A	11.5	13.8	22	25	20	47	23	25	21	48
			336A	14.0	16.8	26	30	23	47	27	30	24	48
			337A	21.5	25.9	37	40	34	47	38	40	35	48
			NONE	—	—	13	15	12	47	14	15	13	48
		MED	333A	6.0	7.2	14	15	13	47	15	15	14	48
			335A	11.5	13.8	22	25	20	47	24	25	21	48
			336A	14.0	16.8	26	30	24	47	27	30	25	48
			337A	21.5	25.9	37	40	34	47	39	40	35	48
			NONE	—	—	14	15	13	48	15	20	14	49
			333A	6.0	7.2	15	15	14	48	16	20	15	49
		HIGH	335A	11.5	13.8	23	25	21	48	25	25	22	49
			336A	14.0	16.8	27	30	25	48	28	30	26	49
			337A	21.5	25.9	39	40	35	48	40	40	36	49
			NONE	—	—	10	15	9	39	12	15	12	41
			339A	10.0	9.6	16	20	14	39	18	20	16	41
			340A	15.0	14.4	22	25	20	39	24	25	22	41
575-3-60	STD	NONE	—	—	10	15	10	39	12	15	12	41	
		339A	10.0	9.6	16	20	15	39	19	20	17	41	
		340A	15.0	14.4	22	25	20	39	25	25	22	41	
	MED	NONE	—	—	11	15	11	40	13	15	13	42	
		339A	10.0	9.6	17	20	16	40	20	20	18	42	
		340A	15.0	14.4	23	25	21	40	26	30	23	42	

\*Do not use with size 048 horizontal supply duct configuration units.

†Do not use with size 048 vertical supply duct configuration units.

# Electrical data (cont)

## RAV060 MCA MOCP ELECTRICAL DATA

RAV UNIT SIZE	NOM. V-Ph-Hz	IFM TYPE	ELECTRIC HEATER			NO CONVENIENCE OUTLET or UNPOWERED CONVENIENCE OUTLET							
			CRHEATER ***A00	NOM (kW)	FLA	NO POWER EXHAUST			w/ POWER EXHAUST (powered from unit)				
						MCA	FUSE OR HACR BRKR	DISCONNECT SIZE	MCA	FUSE OR HACR BRKR	DISCONNECT SIZE		
						FLA	LRA			FLA	LRA		
060	208/230-1-60	STD	NONE	—	—	39	60	37	157	41	60	39	159
			324A	4.9/6.5	23.5/27.1	39/42	60/60	37/39	157/157	41/45	60/60	39/41	159/159
			325A	6.5/8.7	31.4/36.3	48/54	60/60	43/49	157/157	50/56	60/60	46/51	159/159
			327A	9.8/13.0	46.9/54.2	67/76	70/80	61/70	157/157	69/79	70/80	63/72	159/159
			329A	13.1/17.4	62.8/72.5	87/99	90/100	80/91	157/157	89/101	90/110	82/93	159/159
			331A	15.8/21.0	75.8/87.5	103/118	110/125	95/108	157/157	106/120	110/125	97/110	159/159
		MED	NONE	—	—	41	60	40	160	43	60	42	162
			324A	4.9/6.5	23.5/27.1	41/45	60/60	40/41	160/160	43/47	60/60	42/43	162/162
			325A	6.5/8.7	31.4/36.3	50/57	60/60	46/52	160/160	53/59	60/60	48/54	162/162
			327A	9.8/13.0	46.9/54.2	70/79	70/80	64/72	160/160	72/81	80/90	66/74	162/162
			329A	13.1/17.4	62.8/72.5	90/102	90/110	82/93	160/160	92/104	100/110	84/95	162/162
			331A	15.8/21.0	75.8/87.5	106/121	110/125	97/111	160/160	108/123	110/125	99/113	162/162
	208/230-3-60	STD	NONE	—	—	28	40	27	123	30	45	30	125
			324A	4.9/6.5	13.6/15.6	28/28	40/40	27/27	123/123	30/30	45/45	30/30	125/125
			326A	7.9/10.5	21.9/25.3	36/40	40/40	33/36	123/123	38/42	45/45	35/39	125/125
			328A	12.0/16.0	33.4/38.5	50/57	50/60	46/52	123/123	53/59	60/60	48/54	125/125
			331A	15.8/21.0	43.8/50.5	63/72	70/80	58/65	123/123	66/74	70/80	60/68	125/125
			332A	18.4/24.5	51.1/58.9	72/82	80/90	66/75	123/123	75/84	80/90	68/77	125/125
		MED	NONE	—	—	31	45	30	126	32	45	32	128
			324A	4.9/6.5	13.6/15.6	31/31	45/45	30/30	126/126	32/33	45/45	32/32	128/128
			326A	7.9/10.5	21.9/25.3	39/43	45/45	35/39	126/126	41/45	45/45	37/41	128/128
			328A	12.0/16.0	33.4/38.5	53/59	60/60	48/54	126/126	55/62	60/70	50/56	128/128
			331A	15.8/21.0	43.8/50.5	66/74	70/80	60/68	126/126	68/77	70/80	62/70	128/128
			332A	18.4/24.5	51.1/58.9	75/85	80/90	69/78	126/126	77/87	80/90	71/80	128/128
	HIGH	NONE	—	—	28	40	27	123	30	45	30	125	
		324A	4.9/6.5	13.6/15.6	28/28	40/40	27/27	123/123	30/30	45/45	30/30	125/125	
		326A	7.9/10.5	21.9/25.3	36/40	40/40	33/36	123/123	38/42	45/45	35/39	125/125	
		328A	12.0/16.0	33.4/38.5	50/57	50/60	46/52	123/123	53/59	60/60	48/54	125/125	
		331A	15.8/21.0	43.8/50.5	63/72	70/80	58/65	123/123	66/74	70/80	60/68	125/125	
		332A	18.4/24.5	51.1/58.9	72/82	80/90	66/75	123/123	75/84	80/90	68/77	125/125	
	460-3-60	STD	NONE	—	—	13	15	12	56	14	20	13	57
			333A	6.0	7.2	13	15	12	56	14	20	13	57
			335A	11.5	13.8	20	20	18	56	21	25	19	57
			336A	14.0	16.8	23	25	21	56	25	25	22	57
			337A	21.5	25.9	35	35	32	56	36	40	33	57
			338A	24.0	28.9	38	40	35	56	40	40	36	57
		MED	NONE	—	—	13	20	12	57	14	20	13	58
			333A	6.0	7.2	13	20	12	57	14	20	13	58
			335A	11.5	13.8	20	20	18	57	21	25	19	58
			336A	14.0	16.8	24	25	22	57	25	25	23	58
			337A	21.5	25.9	35	35	32	57	36	40	33	58
			338A	24.0	28.9	39	40	35	57	40	40	37	58
		HIGH	NONE	—	—	14	20	13	58	15	20	14	59
			333A	6.0	7.2	14	20	13	58	15	20	14	59
			335A	11.5	13.8	21	25	19	58	23	25	20	59
			336A	14.0	16.8	25	25	23	58	26	30	24	59
			337A	21.5	25.9	36	40	33	58	38	40	34	59
			338A	24.0	28.9	40	40	37	58	41	45	38	59
575-3-60	STD	NONE	—	—	10	15	9	43	12	15	11	45	
		340A	15.0	14.4	20	20	18	43	23	25	20	45	
		341A	25.0	24.1	32	35	29	43	35	35	32	45	
	MED	NONE	—	—	10	15	9	43	12	15	12	45	
		340A	15.0	14.4	21	25	19	43	23	25	21	45	
		341A	25.0	24.1	33	35	30	43	35	35	32	45	
	HIGH	NONE	—	—	11	15	10	45	13	15	12	47	
		340A	15.0	14.4	22	25	19	45	24	25	22	47	
		341A	25.0	24.1	34	35	31	45	36	40	33	47	

**RAV060 MCA MOCP ELECTRICAL DATA (cont)**

RAV UNIT SIZE	NOM. V-Ph-Hz	IFM TYPE	ELECTRIC HEATER			w/ POWERED CONVENIENCE OUTLET							
			CRHEATER ***A00	NOM (kW)	FLA	NO POWER EXHAUST			w/ POWER EXHAUST (powered from unit)				
						MCA	FUSE OR HACR BRKR	DISCONNECT SIZE		MCA	FUSE OR HACR BRKR	DISCONNECT SIZE	
					FLA	LRA	MCA	FLA	LRA	MCA	FLA	LRA	
060	208/230-3-60	STD	NONE	—	—	33	45	33	128	35	50	35	130
			324A	4.9/6.5	13.6/15.6	33/34	45/45	33/33	128/128	35/36	50/50	35/35	130/130
			326A	7.9/10.5	21.9/25.3	42/46	45/50	38/42	128/128	44/48	50/50	40/44	130/130
			328A	12.0/16.0	33.4/38.5	56/63	60/70	51/57	128/128	59/65	60/70	53/59	130/130
			331A	15.8/21.0	43.8/50.5	69/78	70/80	63/71	128/128	72/80	80/80	65/73	130/130
			332A	18.4/24.5	51.1/58.9	78/88	80/90	72/81	128/128	81/90	90/100	74/83	130/130
		MED	NONE	—	—	35	50	36	131	37	50	38	133
			324A	4.9/6.5	13.6/15.6	35/37	50/50	36/36	131/131	37/39	50/50	38/38	133/133
			326A	7.9/10.5	21.9/25.3	45/49	50/50	41/45	131/131	47/51	50/60	43/47	133/133
			328A	12.0/16.0	33.4/38.5	59/65	60/70	54/60	131/131	61/68	70/70	56/62	133/133
			331A	15.8/21.0	43.8/50.5	72/80	80/80	66/73	131/131	74/83	80/90	68/76	133/133
			332A	18.4/24.5	51.1/58.9	81/91	90/100	74/83	131/131	83/93	90/100	76/85	133/133
		HIGH	NONE	—	—	33	45	33	128	35	50	35	130
			324A	4.9/6.5	13.6/15.6	33/34	45/45	33/33	128/128	35/36	50/50	35/35	130/130
			326A	7.9/10.5	21.9/25.3	42/46	45/50	38/42	128/128	44/48	50/50	40/44	130/130
			328A	12.0/16.0	33.4/38.5	56/63	60/70	51/57	128/128	59/65	60/70	53/59	130/130
			331A	15.8/21.0	43.8/50.5	69/78	70/80	63/71	128/128	72/80	80/80	65/73	130/130
			332A	18.4/24.5	51.1/58.9	78/88	80/90	72/81	128/128	81/90	90/100	74/83	130/130
	460-3-60	STD	NONE	—	—	15	20	14	58	16	20	15	59
			333A	6.0	7.2	15	20	14	58	16	20	15	59
			335A	11.5	13.8	22	25	20	58	24	25	21	59
			336A	14.0	16.8	26	30	24	58	27	30	25	59
			337A	21.5	25.9	37	40	34	58	39	40	35	59
			338A	24.0	28.9	41	45	37	58	42	45	39	59
		MED	NONE	—	—	15	20	15	59	16	20	16	60
			333A	6.0	7.2	15	20	15	59	16	20	16	60
			335A	11.5	13.8	23	25	21	59	24	25	22	60
			336A	14.0	16.8	27	30	24	59	28	30	25	60
			337A	21.5	25.9	38	40	35	59	39	40	36	60
			338A	24.0	28.9	42	45	38	59	43	45	39	60
		HIGH	NONE	—	—	16	20	16	60	17	20	17	61
			333A	6.0	7.2	16	20	16	60	17	20	17	61
			335A	11.5	13.8	24	25	22	60	25	25	23	61
			336A	14.0	16.8	28	30	25	60	29	30	26	61
			337A	21.5	25.9	39	40	36	60	40	45	37	61
			338A	24.0	28.9	43	45	39	60	44	45	40	61
575-3-60	STD	NONE	—	—	11	15	11	45	13	15	13	47	
		340A	15.0	14.4	22	25	20	45	25	25	22	47	
		341A	25.0	24.1	35	35	31	45	37	40	34	47	
	MED	NONE	—	—	12	15	11	45	14	15	13	47	
		340A	15.0	14.4	23	25	21	45	25	25	23	47	
		341A	25.0	24.1	35	35	32	45	37	40	34	47	
	HIGH	NONE	—	—	12	15	12	47	14	20	14	49	
		340A	15.0	14.4	24	25	21	47	26	30	24	49	
		341A	25.0	24.1	36	40	33	47	38	40	35	49	

# Electrical data (cont)

## RAV072 MCA MOCP ELECTRICAL DATA

RAV UNIT SIZE	NOM. V-Ph-Hz	IFM TYPE	ELECTRIC HEATER			NO CONVENIENCE OUTLET or UNPOWERED CONVENIENCE OUTLET							
			CRHEATER ***A00	NOM (kW)	FLA	NO POWER EXHAUST				w/ POWER EXHAUST (powered from unit)			
						MCA	FUSE OR HACR BRKR	DISCONNECT SIZE		MCA	FUSE OR HACR BRKR	DISCONNECT SIZE	
		FLA	LRA	FLA	LRA								
072	208/230-3-60	STD	NONE	—	—	32	45	31	151	34	50	33	153
			324A	4.9/6.5	13.6/15.6	32/32	45/45	31/31	151/151	34/34	50/50	33/33	153/153
			326A	7.9/10.5	21.9/25.3	38/42	45/45	34/38	151/151	40/44	50/50	36/40	153/153
			328A	12.0/16.0	33.4/38.5	52/58	60/60	47/53	151/151	54/61	60/70	50/55	153/153
			331A	15.8/21.0	43.8/50.5	65/73	70/80	59/67	151/151	67/76	70/80	62/69	153/153
			332A	18.4/24.5	51.1/58.9	74/84	80/90	68/77	151/151	76/86	80/90	70/79	153/153
		MED	NONE	—	—	28	45	27	146	30	45	29	148
			324A	4.9/6.5	13.6/15.6	28/28	45/45	27/27	146/146	30/30	45/45	29/29	148/148
			326A	7.9/10.5	21.9/25.3	33/38	45/45	30/34	146/146	36/40	45/45	33/36	148/148
			328A	12.0/16.0	33.4/38.5	48/54	50/60	44/49	146/146	50/57	50/60	46/52	148/148
			331A	15.8/21.0	43.8/50.5	61/69	70/70	56/63	146/146	63/72	70/80	58/65	148/148
			332A	18.4/24.5	51.1/58.9	70/80	70/80	64/73	146/146	72/82	80/90	66/75	148/148
		HIGH	NONE	—	—	30	45	29	149	32	45	31	151
			324A	4.9/6.5	13.6/15.6	30/30	45/45	29/29	149/149	32/32	45/45	31/31	151/151
			326A	7.9/10.5	21.9/25.3	36/40	45/45	33/36	149/149	38/42	45/45	35/39	151/151
			328A	12.0/16.0	33.4/38.5	50/57	50/60	46/52	149/149	53/59	60/60	48/54	151/151
			331A	15.8/21.0	43.8/50.5	63/72	70/80	58/65	149/149	66/74	70/80	60/68	151/151
			332A	18.4/24.5	51.1/58.9	72/82	80/90	66/75	149/149	75/84	80/90	68/77	151/151
	460-3-60	STD	NONE	—	—	14	20	13	71	15	20	14	72
			333A	6.0	7.2	14	20	13	71	15	20	14	72
			335A	11.5	13.8	20	20	18	71	21	25	19	72
			336A	14.0	16.8	24	25	21	71	25	25	23	72
			337A	21.5	25.9	35	35	32	71	36	40	33	72
			338A	24.0	28.9	39	40	35	71	40	40	36	72
		MED	NONE	—	—	14	20	13	71	15	20	14	72
			333A	6.0	7.2	14	20	13	71	15	20	14	72
			335A	11.5	13.8	20	25	18	71	22	25	20	72
			336A	14.0	16.8	24	25	22	71	25	30	23	72
			337A	21.5	25.9	36	40	32	71	37	40	33	72
			338A	24.0	28.9	39	40	36	71	41	45	37	72
		HIGH	NONE	—	—	15	20	14	72	16	20	15	73
			333A	6.0	7.2	15	20	14	72	16	20	15	73
			335A	11.5	13.8	21	25	19	72	23	25	20	73
			336A	14.0	16.8	25	25	23	72	26	30	24	73
			337A	21.5	25.9	36	40	33	72	38	40	34	73
			338A	24.0	28.9	40	40	37	72	41	45	38	73
575-3-60	STD	NONE	—	—	11	15	10	59	13	15	12	61	
		340A	15.0	14.4	21	25	19	59	23	25	21	61	
		341A	25.0	24.1	33	35	30	59	35	35	32	61	
	MED	NONE	—	—	11	15	10	60	13	15	12	62	
		340A	15.0	14.4	21	25	19	60	23	25	21	62	
		341A	25.0	24.1	33	35	30	60	35	40	32	62	
	HIGH	NONE	—	—	11	15	11	61	13	15	13	63	
		340A	15.0	14.4	22	25	19	61	24	25	22	63	
		341A	25.0	24.1	34	35	31	61	36	40	33	63	

**RAV072 MCA MOCP ELECTRICAL DATA (cont)**

RAV UNIT SIZE	NOM. V-Ph-Hz	IFM TYPE	ELECTRIC HEATER			w/ POWERED CONVENIENCE OUTLET							
			CRHEATER ***A00	NOM (kW)	FLA	NO POWER EXHAUST				w/ POWER EXHAUST (powered from unit)			
						MCA	FUSE OR HACR BRKR	DISCONNECT SIZE		MCA	FUSE OR HACR BRKR	DISCONNECT SIZE	
			FLA	LRA					FLA			LRA	
072	208/230-3-60	STD	NONE	—	—	36	50	36	156	38	50	39	158
			324A	4.9/6.5	13.6/15.6	36/36	50/50	36/36	156/156	38/38	50/50	39/39	158/158
			326A	7.9/10.5	21.9/25.3	44/48	50/50	40/44	156/156	46/50	50/50	42/46	158/158
			328A	12.0/16.0	33.4/38.5	58/64	60/70	53/59	156/156	60/67	60/70	55/61	158/158
			331A	15.8/21.0	43.8/50.5	71/79	80/80	65/73	156/156	73/82	80/90	67/75	158/158
			332A	18.4/24.5	51.1/58.9	80/90	80/90	73/82	156/156	82/92	90/100	75/84	158/158
		MED	NONE	—	—	33	50	33	151	35	50	35	153
			324A	4.9/6.5	13.6/15.6	33/33	50/50	33/33	151/151	35/35	50/50	35/35	153/153
			326A	7.9/10.5	21.9/25.3	39/44	50/50	36/40	151/151	42/46	50/50	38/42	153/153
			328A	12.0/16.0	33.4/38.5	54/60	60/60	49/55	151/151	56/63	60/70	51/57	153/153
			331A	15.8/21.0	43.8/50.5	67/75	70/80	61/69	151/151	69/78	70/80	63/71	153/153
			332A	18.4/24.5	51.1/58.9	76/86	80/90	69/78	151/151	78/88	80/90	72/81	153/153
		HIGH	NONE	—	—	35	50	35	154	37	50	37	156
			324A	4.9/6.5	13.6/15.6	35/35	50/50	35/35	154/154	37/37	50/50	37/37	156/156
			326A	7.9/10.5	21.9/25.3	42/46	50/50	38/42	154/154	44/48	50/50	40/44	156/156
			328A	12.0/16.0	33.4/38.5	56/63	60/70	51/57	154/154	59/65	60/70	53/59	156/156
			331A	15.8/21.0	43.8/50.5	69/78	70/80	63/71	154/154	72/80	80/80	65/73	156/156
			332A	18.4/24.5	51.1/58.9	78/88	80/90	72/81	154/154	81/90	90/100	74/83	156/156
	460-3-60	STD	NONE	—	—	16	20	15	73	17	20	16	74
			333A	6.0	7.2	16	20	15	73	17	20	16	74
			335A	11.5	13.8	23	25	20	73	24	25	22	74
			336A	14.0	16.8	26	30	24	73	28	30	25	74
			337A	21.5	25.9	38	40	34	73	39	40	36	74
			338A	24.0	28.9	42	45	38	73	43	45	39	74
		MED	NONE	—	—	16	20	16	73	17	25	17	74
			333A	6.0	7.2	16	20	16	73	17	25	17	74
			335A	11.5	13.8	23	25	21	73	24	25	22	74
			336A	14.0	16.8	27	30	24	73	28	30	26	74
			337A	21.5	25.9	38	40	35	73	40	40	36	74
			338A	24.0	28.9	42	45	38	73	43	45	39	74
		HIGH	NONE	—	—	17	20	16	74	18	25	18	75
			333A	6.0	7.2	17	20	16	74	18	25	18	75
			335A	11.5	13.8	24	25	22	74	25	25	23	75
			336A	14.0	16.8	28	30	25	74	29	30	26	75
			337A	21.5	25.9	39	40	36	74	40	45	37	75
			338A	24.0	28.9	43	45	39	74	44	45	40	75
575-3-60	STD	NONE	—	—	12	15	12	61	14	20	14	63	
		340A	15.0	14.4	23	25	20	61	25	25	23	63	
		341A	25.0	24.1	35	35	32	61	37	40	34	63	
	MED	NONE	—	—	12	15	12	61	14	20	14	63	
		340A	15.0	14.4	23	25	20	61	25	25	23	63	
		341A	25.0	24.1	35	35	32	61	37	40	34	63	
	HIGH	NONE	—	—	13	15	13	63	15	20	15	65	
		340A	15.0	14.4	24	25	21	63	26	30	24	65	
		341A	25.0	24.1	36	40	33	63	38	40	35	65	

# Electrical data (cont)

## RAV036 ELECTRIC HEAT DATA — WITHOUT NON-FUSED DISCONNECT

RAV UNIT SIZE	NOM. V-Ph-Hz	IFM TYPE	ELECTRIC HEATER PART NUMBER	NOM (kW)	APPLICATION (kW)	APPLICATION OUTPUT (MBH)	SINGLE POINT OR JUNCTION PART NUMBER CRSINGLEXXXA00			
							NO C.O. OR UNPOWERED C.O.		w/PWRD C.O.	
							NO P.E.	w/P.E. (pwrd fr/unit)	NO P.E.	w/P.E. (pwrd fr/unit)
036	208/230-1-60	STD	CRHEATER323A00	4.4	3.3/4.0	11.3/13.8	—	—	—	—
			CRHEATER324A00	6.5	4.9/6.0	16.7/20.4	—	—	—	—
			CRHEATER325A00	8.7	6.5/8.0	22.3/27.3	—	037	—	—
			CRHEATER326A00	10.5	7.9/9.6	26.9/32.9	037	040	—	—
			CRHEATER327A00	13.0	9.8/11.9	33.3/40.7	040	040	—	—
		MED	CRHEATER323A00	4.4	3.3/4.0	11.3/13.8	—	—	—	—
			CRHEATER324A00	6.5	4.9/6.0	16.7/20.4	—	—	—	—
			CRHEATER325A00	8.7	6.5/8.0	22.3/27.3	037	037	—	—
			CRHEATER326A00	10.5	7.9/9.6	26.9/32.9	040	040	—	—
		HIGH	CRHEATER327A00	13.0	9.8/11.9	33.3/40.7	040	040	—	—
			CRHEATER323A00	4.4	3.3/4.0	11.3/13.8	—	—	—	—
			CRHEATER324A00	6.5	4.9/6.0	16.7/20.4	—	—	—	—
	CRHEATER325A00		8.7	6.5/8.0	22.3/27.3	037	037	—	—	
	CRHEATER326A00		10.5	7.9/9.6	26.9/32.9	040	040	—	—	
	208/230-3-60	STD	CRHEATER323A00	4.4	3.3/4.0	11.3/13.8	—	—	—	—
			CRHEATER324A00	6.5	4.9/6.0	16.7/20.4	—	—	—	—
			CRHEATER325A00	8.7	6.5/8.0	22.3/27.3	—	—	—	—
			CRHEATER326A00	10.5	7.9/9.6	26.9/32.9	—	—	—	—
			CRHEATER328A00	16.0	12.0/14.7	41.0/50.1	037	037	037	038
		MED	CRHEATER323A00	4.4	3.3/4.0	11.3/13.8	—	—	—	—
			CRHEATER324A00	6.5	4.9/6.0	16.7/20.4	—	—	—	—
			CRHEATER325A00	8.7	6.5/8.0	22.3/27.3	—	—	—	—
			CRHEATER326A00	10.5	7.9/9.6	26.9/32.9	—	—	—	—
		HIGH	CRHEATER328A00	16.0	12.0/14.7	41.0/50.1	037	037	037	038
			CRHEATER323A00	4.4	3.3/4.0	11.3/13.8	—	—	—	—
			CRHEATER324A00	6.5	4.9/6.0	16.7/20.4	—	—	—	—
	CRHEATER325A00		8.7	6.5/8.0	22.3/27.3	—	—	—	—	
	CRHEATER326A00		10.5	7.9/9.6	26.9/32.9	—	—	—	—	
	460-3-60	STD	CRHEATER333A00	6.0	5.5	18.8	—	—	—	—
			CRHEATER334A00	8.8	8.1	27.6	—	—	—	—
			CRHEATER335A00	11.5	10.6	36.0	—	—	—	—
			CRHEATER336A00	14.0	12.9	43.9	—	—	—	—
		MED	CRHEATER333A00	6.0	5.5	18.8	—	—	—	—
			CRHEATER334A00	8.8	8.1	27.6	—	—	—	—
			CRHEATER335A00	11.5	10.6	36.0	—	—	—	—
			CRHEATER336A00	14.0	12.9	43.9	—	—	—	—
HIGH		CRHEATER333A00	6.0	5.5	18.8	—	—	—	—	
		CRHEATER334A00	8.8	8.1	27.6	—	—	—	—	
		CRHEATER335A00	11.5	10.6	36.0	—	—	—	—	
		CRHEATER336A00	14.0	12.9	43.9	—	—	—	—	
575-3-60	STD	CRHEATER339A00	10.0	9.2	31.3	—	—	—	—	
		CRHEATER340A00	15.0	13.8	47.0	—	—	—	—	
	MED	CRHEATER339A00	10.0	9.2	31.3	—	—	—	—	
		CRHEATER340A00	15.0	13.8	47.0	—	—	—	—	
	HIGH	CRHEATER339A00	10.0	9.2	31.3	—	—	—	—	
		CRHEATER340A00	15.0	13.8	47.0	—	—	—	—	

RAV036 ELECTRIC HEAT DATA — WITH NON-FUSED DISCONNECT

RAV UNIT SIZE	NOM. V-Ph-Hz	IFM TYPE	ELECTRIC HEATER PART NUMBER	NOM (kW)	APPLICATION (kW)	APPLICATION OUTPUT (MBH)	SINGLE POINT OR JUNCTION PART NUMBER CRSINGLEXXXXA00			
							NO C.O. OR UNPOWERED C.O.		w/PWRD C.O.	
							NO P.E.	w/P.E. (pwrd fr/unit)	NO P.E.	w/P.E. (pwrd fr/unit)
036	208/230-1-60	STD	CRHEATER323A00	4.4	3.3/4.0	11.3/13.8	037	037	—	—
			CRHEATER324A00	6.5	4.9/6.0	16.7/20.4	037	037	—	—
			CRHEATER325A00	8.7	6.5/8.0	22.3/27.3	037	037	—	—
			CRHEATER326A00	10.5	7.9/9.6	26.9/32.9	037	040	—	—
			CRHEATER327A00	13.0	9.8/11.9	33.3/40.7	040	040	—	—
		MED	CRHEATER323A00	4.4	3.3/4.0	11.3/13.8	037	037	—	—
			CRHEATER324A00	6.5	4.9/6.0	16.7/20.4	037	037	—	—
			CRHEATER325A00	8.7	6.5/8.0	22.3/27.3	037	037	—	—
			CRHEATER326A00	10.5	7.9/9.6	26.9/32.9	040	040	—	—
		HIGH	CRHEATER327A00	13.0	9.8/11.9	33.3/40.7	040	040	—	—
			CRHEATER323A00	4.4	3.3/4.0	11.3/13.8	037	037	—	—
			CRHEATER324A00	6.5	4.9/6.0	16.7/20.4	037	037	—	—
	CRHEATER325A00		8.7	6.5/8.0	22.3/27.3	037	037	—	—	
	CRHEATER326A00		10.5	7.9/9.6	26.9/32.9	040	040	—	—	
	208/230-3-60	STD	CRHEATER327A00	13.0	9.8/11.9	33.3/40.7	040	040	—	—
			CRHEATER323A00	4.4	3.3/4.0	11.3/13.8	037	037	037	037
			CRHEATER324A00	6.5	4.9/6.0	16.7/20.4	037	037	037	037
			CRHEATER325A00	8.7	6.5/8.0	22.3/27.3	037	037	037	037
			CRHEATER326A00	10.5	7.9/9.6	26.9/32.9	037	037	037	037
		MED	CRHEATER328A00	16.0	12.0/14.7	41.0/50.1	037	037	037	038
			CRHEATER323A00	4.4	3.3/4.0	11.3/13.8	037	037	037	037
			CRHEATER324A00	6.5	4.9/6.0	16.7/20.4	037	037	037	037
			CRHEATER325A00	8.7	6.5/8.0	22.3/27.3	037	037	037	037
		HIGH	CRHEATER326A00	10.5	7.9/9.6	26.9/32.9	037	037	037	037
			CRHEATER328A00	16.0	12.0/14.7	41.0/50.1	037	037	037	038
			CRHEATER323A00	4.4	3.3/4.0	11.3/13.8	037	037	037	037
	CRHEATER324A00		6.5	4.9/6.0	16.7/20.4	037	037	037	037	
	CRHEATER325A00		8.7	6.5/8.0	22.3/27.3	037	037	037	037	
	460-3-60	STD	CRHEATER326A00	10.5	7.9/9.6	26.9/32.9	037	037	037	037
			CRHEATER328A00	16.0	12.0/14.7	41.0/50.1	037	037	038	038
			CRHEATER333A00	6.0	5.5	18.8	—	—	—	—
			CRHEATER334A00	8.8	8.1	27.6	—	—	—	—
		MED	CRHEATER335A00	11.5	10.6	36.0	—	—	—	—
			CRHEATER336A00	14.0	12.9	43.9	—	—	—	—
			CRHEATER333A00	6.0	5.5	18.8	—	—	—	—
			CRHEATER334A00	8.8	8.1	27.6	—	—	—	—
HIGH		CRHEATER335A00	11.5	10.6	36.0	—	—	—	—	
		CRHEATER336A00	14.0	12.9	43.9	—	—	—	—	
		CRHEATER333A00	6.0	5.5	18.8	—	—	—	—	
		CRHEATER334A00	8.8	8.1	27.6	—	—	—	—	
575-3-60	STD	CRHEATER335A00	11.5	10.6	36.0	—	—	—	—	
		CRHEATER336A00	14.0	12.9	43.9	—	—	—	—	
	MED	CRHEATER339A00	10.0	9.2	31.3	—	—	—	—	
		CRHEATER340A00	15.0	13.8	47.0	—	—	—	—	
	HIGH	CRHEATER339A00	10.0	9.2	31.3	—	—	—	—	
		CRHEATER340A00	15.0	13.8	47.0	—	—	—	—	

# Electrical data (cont)

## RAV048 ELECTRIC HEAT DATA — WITHOUT NON-FUSED DISCONNECT

RAV UNIT SIZE	NOM. V-Ph-Hz	IFM TYPE	ELECTRIC HEATER PART NUMBER	NOM (kW)	APPLICATION (kW)	APPLICATION OUTPUT (MBH)	SINGLE POINT OR JUNCTION PART NUMBER CRSINGLEX000			
							NO C.O. OR UNPOWERED C.O.		w/PWRD C.O.	
							NO P.E.	w/P.E. (pwrd fr/unit)	NO P.E.	w/P.E. (pwrd fr/unit)
048	208/230-1-60	STD	CRHEATER323A00	4.4	3.3/4.0	11.3/13.8	—	—	—	—
			CRHEATER325A00	8.7	6.5/8.0	22.3/27.3	037	037	—	—
			CRHEATER327A00	13.0	9.8/11.9	33.3/40.7	040	040	—	—
			CRHEATER329A00	17.4	13.1/16.0	44.6/54.5	040	040	—	—
			CRHEATER330A00	19.2	14.4/17.6	49.2/60.2	040	040	—	—
			CRHEATER331A00	21.0	15.8/19.3	53.8/65.8	040	040	—	—
		MED	CRHEATER323A00	4.4	3.3/4.0	11.3/13.8	—	—	—	—
			CRHEATER325A00	8.7	6.5/8.0	22.3/27.3	037	037	—	—
			CRHEATER327A00	13.0	9.8/11.9	33.3/40.7	040	040	—	—
			CRHEATER329A00	17.4	13.1/16.0	44.6/54.5	040	040	—	—
			CRHEATER330A00	19.2	14.4/17.6	49.2/60.2	040	040	—	—
			CRHEATER331A00	21.0	15.8/19.3	53.8/65.8	040	040	—	—
	HIGH	CRHEATER323A00	4.4	3.3/4.0	11.3/13.8	—	—	—	—	
		CRHEATER325A00	8.7	6.5/8.0	22.3/27.3	037	037	—	—	
		CRHEATER327A00	13.0	9.8/11.9	33.3/40.7	040	040	—	—	
		CRHEATER329A00	17.4	13.1/16.0	44.6/54.5	040	040	—	—	
		CRHEATER330A00	19.2	14.4/17.6	49.2/60.2	040	040	—	—	
		CRHEATER331A00	21.0	15.8/19.3	53.8/65.8	040	040	—	—	
	208/230-3-60	STD	CRHEATER324A00	6.5	4.9/6.0	16.7/20.4	—	—	—	—
			CRHEATER325A00	8.7	6.5/8.0	22.3/27.3	—	—	—	—
			CRHEATER328A00	16.0	12.0/14.7	41.0/50.1	037	037	037	038
			CRHEATER330A00	19.2	14.4/17.6	49.2/60.2	038	038	038	038
			CRHEATER331A00	21.0	15.8/19.3	53.8/65.8	038	038	038	038
		MED	CRHEATER324A00	6.5	4.9/6.0	16.7/20.4	—	—	—	—
CRHEATER325A00			8.7	6.5/8.0	22.3/27.3	—	—	—	—	
CRHEATER328A00			16.0	12.0/14.7	41.0/50.1	037	037	038	038	
CRHEATER330A00			19.2	14.4/17.6	49.2/60.2	038	038	038	038	
HIGH		CRHEATER331A00	21.0	15.8/19.3	53.8/65.8	038	038	038	038	
		CRHEATER324A00	6.5	4.9/6.0	16.7/20.4	—	—	—	—	
		CRHEATER325A00	8.7	6.5/8.0	22.3/27.3	—	—	—	—	
	CRHEATER328A00	16.0	12.0/14.7	41.0/50.1	037	037	038	038		
460-3-60	STD	CRHEATER333A00	6.0	5.5	18.8	—	—	—	—	
		CRHEATER335A00	11.5	10.6	36.0	—	—	—	—	
		CRHEATER336A00	14.0	12.9	43.9	—	—	—	—	
		CRHEATER337A00	21.5	19.7	67.4	037	037	037	037	
	MED	CRHEATER333A00	6.0	5.5	18.8	—	—	—	—	
		CRHEATER335A00	11.5	10.6	36.0	—	—	—	—	
		CRHEATER336A00	14.0	12.9	43.9	—	—	—	—	
		CRHEATER337A00	21.5	19.7	67.4	037	037	037	037	
	HIGH	CRHEATER333A00	6.0	5.5	18.8	—	—	—	—	
		CRHEATER335A00	11.5	10.6	36.0	—	—	—	—	
		CRHEATER336A00	14.0	12.9	43.9	—	—	—	—	
		CRHEATER337A00	21.5	19.7	67.4	037	037	037	037	
575-3-60	STD	CRHEATER339A00	10.0	9.2	31.3	—	—	—	—	
		CRHEATER340A00	15.0	13.8	47.0	—	—	—	—	
	MED	CRHEATER339A00	10.0	9.2	31.3	—	—	—	—	
		CRHEATER340A00	15.0	13.8	47.0	—	—	—	—	
	HIGH	CRHEATER339A00	10.0	9.2	31.3	—	—	—	—	
		CRHEATER340A00	15.0	13.8	47.0	—	—	—	—	

**RAV048 ELECTRIC HEAT DATA — WITH NON-FUSED DISCONNECT**

RAV UNIT SIZE	NOM. V-Ph-Hz	IFM TYPE	ELECTRIC HEATER PART NUMBER	NOM (kW)	APPLICATION (kW)	APPLICATION OUTPUT (MBH)	SINGLE POINT OR JUNCTION PART NUMBER CRSINGLEXXXA00			
							NO C.O. OR UNPOWERED C.O.		w/PWRD C.O.	
							NO P.E.	w/P.E. (pwrd fr/unit)	NO P.E.	w/P.E. (pwrd fr/unit)
048	208/230-1-60	STD	CRHEATER323A00	4.4	3.3/4.0	11.3/13.8	037	037	—	—
			CRHEATER325A00	8.7	6.5/8.0	22.3/27.3	037	037	—	—
			CRHEATER327A00	13.0	9.8/11.9	33.3/40.7	040	040	—	—
			CRHEATER329A00	17.4	13.1/16.0	44.6/54.5	040	040	—	—
			CRHEATER330A00	19.2	14.4/17.6	49.2/60.2	040	040	—	—
			CRHEATER331A00	21.0	15.8/19.3	53.8/65.8	040	040	—	—
		MED	CRHEATER323A00	4.4	3.3/4.0	11.3/13.8	037	037	—	—
			CRHEATER325A00	8.7	6.5/8.0	22.3/27.3	037	037	—	—
			CRHEATER327A00	13.0	9.8/11.9	33.3/40.7	040	040	—	—
			CRHEATER329A00	17.4	13.1/16.0	44.6/54.5	040	040	—	—
			CRHEATER330A00	19.2	14.4/17.6	49.2/60.2	040	040	—	—
			CRHEATER331A00	21.0	15.8/19.3	53.8/65.8	040	040	—	—
		HIGH	CRHEATER323A00	4.4	3.3/4.0	11.3/13.8	037	037	—	—
			CRHEATER325A00	8.7	6.5/8.0	22.3/27.3	037	037	—	—
			CRHEATER327A00	13.0	9.8/11.9	33.3/40.7	040	040	—	—
			CRHEATER329A00	17.4	13.1/16.0	44.6/54.5	040	040	—	—
			CRHEATER330A00	19.2	14.4/17.6	49.2/60.2	040	040	—	—
			CRHEATER331A00	21.0	15.8/19.3	53.8/65.8	040	040	—	—
	208/230-3-60	STD	CRHEATER324A00	6.5	4.9/6.0	16.7/20.4	037	037	037	037
			CRHEATER325A00	8.7	6.5/8.0	22.3/27.3	037	037	037	037
			CRHEATER328A00	16.0	12.0/14.7	41.0/50.1	037	037	037	038
			CRHEATER330A00	19.2	14.4/17.6	49.2/60.2	038	038	038	038
			CRHEATER331A00	21.0	15.8/19.3	53.8/65.8	038	038	038	038
			CRHEATER337A00	21.5	19.7	67.4	037	037	037	037
		MED	CRHEATER324A00	6.5	4.9/6.0	16.7/20.4	037	037	037	037
			CRHEATER325A00	8.7	6.5/8.0	22.3/27.3	037	037	037	037
			CRHEATER328A00	16.0	12.0/14.7	41.0/50.1	037	037	038	038
			CRHEATER330A00	19.2	14.4/17.6	49.2/60.2	038	038	038	038
			CRHEATER331A00	21.0	15.8/19.3	53.8/65.8	038	038	038	038
			CRHEATER337A00	21.5	19.7	67.4	037	037	037	037
		HIGH	CRHEATER324A00	6.5	4.9/6.0	16.7/20.4	037	037	037	037
			CRHEATER325A00	8.7	6.5/8.0	22.3/27.3	037	037	037	037
			CRHEATER328A00	16.0	12.0/14.7	41.0/50.1	037	037	038	038
			CRHEATER330A00	19.2	14.4/17.6	49.2/60.2	038	038	038	038
			CRHEATER331A00	21.0	15.8/19.3	53.8/65.8	038	038	038	038
			CRHEATER337A00	21.5	19.7	67.4	037	037	037	037
460-3-60	STD	CRHEATER333A00	6.0	5.5	18.8	—	—	—	—	
		CRHEATER335A00	11.5	10.6	36.0	—	—	—	—	
		CRHEATER336A00	14.0	12.9	43.9	—	—	—	—	
		CRHEATER337A00	21.5	19.7	67.4	037	037	037	037	
	MED	CRHEATER333A00	6.0	5.5	18.8	—	—	—	—	
		CRHEATER335A00	11.5	10.6	36.0	—	—	—	—	
		CRHEATER336A00	14.0	12.9	43.9	—	—	—	—	
		CRHEATER337A00	21.5	19.7	67.4	037	037	037	037	
	HIGH	CRHEATER333A00	6.0	5.5	18.8	—	—	—	—	
		CRHEATER335A00	11.5	10.6	36.0	—	—	—	—	
		CRHEATER336A00	14.0	12.9	43.9	—	—	—	—	
		CRHEATER337A00	21.5	19.7	67.4	037	037	037	037	
575-3-60	STD	CRHEATER339A00	10.0	9.2	31.3	—	—	—	—	
		CRHEATER340A00	15.0	13.8	47.0	—	—	—	—	
	MED	CRHEATER339A00	10.0	9.2	31.3	—	—	—	—	
		CRHEATER340A00	15.0	13.8	47.0	—	—	—	—	
	HIGH	CRHEATER339A00	10.0	9.2	31.3	—	—	—	—	
		CRHEATER340A00	15.0	13.8	47.0	—	—	—	—	

# Electrical data (cont)

## RAV060 ELECTRIC HEAT DATA — WITHOUT NON-FUSED DISCONNECT

RAV UNIT SIZE	NOM. V-Ph-Hz	IFM TYPE	ELECTRIC HEATER PART NUMBER	NOM (kW)	APPLICATION (kW)	APPLICATION OUTPUT (MBH)	SINGLE POINT OR JUNCTION PART NUMBER CRSINGLEXXXA00				
							NO C.O. OR UNPOWERED C.O.		w/PWRD C.O.		
							NO P.E.	w/P.E. (pwrd fr/unit)	NO P.E.	w/P.E. (pwrd fr/unit)	
060	208/230-1-60	STD	CRHEATER324A00	6.5	4.9/6.0	16.7/20.4	—	—	—	—	
			CRHEATER325A00	8.7	6.5/8.0	22.3/27.3	037	037	—	—	
			CRHEATER327A00	13.0	9.8/11.9	33.3/40.7	040	040	—	—	
			CRHEATER329A00	17.4	13.1/16.0	44.6/54.5	040	040	—	—	
			CRHEATER331A00	21.0	15.8/19.3	53.8/65.8	040	040	—	—	
		MED	CRHEATER324A00	6.5	4.9/6.0	16.7/20.4	—	—	—	—	
			CRHEATER325A00	8.7	6.5/8.0	22.3/27.3	037	037	—	—	
			CRHEATER327A00	13.0	9.8/11.9	33.3/40.7	040	040	—	—	
			CRHEATER329A00	17.4	13.1/16.0	44.6/54.5	040	040	—	—	
			CRHEATER331A00	21.0	15.8/19.3	53.8/65.8	040	040	—	—	
		208/230-3-60	STD	CRHEATER324A00	6.5	4.9/6.0	16.7/20.4	—	—	—	—
				CRHEATER326A00	10.5	7.9/9.6	26.9/32.9	—	—	—	—
	CRHEATER328A00			16.0	12.0/14.7	41.0/50.1	037	037	038	038	
	CRHEATER331A00			21.0	15.8/19.3	53.8/65.8	038	038	038	038	
	CRHEATER332A00			24.5	18.4/22.5	62.8/76.8	038	038	038	038	
	MED		CRHEATER324A00	6.5	4.9/6.0	16.7/20.4	—	—	—	—	
			CRHEATER326A00	10.5	7.9/9.6	26.9/32.9	—	—	—	037	
			CRHEATER328A00	16.0	12.0/14.7	41.0/50.1	037	038	038	038	
			CRHEATER331A00	21.0	15.8/19.3	53.8/65.8	038	038	038	038	
			CRHEATER332A00	24.5	18.4/22.5	62.8/76.8	038	038	038	038	
	HIGH		CRHEATER324A00	6.5	4.9/6.0	16.7/20.4	—	—	—	—	
			CRHEATER326A00	10.5	7.9/9.6	26.9/32.9	—	—	—	—	
		CRHEATER328A00	16.0	12.0/14.7	41.0/50.1	037	037	038	038		
		CRHEATER331A00	21.0	15.8/19.3	53.8/65.8	038	038	038	038		
		CRHEATER332A00	24.5	18.4/22.5	62.8/76.8	038	038	038	038		
	460-3-60	STD	CRHEATER333A00	6.0	5.5	18.8	—	—	—	—	
			CRHEATER335A00	11.5	10.6	36.0	—	—	—	—	
			CRHEATER336A00	14.0	12.9	43.9	—	—	—	—	
			CRHEATER337A00	21.5	19.7	67.4	037	037	037	037	
			CRHEATER338A00	24.0	22.0	75.2	037	037	037	037	
		MED	CRHEATER333A00	6.0	5.5	18.8	—	—	—	—	
			CRHEATER335A00	11.5	10.6	36.0	—	—	—	—	
			CRHEATER336A00	14.0	12.9	43.9	—	—	—	—	
			CRHEATER337A00	21.5	19.7	67.4	037	037	037	037	
			CRHEATER338A00	24.0	22.0	75.2	037	037	037	037	
		HIGH	CRHEATER333A00	6.0	5.5	18.8	—	—	—	—	
			CRHEATER335A00	11.5	10.6	36.0	—	—	—	—	
			CRHEATER336A00	14.0	12.9	43.9	—	—	—	—	
			CRHEATER337A00	21.5	19.7	67.4	037	037	037	037	
			CRHEATER338A00	24.0	22.0	75.2	037	037	037	037	
575-3-60	STD	CRHEATER340A00	15.0	13.8	47.0	—	—	—	—		
		CRHEATER341A00	25.0	23.0	78.3	037	037	037	037		
	MED	CRHEATER340A00	15.0	13.8	47.0	—	—	—	—		
		CRHEATER341A00	25.0	23.0	78.3	037	037	037	037		
	HIGH	CRHEATER340A00	15.0	13.8	47.0	—	—	—	—		
CRHEATER341A00		25.0	23.0	78.3	037	037	037	037			

RAV060 ELECTRIC HEAT DATA — WITH NON-FUSED DISCONNECT

RAV UNIT SIZE	NOM. V-Ph-Hz	IFM TYPE	ELECTRIC HEATER PART NUMBER	NOM (kW)	APPLICATION (kW)	APPLICATION OUTPUT (MBH)	SINGLE POINT OR JUNCTION PART NUMBER CRSINGLEXXXA00			
							NO C.O. OR UNPOWERED C.O.		w/PWRD C.O.	
							NO P.E.	w/P.E. (pwrdr fr/unit)	NO P.E.	w/P.E. (pwrdr fr/unit)
060	208/230-1-60	STD	CRHEATER324A00	6.5	4.9/6.0	16.7/20.4	037	037	—	—
			CRHEATER325A00	8.7	6.5/8.0	22.3/27.3	037	037	—	—
			CRHEATER327A00	13.0	9.8/11.9	33.3/40.7	040	040	—	—
			CRHEATER329A00	17.4	13.1/16.0	44.6/54.5	040	040	—	—
			CRHEATER331A00	21.0	15.8/19.3	53.8/65.8	040	040	—	—
		MED	CRHEATER324A00	6.5	4.9/6.0	16.7/20.4	037	037	—	—
			CRHEATER325A00	8.7	6.5/8.0	22.3/27.3	037	037	—	—
			CRHEATER327A00	13.0	9.8/11.9	33.3/40.7	040	040	—	—
			CRHEATER329A00	17.4	13.1/16.0	44.6/54.5	040	040	—	—
			CRHEATER331A00	21.0	15.8/19.3	53.8/65.8	040	040	—	—
	208/230-3-60	STD	CRHEATER324A00	6.5	4.9/6.0	16.7/20.4	037	037	037	037
			CRHEATER326A00	10.5	7.9/9.6	26.9/32.9	037	037	037	037
			CRHEATER328A00	16.0	12.0/14.7	41.0/50.1	037	037	038	038
			CRHEATER331A00	21.0	15.8/19.3	53.8/65.8	038	038	038	038
			CRHEATER332A00	24.5	18.4/22.5	62.8/76.8	038	038	038	038
		MED	CRHEATER324A00	6.5	4.9/6.0	16.7/20.4	037	037	037	037
			CRHEATER326A00	10.5	7.9/9.6	26.9/32.9	037	037	037	037
			CRHEATER328A00	16.0	12.0/14.7	41.0/50.1	037	038	038	038
			CRHEATER331A00	21.0	15.8/19.3	53.8/65.8	038	038	038	038
			CRHEATER332A00	24.5	18.4/22.5	62.8/76.8	038	038	038	038
		HIGH	CRHEATER324A00	6.5	4.9/6.0	16.7/20.4	037	037	037	037
			CRHEATER326A00	10.5	7.9/9.6	26.9/32.9	037	037	037	037
			CRHEATER328A00	16.0	12.0/14.7	41.0/50.1	037	037	038	038
			CRHEATER331A00	21.0	15.8/19.3	53.8/65.8	038	038	038	038
	460-3-60	STD	CRHEATER333A00	6.0	5.5	18.8	—	—	—	—
			CRHEATER335A00	11.5	10.6	36.0	—	—	—	—
			CRHEATER336A00	14.0	12.9	43.9	—	—	—	—
			CRHEATER337A00	21.5	19.7	67.4	037	037	037	037
			CRHEATER338A00	24.0	22.0	75.2	037	037	037	037
		MED	CRHEATER333A00	6.0	5.5	18.8	—	—	—	—
			CRHEATER335A00	11.5	10.6	36.0	—	—	—	—
			CRHEATER336A00	14.0	12.9	43.9	—	—	—	—
			CRHEATER337A00	21.5	19.7	67.4	037	037	037	037
			CRHEATER338A00	24.0	22.0	75.2	037	037	037	037
		HIGH	CRHEATER333A00	6.0	5.5	18.8	—	—	—	—
			CRHEATER335A00	11.5	10.6	36.0	—	—	—	—
			CRHEATER336A00	14.0	12.9	43.9	—	—	—	—
			CRHEATER337A00	21.5	19.7	67.4	037	037	037	037
			CRHEATER338A00	24.0	22.0	75.2	037	037	037	037
	575-3-60	STD	CRHEATER340A00	15.0	13.8	47.0	—	—	—	—
CRHEATER341A00			25.0	23.0	78.3	037	037	037	037	
MED		CRHEATER340A00	15.0	13.8	47.0	—	—	—	—	
		CRHEATER341A00	25.0	23.0	78.3	037	037	037	037	
HIGH		CRHEATER340A00	15.0	13.8	47.0	—	—	—	—	
		CRHEATER341A00	25.0	23.0	78.3	037	037	037	037	

# Electrical data (cont)

## RAV072 ELECTRIC HEAT DATA — WITHOUT NON-FUSED DISCONNECT

RAV UNIT SIZE	NOM. V-Ph-Hz	IFM TYPE	ELECTRIC HEATER PART NUMBER	NOM (kW)	APPLICATION (kW)	APPLICATION OUTPUT (MBH)	SINGLE POINT OR JUNCTION PART NUMBER CRSINGLEXXXA00			
							NO C.O. OR UNPOWERED C.O.		w/PWRD C.O.	
							NO P.E.	w/P.E. (pwrd fr/unit)	NO P.E.	w/P.E. (pwrd fr/unit)
072	208/230-3-60	STD	CRHEATER324A00	6.5	4.9/6.0	16.7/20.4	—	—	—	—
			CRHEATER326A00	10.5	7.9/9.6	26.9/32.9	—	—	—	—
			CRHEATER328A00	16.0	12.0/14.7	41.0/50.1	037	038	038	038
			CRHEATER331A00	21.0	15.8/19.3	53.8/65.8	038	038	038	038
			CRHEATER332A00	24.5	18.4/22.5	62.8/76.8	038	038	038	038
		MED	CRHEATER324A00	6.5	4.9/6.0	16.7/20.4	—	—	—	—
			CRHEATER326A00	10.5	7.9/9.6	26.9/32.9	—	—	—	—
			CRHEATER328A00	16.0	12.0/14.7	41.0/50.1	037	037	037	038
			CRHEATER331A00	21.0	15.8/19.3	53.8/65.8	038	038	038	038
			CRHEATER332A00	24.5	18.4/22.5	62.8/76.8	038	038	038	038
		HIGH	CRHEATER324A00	6.5	4.9/6.0	16.7/20.4	—	—	—	—
			CRHEATER326A00	10.5	7.9/9.6	26.9/32.9	—	—	—	—
	CRHEATER328A00		16.0	12.0/14.7	41.0/50.1	037	037	038	038	
	CRHEATER331A00		21.0	15.8/19.3	53.8/65.8	038	038	038	038	
	CRHEATER332A00		24.5	18.4/22.5	62.8/76.8	038	038	038	038	
	460-3-60	STD	CRHEATER333A00	6.0	5.5	18.8	—	—	—	—
			CRHEATER335A00	11.5	10.6	36.0	—	—	—	—
			CRHEATER336A00	14.0	12.9	43.9	—	—	—	—
			CRHEATER337A00	21.5	19.7	67.4	037	037	037	037
			CRHEATER338A00	24.0	22.0	75.2	037	037	037	037
		MED	CRHEATER333A00	6.0	5.5	18.8	—	—	—	—
			CRHEATER335A00	11.5	10.6	36.0	—	—	—	—
			CRHEATER336A00	14.0	12.9	43.9	—	—	—	—
			CRHEATER337A00	21.5	19.7	67.4	037	037	037	037
CRHEATER338A00			24.0	22.0	75.2	037	037	037	037	
HIGH		CRHEATER333A00	6.0	5.5	18.8	—	—	—	—	
		CRHEATER335A00	11.5	10.6	36.0	—	—	—	—	
	CRHEATER336A00	14.0	12.9	43.9	—	—	—	—		
	CRHEATER337A00	21.5	19.7	67.4	037	037	037	037		
	CRHEATER338A00	24.0	22.0	75.2	037	037	037	037		
575-3-60	STD	CRHEATER340A00	15.0	13.8	47.0	—	—	—	—	
		CRHEATER341A00	25.0	23.0	78.3	037	037	037	037	
	MED	CRHEATER340A00	15.0	13.8	47.0	—	—	—	—	
		CRHEATER341A00	25.0	23.0	78.3	037	037	037	037	
	HIGH	CRHEATER340A00	15.0	13.8	47.0	—	—	—	—	
		CRHEATER341A00	25.0	23.0	78.3	037	037	037	037	

**RAV072 ELECTRIC HEAT DATA — WITH NON-FUSED DISCONNECT**

RAV UNIT SIZE	NOM. V-Ph-Hz	IFM TYPE	ELECTRIC HEATER PART NUMBER	NOM (kW)	APPLICATION (kW)	APPLICATION OUTPUT (MBH)	SINGLE POINT OR JUNCTION PART NUMBER CRSINGLEXXXXA00			
							NO C.O. OR UNPOWERED C.O.		w/PWRD C.O.	
							NO P.E.	w/P.E. (pwrd fr/unit)	NO P.E.	w/P.E. (pwrd fr/unit)
072	208/230-3-60	STD	CRHEATER324A00	6.5	4.9/6.0	16.7/20.4	037	037	037	037
			CRHEATER326A00	10.5	7.9/9.6	26.9/32.9	037	037	037	037
			CRHEATER328A00	16.0	12.0/14.7	41.0/50.1	037	038	038	038
			CRHEATER331A00	21.0	15.8/19.3	53.8/65.8	038	038	038	038
			CRHEATER332A00	24.5	18.4/22.5	62.8/76.8	038	038	038	038
		MED	CRHEATER324A00	6.5	4.9/6.0	16.7/20.4	037	037	037	037
			CRHEATER326A00	10.5	7.9/9.6	26.9/32.9	037	037	037	037
			CRHEATER328A00	16.0	12.0/14.7	41.0/50.1	037	037	037	038
			CRHEATER331A00	21.0	15.8/19.3	53.8/65.8	038	038	038	038
		HIGH	CRHEATER332A00	24.5	18.4/22.5	62.8/76.8	038	038	038	038
			CRHEATER324A00	6.5	4.9/6.0	16.7/20.4	037	037	037	037
			CRHEATER326A00	10.5	7.9/9.6	26.9/32.9	037	037	037	037
	460-3-60	STD	CRHEATER338A00	24.0	22.0	75.2	037	037	037	037
			CRHEATER333A00	6.0	5.5	18.8	—	—	—	—
			CRHEATER335A00	11.5	10.6	36.0	—	—	—	—
			CRHEATER336A00	14.0	12.9	43.9	—	—	—	—
			CRHEATER337A00	21.5	19.7	67.4	037	037	037	037
		MED	CRHEATER338A00	24.0	22.0	75.2	037	037	037	037
			CRHEATER333A00	6.0	5.5	18.8	—	—	—	—
			CRHEATER335A00	11.5	10.6	36.0	—	—	—	—
			CRHEATER336A00	14.0	12.9	43.9	—	—	—	—
		HIGH	CRHEATER337A00	21.5	19.7	67.4	037	037	037	037
			CRHEATER338A00	24.0	22.0	75.2	037	037	037	037
			CRHEATER333A00	6.0	5.5	18.8	—	—	—	—
575-3-60	STD	CRHEATER338A00	24.0	22.0	75.2	037	037	037	037	
		CRHEATER340A00	15.0	13.8	47.0	—	—	—	—	
	MED	CRHEATER341A00	25.0	23.0	78.3	037	037	037	037	
		CRHEATER340A00	15.0	13.8	47.0	—	—	—	—	
	HIGH	CRHEATER341A00	25.0	23.0	78.3	037	037	037	037	
		CRHEATER340A00	15.0	13.8	47.0	—	—	—	—	



# TYPICAL CONTROL WIRING DIAGRAM — RGV072 208-230/3/60 UNIT WITH ELECTRO-MECHANICAL CONTROL AND W720 ECONOMIZER

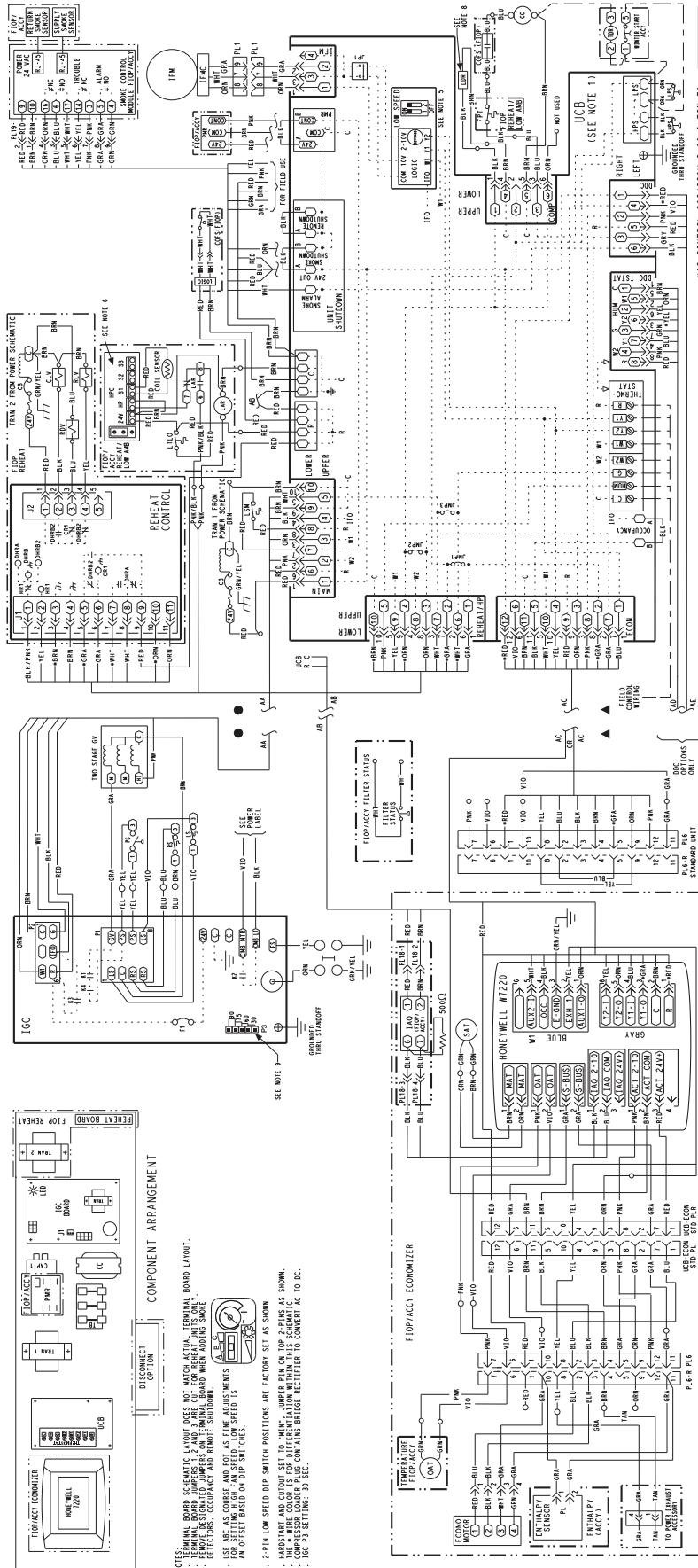

YAC CONTROL 208/230V-3-60 60 TON T1

REHEAT CONTROL

FIPACTY W720

FIPACTY ECONOMIZER

TERMINAL BLOCK

REHEAT CONTROL

FIPACTY W720

FIPACTY ECONOMIZER

# Typical wiring diagrams (cont)

**TYPICAL CONTROL WIRING DIAGRAM — RGV036-060 460-575/3/60 UNIT WITH ELECTRO-MECHANICAL CONTROL AND W7212 ECONOMIZER**

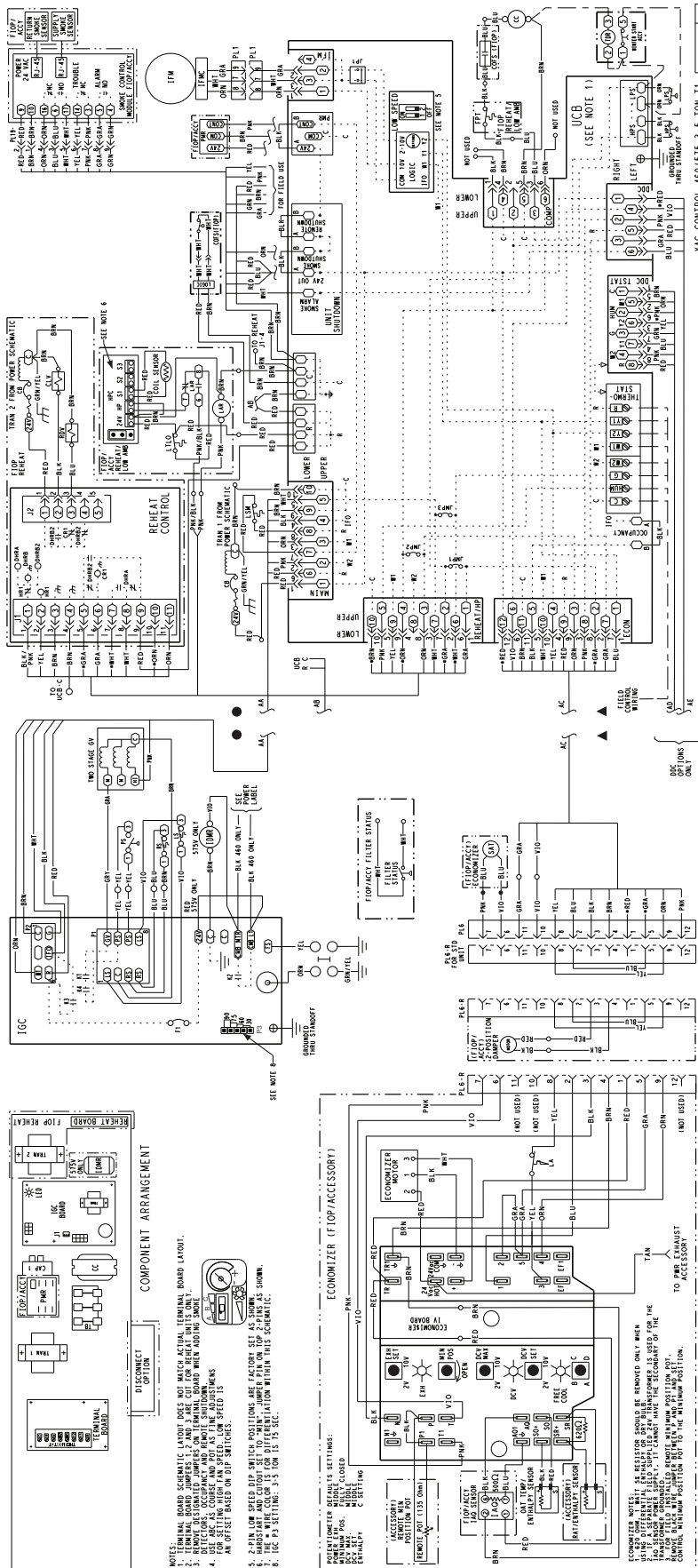

# TYPICAL CONTROL WIRING DIAGRAM — RGV072 460-575/3/60 UNIT WITH ELECTRO-MECHANICAL CONTROL AND W720 ECONOMIZER

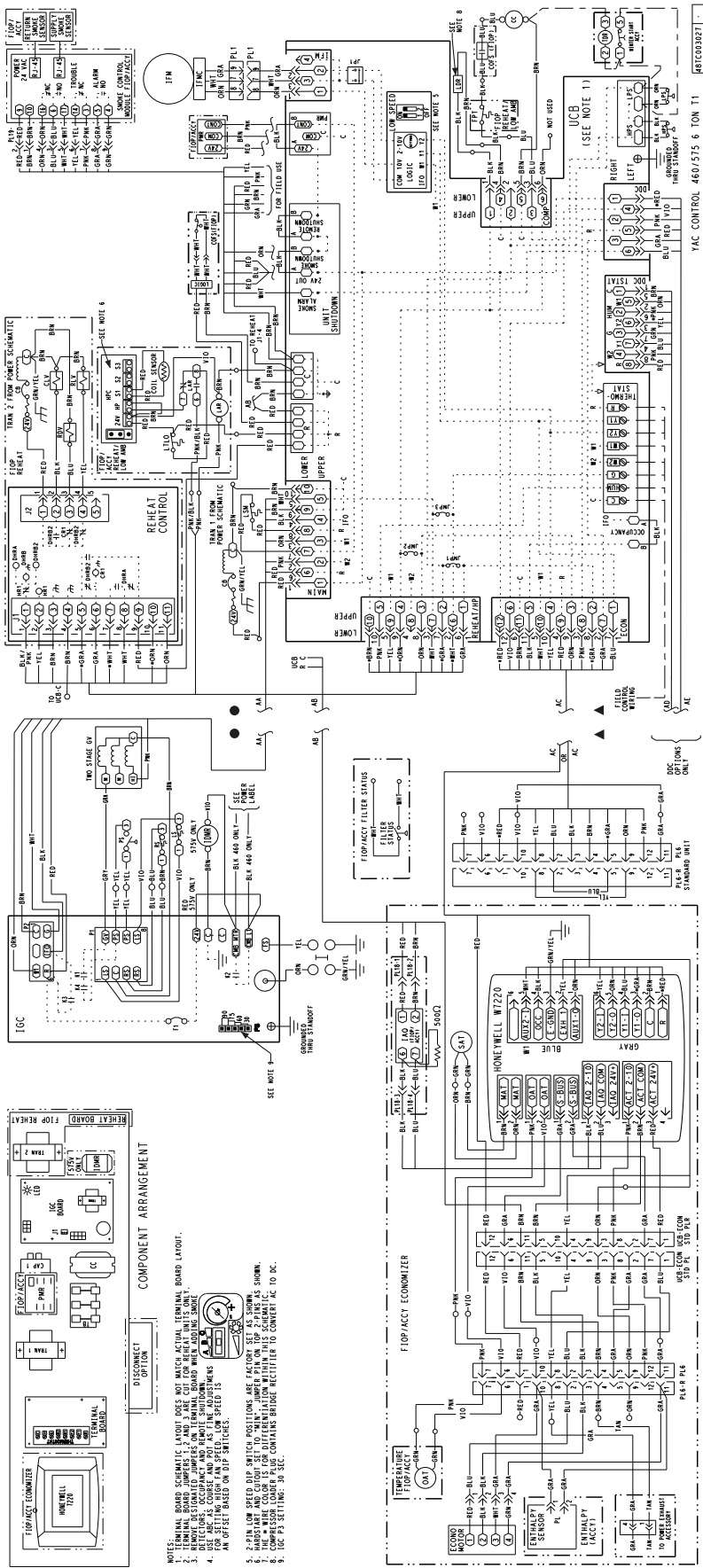

# Typical wiring diagrams (cont)

TYPICAL RGV036-072 POWER WIRING DIAGRAM, 208-230/3/60 UNIT SHOWN

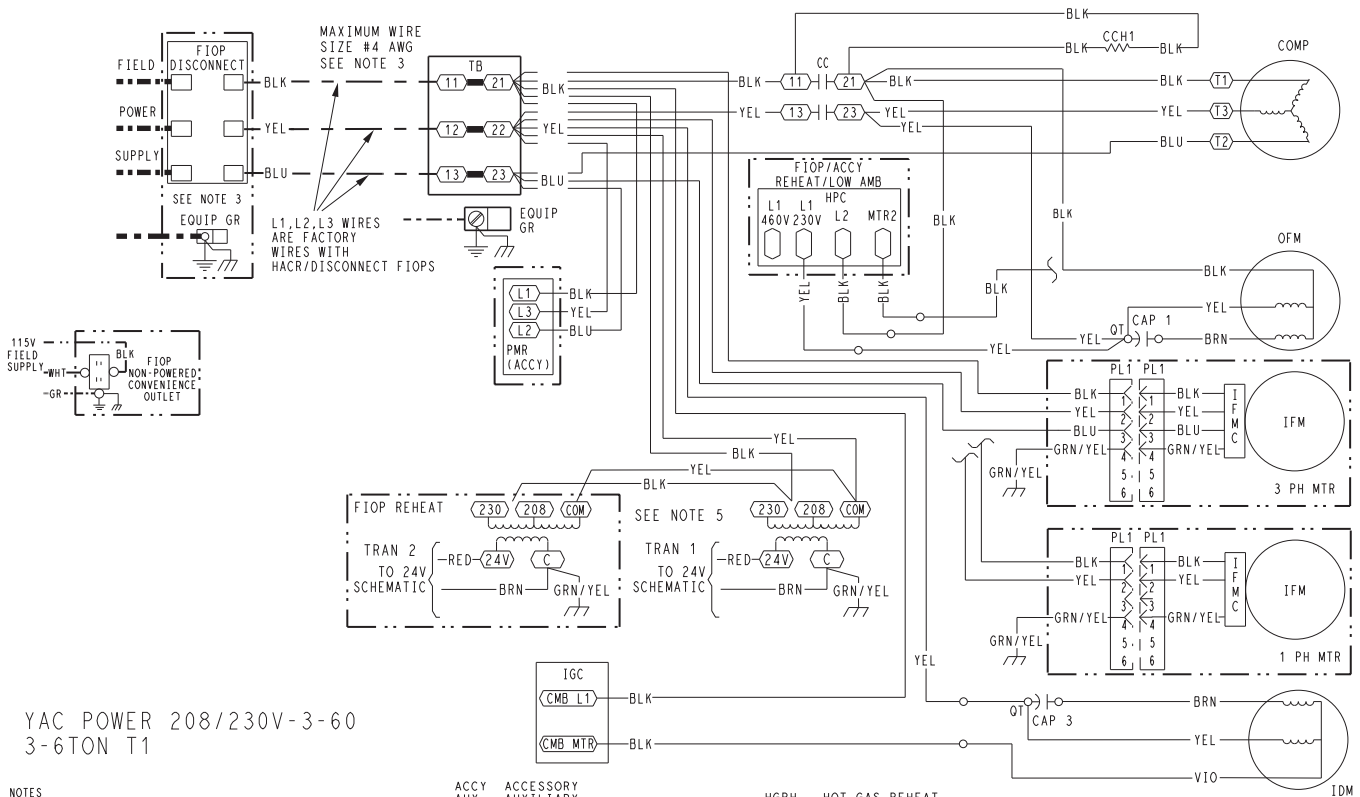

YAC POWER 208/230V-3-60  
3-6TON T1

**NOTES**

1. IF ANY OF THE ORIGINAL WIRE FURNISHED MUST BE REPLACED, IT MUST BE REPLACED WITH TYPE 90° C WIRE OR ITS EQUIVALENT.
2. COMPRESSOR AND FAN MOTORS ARE THERMALLY PROTECTED.
3. USE COPPER CONDUCTOR ONLY.
4. DO NOT DISCONNECT POWER PLUG OR SIGNAL WIRE WHILE UNDER LOAD.
5. ON 208/230V UNITS, TRAN IS WIRED FOR 230V. IF UNIT IS TO BE RUN WITH 208V POWER SUPPLY, DISCONNECT BLK WIRE FROM 230V TAP AND CONNECT TO 208V TAP.

**LEGEND**

- (X) MARKED WIRE
- (X) TERMINAL (MARKED)
- ( ) TERMINAL (UNMARKED)
- (X) TERMINAL BLOCK
- SPLICE
- SPLICE (MARKED)
- FACTORY WIRING
- FIELD CONTROL WIRING
- FIELD POWER WIRING
- CIRCUIT BOARD TRACE
- ACCESSORY OR OPTIONAL WIRING

- ACCY ACCESSORY
- AUX AUXILIARY
- AWG AMERICAN WIRE GAGE
- BA BUILDING AUTOMATION NETWORK
- CA CONTACTOR, COMPRESSOR
- C COMMON
- CAP CAPACITOR
- CB CIRCUIT BREAKER
- CCH CRANKCASE HEATER
- CCHR CRANKCASE HEATER RELAY
- CCHTS CRANKCASE HEATER TEMP SWITCH
- CLO COMPRESSOR LOCKOUT
- CLV COOLING LIQUID VALVE
- CMB CENTRIFUGAL MOTOR BLOWER
- COFS CONDENSATE OVERFLOW SWITCH
- COM SIGNAL COMMON
- COMP COMPRESSOR MOTOR
- DDC DIRECT DIGITAL CONTROL
- DFB DEFROST BOARD
- DFT DEFROST THERMOSTAT
- EHR ELECTRIC HEAT RELAY
- ENTH ENTHALPY
- EQUIP EQUIPMENT
- ERV ENERGY RECOVERY VENTILATOR
- ESL ENTHALPY SENSOR - LOW
- FB FUSE BLOCK
- FIOF FACTORY INSTALLED OPTION
- FPT FREEZE PROTECTION THERMOSTAT
- FS FLAME SWITCH
- FST FAN HOUSING TEMP SENSOR
- FU FUSE
- G THERMOSTAT FAN CALL
- GR(GND) GROUND
- GV GAS VALVE
- HACR HEATING, AIR-CONDITIONING, REFRIGERATION BREAKER

- HGRH HOT GAS REHEAT
- HPC HEAD PRESSURE CONTROL
- HPS HIGH PRESSURE SWITCH
- HR HEATER RELAY
- HUM HUMIDISTAT
- IAO INDOOR AIR QUALITY SENSORS
- IDM INDUCED DRAFT MOTOR
- IDMR INDUCED DRAFT RELAY
- IFM INDOOR FAN MOTOR
- IFMC INDOOR FAN MOTOR CONTROL
- IFO INDOOR FAN ON SIGNAL
- IGC INTEGRATED GAS CONTROL
- I IGNITOR
- IRH INDOOR RELATIVE HUMIDITY
- JMP JUMPER
- L1 LINE 1
- LA LOW AMBIENT LOCKOUT
- LAR LOW AMBIENT RELAY
- LAS LOW AMBIENT SWITCH
- LDR COMPRESSOR LOADER
- LEN LOCAL EQUIPMENT NETWORK
- LOC LOSS OF CHARGE
- LOOP PWR CURRENT LOOP POWER
- LPS LOW PRESSURE SWITCH
- LS LIMIT SWITCH
- LSM LIMIT SWITCH (MANUAL RESET)
- LTLO LOW TEMP LOCKOUT
- MBB MAIN BASE BOARD
- MOV METAL OXIDE VARISTOR
- MTR MOTOR
- OAO OUTDOOR AIR QUALITY
- OAT OUTDOOR AIR TEMP. SEN
- OFM OUTDOOR FAN MOTOR
- OFR OUTDOOR FAN RELAY
- OL OVERLOAD

- PER POWER EXHAUST RELAY
- PH PHASE
- PL PLUG ASSEMBLY
- POT POTENTIOMETER
- PMR PHASE MONITOR RELAY
- PS PRESSURE SWITCH
- PWM PULSE WIDTH MODULATION
- QT QUADRUPLE TERMINAL
- R THERMOSTAT POWER
- RAT RETURN AIR TEMP. SEN
- RDV REHEAT DISCHARGE VALVE
- RH RELATIVE HUMIDITY
- RLV REHEAT LIQUID VALVE
- RNET LOCAL ACCESS NETWORK
- RS ROLLOUT SWITCH
- RVS REVERSING VALVE SOLENOID
- SAT SUPPLY AIR TEMP SENSOR
- SDP SYSTEM DISCHARGE PRESSURE
- SPRH SPACE RELATIVE HUMIDITY
- SPT SPACE TEMPERATURE SENSOR
- SPTO SPACE TEMPERATURE OFFSET
- SSP SYSTEM SUCTION PRESSURE
- STD STANDARD
- SW SWITCH
- TB TERMINAL BLOCK
- TDR TIME DELAY RELAY
- TRAN TRANSFORMER
- UCB UNIT CONTROL BOARD
- W1 1st STAGE OF HEATING CALL
- W2 2nd STAGE OF HEATING CALL
- Y1 1st STAGE OF COOLING CALL
- Y2 2nd STAGE OF COOLING CALL

48TC002991 -

**TYPICAL RG036-072 POWER WIRING DIAGRAM, 460-575/3/60 UNIT SHOWN**

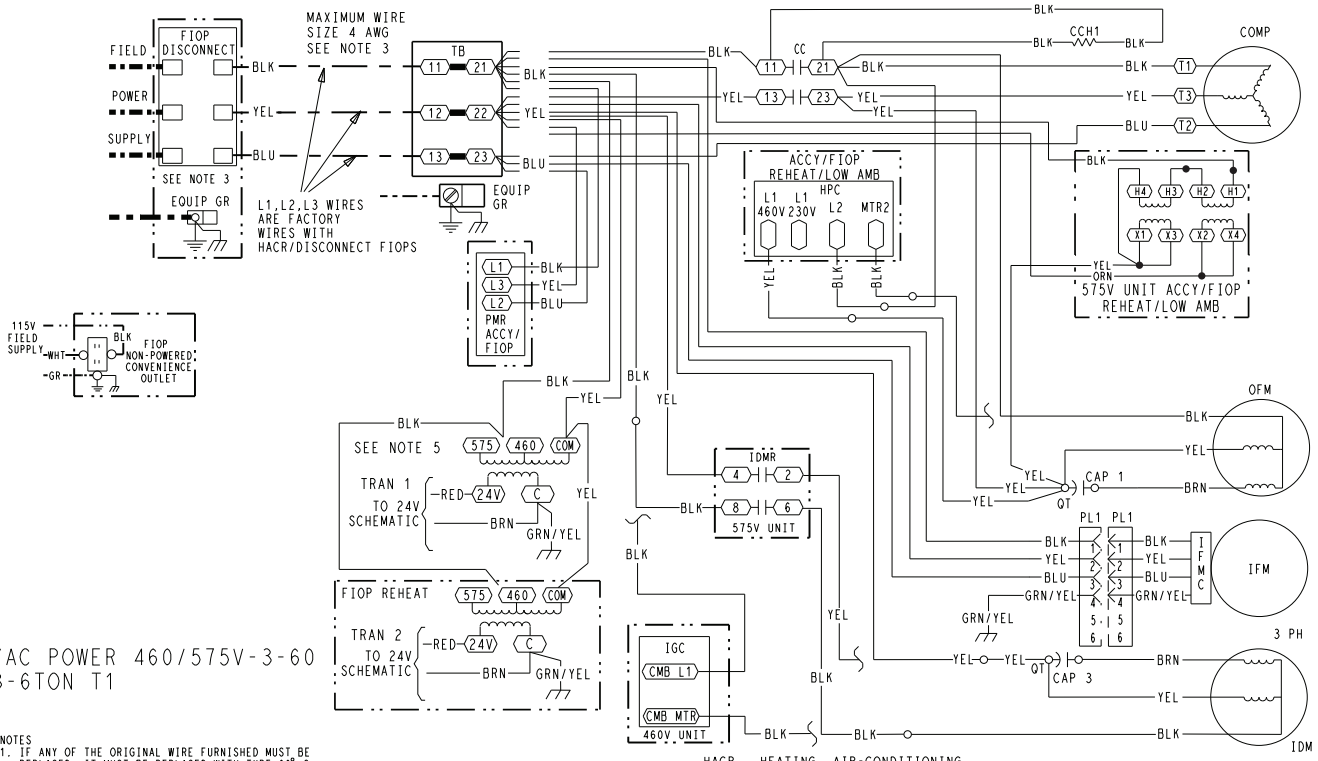

YAC POWER 460/575V-3-60  
3-6TON T1

**NOTES**

1. IF ANY OF THE ORIGINAL WIRE FURNISHED MUST BE REPLACED, IT MUST BE REPLACED WITH TYPE 90° C WIRE OR ITS EQUIVALENT.
2. COMPRESSOR AND FAN MOTORS ARE THERMALLY PROTECTED.
3. USE COPPER CONDUCTOR ONLY.
4. DO NOT DISCONNECT POWER PLUG OR SIGNAL WIRE WHILE UNDER LOAD.
5. TRANSFORMER IS DEDICATED BASED ON UNIT VOLTAGE. TAPS ONLY SHOWN TO SIMPLIFY SCHEMATIC.

**LEGEND**

- (Y) MARKED WIRE
- (X) TERMINAL (MARKED)
- ( ) TERMINAL (UNMARKED)
- (X) TERMINAL BLOCK
- SPLICE
- SPLICE (MARKED)
- FACTORY WIRING
- - - FIELD CONTROL WIRING
- - - - FIELD POWER WIRING
- · - · - · CIRCUIT BOARD TRACE
- · - · - · ACCESSORY OR OPTIONAL WIRING

- ACCY ACCESSORY
- AUX AUXILIARY
- AWG AMERICAN WIRE GAGE
- BA BUILDING AUTOMATION NETWORK
- CC CONTACTOR, COMPRESSOR
- C COMMON
- CAP CAPACITOR
- CB CIRCUIT BREAKER
- CCH CRANKCASE HEATER
- CCHR CRANKCASE HEATER RELAY
- CCHTS CRANKCASE HEATER TEMP SWITCH
- CLO COMPRESSOR LOCKOUT
- CLV COOLING LIQUID VALVE
- CMB CENTRIFUGAL MOTOR BLOWER
- COFS CONDENSATE OVERFLOW SWITCH
- COM SIGNAL COMMON
- COMP COMPRESSOR MOTOR
- DDC DIRECT DIGITAL CONTROL
- DFB DEFROST BOARD
- DFT DEFROST THERMOSTAT
- EHR ELECTRIC HEAT RELAY
- ENTH ENTHALPY
- EQUIP EQUIPMENT
- ERV ENERGY RECOVERY VENTILATOR
- ESL ENTHALPY SENSOR - LOW
- FB FUSE BLOCK
- FIOP FACTORY INSTALLED OPTION
- FPT FREEZE PROTECTION THERMOSTAT
- FS FLAME SWITCH
- FST FAN HOUSING TEMP SENSOR
- FU FUSE
- G THERMOSTAT FAN CALL
- GR(ND) GROUND
- GV GAS VALVE

- HACR HEATING, AIR-CONDITIONING, REFRIGERATION BREAKER
- HGRH HOT GAS REHEAT
- HPC HEAD PRESSURE CONTROL
- HPS HIGH PRESSURE SWITCH
- HR HEATER RELAY
- HUM HUMIDISTAT
- IAQ INDOOR AIR QUALITY SENSORS
- IDM INDUCED DRAFT MOTOR
- IDMR INDUCED DRAFT MOTOR RELAY
- IFM INDOOR FAN MOTOR
- IFMC INDOOR FAN MOTOR CONTROL
- IFO INDOOR FAN ON SIGNAL
- IGC INTEGRATED GAS CONTROL
- I IGNITOR
- IRH INDOOR RELATIVE HUMIDITY
- JMP JUMPER
- LINE 1
- LA LOW AMBIENT LOCKOUT
- LAR LOW AMBIENT RELAY
- LAS LOW AMBIENT SWITCH
- LDR COMPRESSOR LOADER
- LEN LOCAL EQUIPMENT NETWORK
- LOC LOSS OF CHARGE
- LOOP CURRENT LOOP POWER
- LPS LOW PRESSURE SWITCH
- LS LIMIT SWITCH
- LSM LIMIT SWITCH (MANUAL RESET)
- L1LO LOW TEMP LOCKOUT
- MBB MAIN BASE BOARD
- MOV METAL OXIDE VARISTOR
- MTR MOTOR
- OAO OUTDOOR AIR QUALITY
- OAT OUTDOOR AIR TEMP. SEN
- OFM OUTDOOR FAN MOTOR
- OFR OUTDOOR FAN RELAY

- OL OVERLOAD
- PER POWER EXHAUST RELAY
- PH PHASE
- PL PLUG ASSEMBLY
- POT POTENTIOMETER
- PMR PHASE MONITOR RELAY
- PS PRESSURE SWITCH
- PWM PULSE WIDTH MODULATION
- QT QUADRUPLER TERMINA
- R THERMOSTAT POWER
- RAT RETURN AIR TEMP. SEN
- RDV REHEAT DISCHARGE VALVE
- RH RELATIVE HUMIDITY
- RLV REHEAT LIQUID VALVE
- RNET LOCAL ACCESS NETWORK
- RS ROLLOUT SWITCH
- RVS REVERSING VALVE SOLENOID
- SAT SUPPLY AIR TEMP SENSOR
- SDP SYSTEM DISCHARGE PRESSURE
- SPRH SPACE RELATIVE HUMIDITY
- SPT SPACE TEMPERATURE SENSOR
- SPTO SPACE TEMPERATURE OFFSET
- SPP SYSTEM SUCTION PRESSURE
- STD STANDARD
- SW SWITCH
- TB TERMINAL BLOCK
- TDR TIME DELAY RELAY
- TRAN TRANSFORMER
- UCB UNIT CONTROL BOARD
- W1 1st STAGE OF HEATING CALL
- W2 2nd STAGE OF HEATING CALL
- Y1 1st STAGE OF COOLING CALL
- Y2 2nd STAGE OF COOLING CALL

48TC002992 -







# TYPICAL CONTROL WIRING DIAGRAM — RAV072 460-575/3/60 UNIT WITH ELECTRO-MECHANICAL CONTROL AND W7220 ECONOMIZER

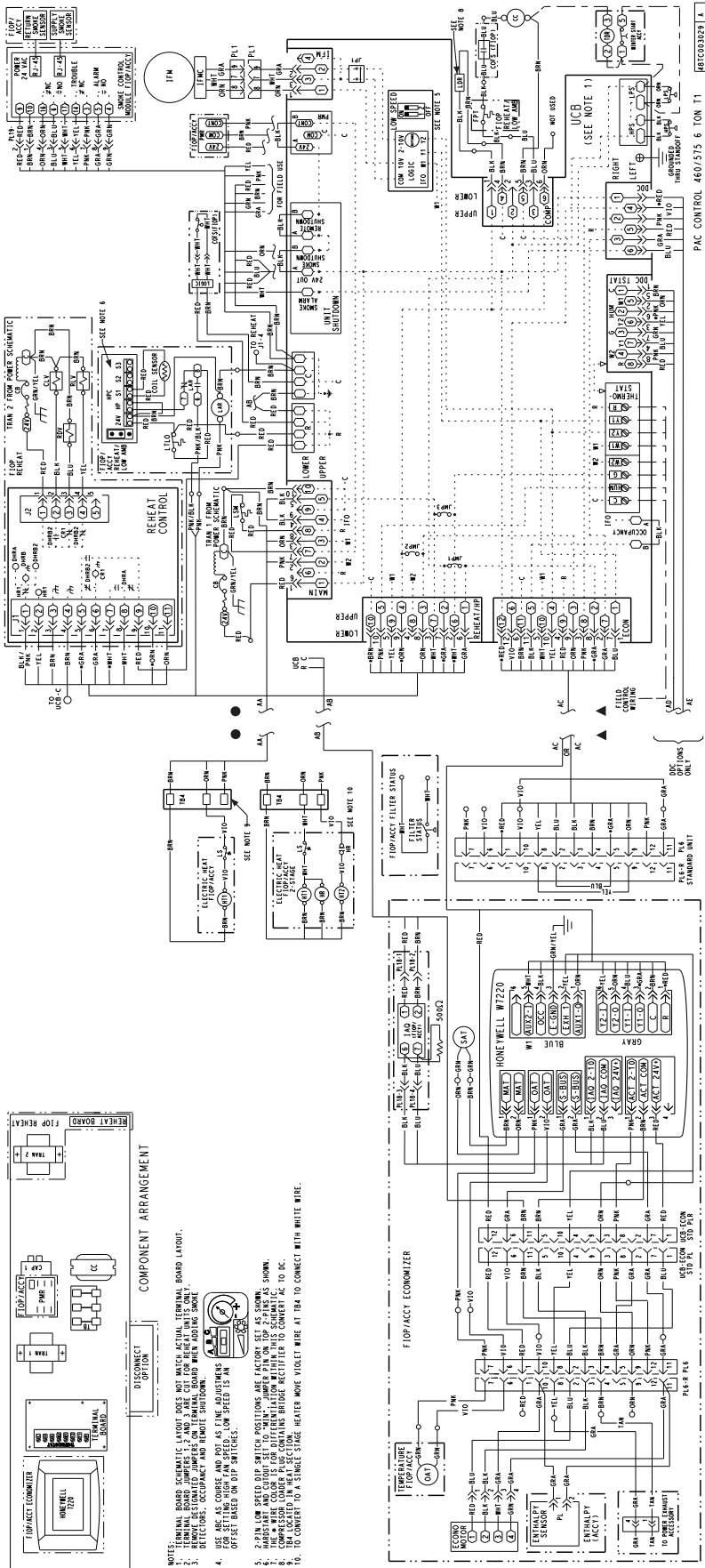

# Typical wiring diagrams (cont)

TYPICAL RAV036-072 POWER WIRING DIAGRAM, 208-230/3/60 UNIT SHOWN

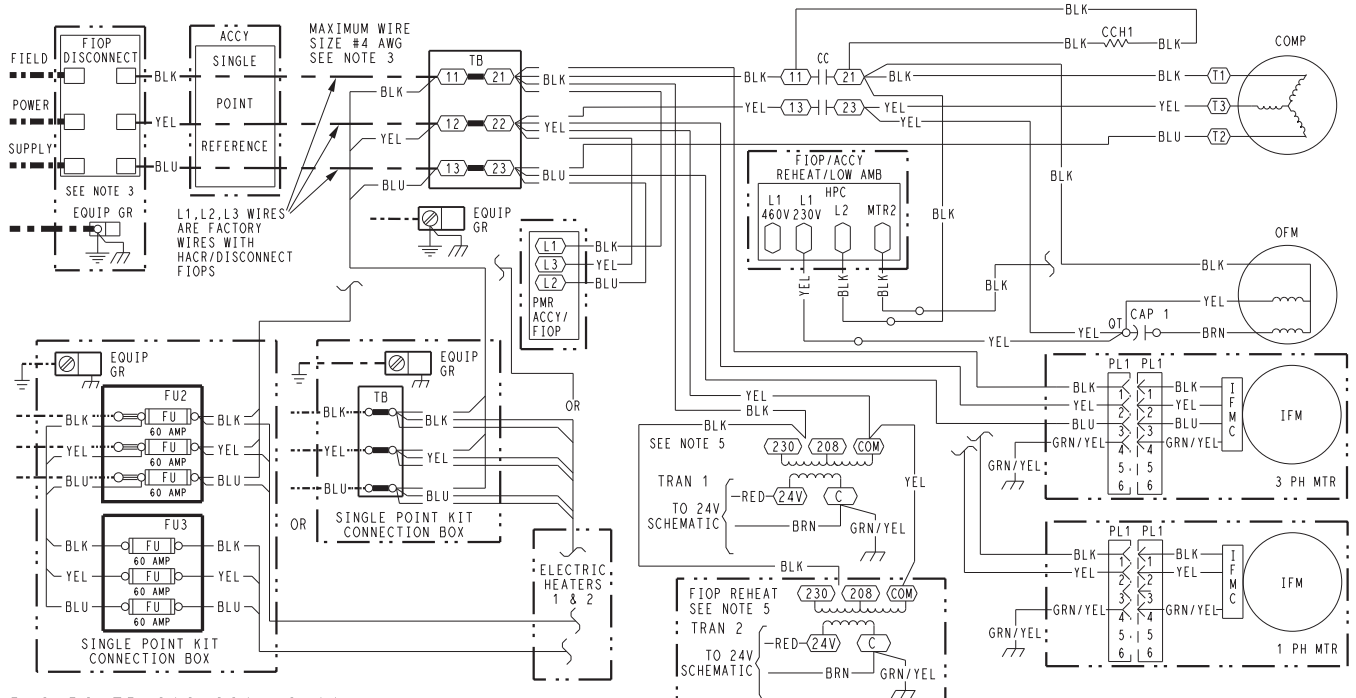

PAC POWER 208/230V-3-60H  
3-6TON T1

- NOTES
- IF ANY OF THE ORIGINAL WIRE FURNISHED MUST BE REPLACED, IT MUST BE REPLACED WITH TYPE 90° C WIRE OR ITS EQUIVALENT.
  - COMPRESSOR AND FAN MOTORS ARE THERMALLY PROTECTED.
  - USE COPPER CONDUCTOR ONLY.
  - DO NOT DISCONNECT POWER PLUG OR SIGNAL WIRE WHILE UNDER LOAD.
  - ON 208/230V UNITS, TRAN IS WIRED FOR 230V. IF UNIT IS TO BE RUN WITH 208V POWER SUPPLY, DISCONNECT BLK WIRE FROM 230V TAP AND CONNECT TO 208V TAP.

**LEGEND**

- (X) MARKED WIRE
- (X) TERMINAL (MARKED)
- ( ) TERMINAL (UNMARKED)
- (X) TERMINAL BLOCK
- SPLICE
- ( ) SPLICE (MARKED)
- FACTORY WIRING
- - - FIELD CONTROL WIRING
- - - FIELD POWER WIRING
- - - CIRCUIT BOARD TRACE
- - - ACCESSORY OR OPTIONAL WIRING

- |      |                              |          |  |
|------|------------------------------|----------|--|
| ACCY | ACCESSORY                    | G        | GROUND   |
| AWG  | AMERICAN WIRE GAGE           | GR(ND)   | GROUND   |
| BAS  | BUILDING AUTOMATION NETWORK  | HACR     | HEATING, AIR-CONDITIONING, REFRIGERATION BREAKER |
| CC   | CONTACTOR, COMPRESSOR        | HR       | HEATER RELAY                                     |
| C    | COMMON                       | HGRH     | HOT GAS REHEAT                                   |
| CAP  | CAPACITOR                    | HPC      | HEAD PRESSURE CONTROL                            |
| CB   | CIRCUIT BREAKER              | HPS      | HIGH PRESSURE SWITCH                             |
| CCHR | CRANKCASE HEATER             | HUM      | HUMIDISTAT                                       |
| CCHT | CRANKCASE HEATER RELAY       | IAQ      | INDOOR AIR QUALITY SENSORS                       |
| CLO  | COMPRESSOR LOCKOUT           | IFM      | INDOOR FAN MOTOR                                 |
| CLV  | COOLING LIQUID VALVE         | IFMC     | INDOOR FAN MOTOR CONTROL                         |
| COPS | CONDENSATE OVERFLOW SWITCH   | IFO      | INDOOR FAN ON SIGNAL                             |
| COM  | SIGNAL COMMON                | IRH      | INDOOR RELATIVE HUMIDITY                         |
| COMP | COMPRESSOR MOTOR             | JMP      | JUMPER   |
| DC   | DIRECT DIGITAL CONTROL       | L1       | LINE 1   |
| DFB  | DEFROST BOARD                | LA       | LOW AMBIENT LOCKOUT                              |
| DFT  | DEFROST THERMOSTAT           | LAR      | LOW AMBIENT RELAY                                |
| EHR  | ELECTRIC HEAT RELAY          | LAS      | LOW AMBIENT SWITCH                               |
| ENTH | ENTHALPY                     | LDR      | COMPRESSOR LOADER                                |
| ERV  | ENERGY RECOVERY VENTILATOR   | LEN      | LOCAL EQUIPMENT NETWORK                          |
| ESL  | ENTHALPY SENSOR - LOW        | LOC      | LOSS OF CHARGE                                   |
| FB   | FUSE BLOCK                   | LOOP PWR | CURRENT LOOP POWER                               |
| FIOP | FACTORY INSTALLED OPTION     | LPS      | LOW PRESSURE SWITCH                              |
| FPT  | FREEZE PROTECTION THERMOSTAT | LS       | LIMIT SWITCH                                     |
| FST  | FAN HOUSING TEMP SENSOR      | LSM      | LIMIT SWITCH (MANUAL RESET)                      |
| FU   | FUSE                         | LTO      | LOW TEMP LOCKOUT                                 |

- |      |                           |
|------|---------------------------|
| MBB  | MAIN BASE BOARD           |
| MOV  | METAL OXIDE VARISTOR      |
| MTR  | MOTOR                     |
| OAO  | OUTDOOR AIR QUALITY       |
| OAT  | OUTDOOR AIR TEMP. SEN     |
| OFM  | OUTDOOR FAN MOTOR         |
| OFR  | OUTDOOR FAN RELAY         |
| OL   | OVERLOAD                  |
| PER  | POWER EXHAUST RELAY       |
| PH   | PHASE                     |
| PL   | PLUG ASSEMBLY             |
| POT  | POTENTIOMETER             |
| PMR  | PHASE MONITOR RELAY       |
| PS   | PRESSURE SWITCH           |
| PWM  | PULSE WIDTH MODULATION    |
| QT   | QUADRUPLE TERMINAL        |
| QFN  | QUADRIPLY TERMINAL        |
| R    | REFRIGERANT RELAY         |
| RAT  | RETURN AIR TEMP. SEN      |
| RDV  | REHEAT DISCHARGE VALVE    |
| RH   | RELATIVE HUMIDITY         |
| RLV  | REHEAT LIQUID VALVE       |
| RNET | LOCAL ACCESS NETWORK      |
| RVS  | REVERSING VALVE SOLENOID  |
| SAT  | SUPPLY AIR TEMP. SENSOR   |
| SDP  | SYSTEM DISCHARGE PRESSURE |
| SPRH | SPACE RELATIVE HUMIDITY   |
| SPT  | SPACE TEMPERATURE SENSOR  |
| SPTO | SPACE TEMPERATURE OFFSET  |
| SSP  | SYSTEM SUCTION PRESSURE   |
| SW   | SWITCH                    |
| TB   | TERMINAL BLOCK            |
| TDR  | TIME DELAY RELAY          |
| TRAN | TRANSFORMER               |
| UCB  | UNIT CONTROL BOARD        |
| W1   | 1st STAGE OF HEATING CALL |
| W2   | 2nd STAGE OF HEATING CALL |
| Y1   | 1st STAGE OF COOLING CALL |
| Y2   | 2nd STAGE OF COOLING CALL |

48TC002994 -

## TYPICAL RAV036-072 POWER WIRING DIAGRAM, 460-575/3/60 UNIT SHOWN

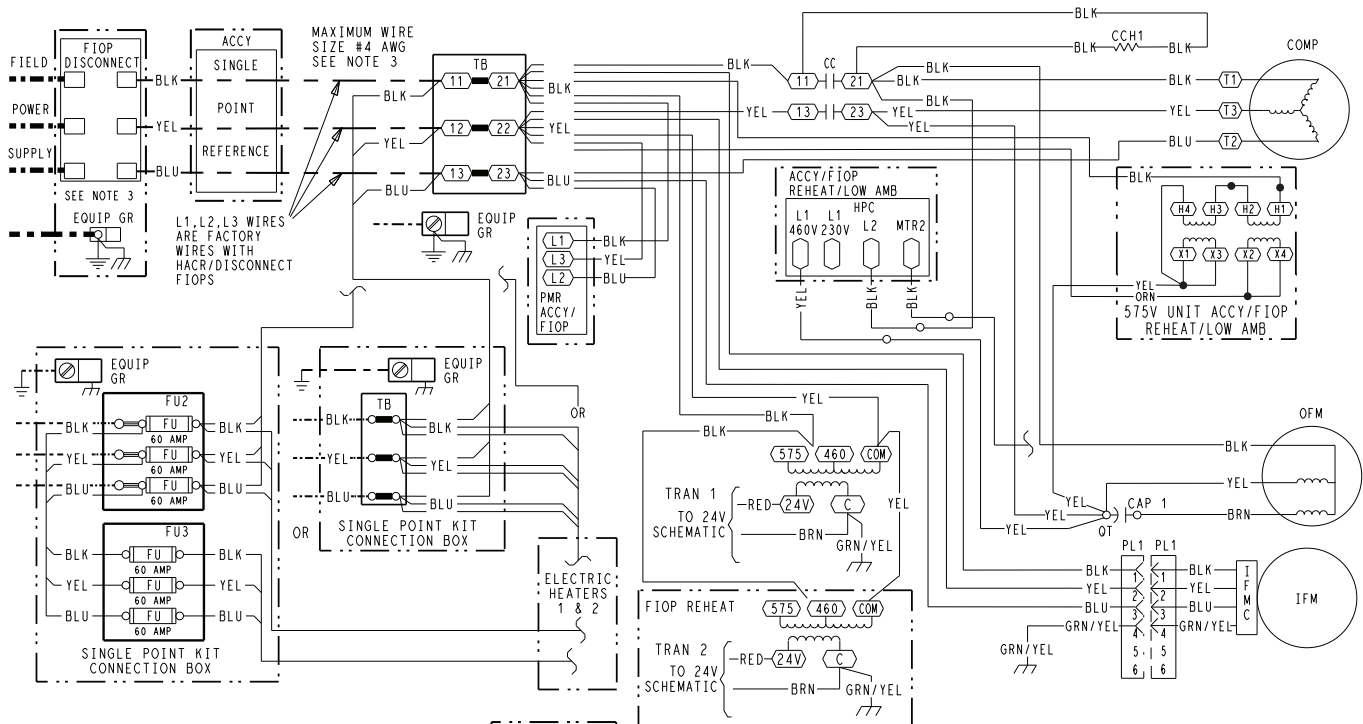

PAC POWER 460/575V-3-60  
3-6TON T1

- NOTES**
- IF ANY OF THE ORIGINAL WIRE FURNISHED MUST BE REPLACED, IT MUST BE REPLACED WITH TYPE 90° C WIRE OR ITS EQUIVALENT.
  - COMPRESSOR AND FAN MOTORS ARE THERMALLY PROTECTED.
  - USE COPPER CONDUCTOR ONLY.
  - DO NOT DISCONNECT POWER PLUG OR SIGNAL WIRE WHILE UNDER LOAD.
  - TRANSFORMER IS DEDICATED BASED ON UNIT VOLTAGE. TAPS ONLY SHOWN TO SIMPLIFY SCHEMATIC.

**LEGEND**

- X MARKED WIRE
- TERMINAL (MARKED)
- TERMINAL (UNMARKED)
- X TERMINAL BLOCK
- SPLICE
- SPLICE (MARKED)
- FACTORY WIRING
- - - FIELD CONTROL WIRING
- - - - - FIELD POWER WIRING
- - - - - CIRCUIT BOARD TRACE
- - - - - ACCESSORY OR OPTIONAL WIRING

ACCY	ACCESSORY	G	GROUND	THR	THERMOSTAT FAN CALL
AWG	AMERICAN WIRE GAGE	GR(ND)	GROUND	HGRH	HOT GAS REHEAT
BAS	BUILDING AUTOMATION NETWORK	HACR	HEATING, AIR-CONDITIONING, REFRIGERATION BREAKER	HPC	HEAD PRESSURE CONTROL
CC	CONTACTOR, COMPRESSOR	C	COMMON	HPS	HIGH PRESSURE SWITCH
C	CAPACITOR	HR	HEATER RELAY	HUM	HUMIDISTAT
CAP	CAPACITOR	IAQ	INDOOR AIR QUALITY SENSORS	IRH	INDOOR RELATIVE HUMIDITY
CB	CIRCUIT BREAKER	IFM	INDOOR FAN MOTOR	JMP	JUMPER
CCH	CRANKCASE HEATER	L1	LINE 1	L1	LINE 1
CCH1	CRANKCASE HEATER RELAY	LA	LOW AMBIENT LOCKOUT	LA	LOW AMBIENT LOCKOUT
CCHTS	CRANKCASE HEATER TEMP SWITCH	LAR	LOW AMBIENT RELAY	LAS	LOW AMBIENT SWITCH
CLO	COMPRESSOR LOCKOUT	LDR	COMPRESSOR LOADER	LEN	LOCAL EQUIPMENT NETWORK
CLV	COOLING LIQUID VALVE	LOC	LOSS OF CHARGE	LPS	LOW PRESSURE SWITCH
COFS	CONDENSATE OVERFLOW SWITCH	LOOP PWR	CURRENT LOOP POWER	LS	LIMIT SWITCH
COM	SIGNAL COMMON	LSM	LIMIT SWITCH (MANUAL RESET)	LTLO	LOW TEMP LOCKOUT
COMP	COMPRESSOR MOTOR				
DDC	DIRECT DIGITAL CONTROL				
DFB	DEFROST BOARD				
DFT	DEFROST THERMOSTAT				
EHR	ELECTRIC HEAT RELAY				
ENTH	ENTHALPY				
ERV	ENERGY RECOVERY VENTILATOR				
ESL	ENTHALPY SENSOR - LOW				
FB	FUSE BLOCK				
FIOF	FACTORY INSTALLED OPTION				
FPT	FREEZE PROTECTION THERMOSTAT				
FST	FAN HOUSING TEMP SENSOR				
FU	FUSE				

48TC002995 -

# Sequence of operation

## General

The sequence below describes the sequence of operation for an electro-mechanical unit with and without a factory-installed EconoMiSer® IV (W7212 controller) and X (W7220 controller). For information regarding a direct digital controller, see the start-up, operations, and troubleshooting manual for the applicable controller.

## Electro-Mechanical Units with No Economizer

### Cooling (single stage units)

When the thermostat calls for cooling, terminals G and Y1 are energized. The indoor fan will run at the user set fan speed and the compressor contactor (CC) is energized causing the compressor and outdoor fan to run.

When the thermostat removes the call for Y1, the compressor contactor will de-energize shutting down the compressor and the outdoor fan. When the thermostat removes the call for G, the indoor fan will turn off after the specific unit fan off delay.

### Cooling (two stage units)

When the thermostat calls for cooling, terminals G and Y1 are energized. The indoor fan will run at the low fan speed and the compressor contactor (CC) is energized causing the compressor and outdoor fan to run. The low indoor fan speed is 66% of the user set fan speed and the compressor will run at partial capacity.

If additional cooling is needed, the thermostat will add the call for Y2. This will increase the indoor fan speed to the user set fan speed and energize the compressor loader for full compressor capacity. The outdoor fan is the same speed for Y1 and Y2.

When the thermostat removes the call for Y2 but leaves the Y1, the indoor fan will reduce speed to 66% of the user set fan speed, the compressor loader will turn off, and the outdoor fan will remain on. When the thermostat removes the call for Y1 the compressor contactor will de-energize shutting down the compressor and the outdoor fan. When the thermostat removes the call for G, the indoor fan will turn off after the specific unit fan off delay.

NOTE: Per ASHRAE 90.1-2016 and IECC-2018 standards, during the first stage of cooling operation the Unit Control Board (UCB) will adjust the fan motor speed to provide 66% of the total cfm established for the unit.

### Gas Heating (RGV units)

NOTE: Units have either 1 or 2 stages of gas heat.

When the thermostat calls for heating, power is sent to W on the Integrated Gas Controller (IGC) board. An LED (light-emitting diode) on the IGC board turns on and remains on during normal operation. A check is made to ensure that the roll-out switch and limit switch are closed. If the check was successful, the induced-draft motor is energized, and when its speed is satisfactory, as proven by the flue gas pressure switch, the ignition activation period begins. The burners will ignite within 5 seconds. If the burners do not light, there is a 22 second delay before another 5 second attempt. This sequence is repeated for 15 minutes or until the burners light. If, after the 15 minutes, the burners still have not lit, heating is locked out. To reset the control, break 24v power to the thermostat.

When ignition occurs, the IGC board will continue to monitor the condition of the roll-out switch, the limit switches, the flue gas pressure switch, as well as the flame sensor. 45 seconds after ignition occurs, assuming the unit is controlled through a room thermostat set for fan auto, the indoor-fan motor will energize (and the outdoor-air dampers will open to their minimum position). If, for some reason, the over-temperature limit opens prior to the start of the indoor fan blower, the unit will shorten the 45 second delay to 5 seconds less than the time from initiation of heat to when the limit tripped. Gas will not be interrupted to the burners and heating will continue. Once the fan-on delay has been modified, it will not change back to 45 seconds until power is reset to the control. On units with 2 stages of heat, when additional heat is required, W2 closes and initiates power to the second stage of the main gas valve. When the thermostat is satisfied, W1 and W2 open and the gas valve closes, interrupting the flow of gas to the main burners. If the unit is controlled through a room thermostat set for fan auto, the indoor-fan motor will continue to operate for an additional 45 seconds then stop. A LED indicator is provided on the IGC to monitor operation.

### Electric Heating (RAV units)

NOTE: RAV units are sold as cooling only. If electric heaters are required, use only factory-approved heaters. They will operate as follows.

Units have either 1 or 2 stages of electric heat. When the thermostat calls for heating, power is applied to G and the W1 terminals at the unit. The unit control will energize the indoor fan contactor and the first stage of electric heat. On units with two-stage heating, when additional heating is required, the second stage of electric heat (if equipped) will be energized when power is applied at the W2 terminal on the unit.

<p><b>IMPORTANT:</b> The thermostat must be configured for Electric Heat so it will energize G with the W1 call.</p>
--

## Electro-mechanical Units with Factory-Installed EconoMiSer

When free cooling is not available, the compressors will be controlled by the zone thermostat. When free cooling is available, the outdoor-air damper is modulated by the EconoMiSer IV and X control to provide a 50°F (10°C) to 55°F (13°C) mixed-air temperature into the zone. As the mixed air temperature fluctuates above 55°F (13°C) or below 50°F (10°C) dampers will be modulated (open or close) to bring the mixed-air temperature back within control. If mechanical cooling is utilized with free cooling, the outdoor-air damper will maintain its current position at the time the compressor is started. If the increase in cooling capacity causes the mixed-air temperature to drop below 45°F (7°C), then the outdoor-air damper position will be decreased to the minimum position. If the mixed-air temperature continues to fall, the outdoor-air damper will close. Control returns to normal once the mixed-air temperature rises above 48°F (9°C). The power exhaust fans will be energized and de-energized, if installed, as the outdoor-air damper opens and closes.

If field-installed accessory CO<sub>2</sub> sensors are connected to the EconoMiSer® IV and X control, a demand controlled ventilation strategy will begin to operate. As the CO<sub>2</sub> level in the zone increases above the CO<sub>2</sub> set-point, the minimum position of the damper will be increased proportionally. As the CO<sub>2</sub> level decreases because of the increase in fresh air, the outdoor-air damper will be proportionally closed. For EconoMiSer IV and X operation, there must be a thermostat call for the fan (G). If the unit is occupied and the fan is on, the damper will operate at minimum position. Otherwise, the damper will be closed.

When the EconoMiSer IV and X control is in the occupied mode and a call for cooling exists (Y1 on the thermostat), the control will first check for indoor fan operation. If the fan is not on, then cooling will not be activated. If the fan is on, then the control will open the EconoMiSer IV and X damper to the minimum position.

On the initial power to the EconoMiSer IV and X control, it will take the damper up to 2½ minutes before it begins to position itself. After the initial power-up, further changes in damper position can take up to 30 seconds to initiate. Damper movement from full closed to full open (or vice versa) will take between 1½ and 2½ minutes. If free cooling can be used as determined from the appropriate changeover command (switch, dry bulb, enthalpy curve, differential dry bulb, or differential enthalpy), then the control will modulate the dampers open to maintain the mixed-air temperature set-point at 50°F (10°C) to 55°F (13°C). If there is a further demand for cooling (cooling second stage — Y2 is energized), then the control will bring on compressor stage 1 to maintain the mixed-air temperature set-point. The EconoMiSer IV and X damper will be open at maximum position.

**2-Speed Note:** The EconoMiSer IV and X controller will adjust the damper position as the Indoor Fan Speed changes, per its configured values.

### Heating

The sequence of operation for the heating is the same as an electro-mechanical unit with no economizer. The only difference is how the economizer acts. The economizer will stay at the Economizer Minimum Position while the evaporator fan is operating. The outdoor-air damper is closed when the indoor fan is not operating. Refer to Service and Maintenance Manual for further details.

### Optional Hot Gas Re-Heat dehumidification system

Units with the factory-equipped Hot Gas Re-Heat system option are capable of providing multiple modes of improved dehumidification as a variation of the normal cooling cycle. The Hot Gas Re-Heat system option includes additional valves in the liquid line and discharge line of each refrigerant circuit, a small reheat condenser coil downstream of the evaporator, and variable-speed control of some or all outdoor fans. Operation of the revised refrigerant circuit for each mode is described below.

The Hot Gas Re-Heat system provides three sub-modes of operation: Cool, Reheat1, and Reheat2.

**Cool mode** — Provides a normal ratio of Sensible and Latent Cooling effect from the evaporator coil.

**Reheat1** — Provides increased Latent Cooling while slightly reducing the Sensible Cooling effect.

**Reheat2** — Provides normal Latent Cooling but with null or minimum Sensible Cooling effect delivered to the space.

The Reheat1 and Reheat2 modes are available when the unit is not in a Heating mode and when the Low Ambient Lockout switch is closed.

Refer to the following figures for single stage and 2 stage piping flow diagrams.

**NORMAL COOLING MODE — HOT GAS RE-HEAT SYSTEM WITH SINGLE STAGE COOLING**

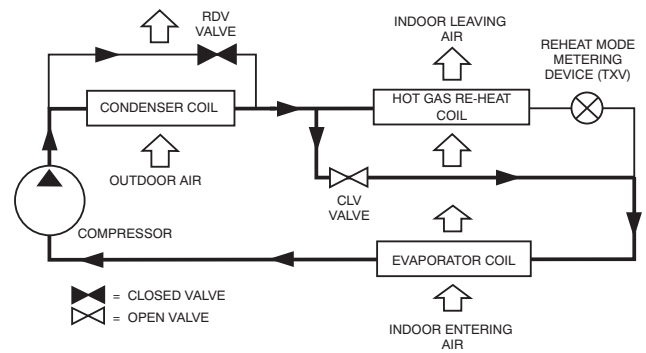

**SUBCOOLING MODE (REHEAT 1) — HOT GAS RE-HEAT SYSTEM WITH SINGLE STAGE COOLING**

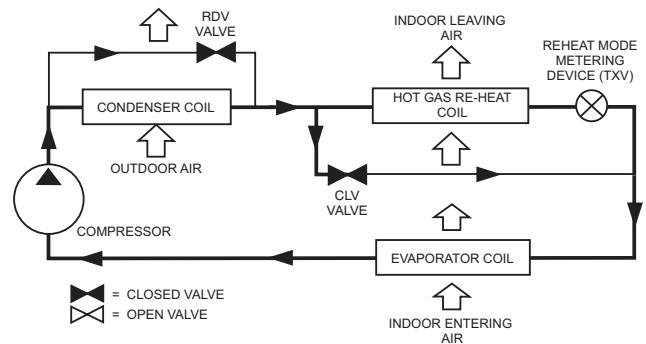

**HOT GAS REHEAT MODE (REHEAT2) — HOT GAS RE-HEAT SYSTEM WITH SINGLE STAGE COOLING**

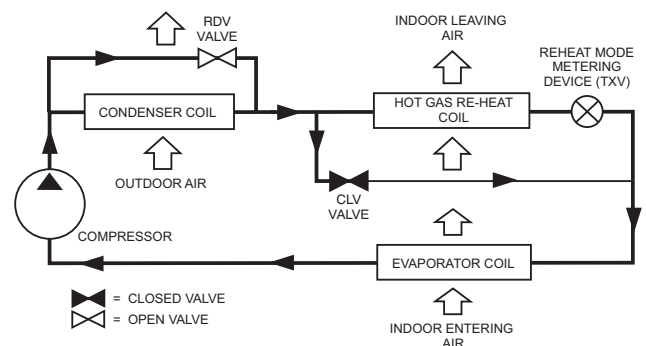

# Sequence of operation (cont)

**NORMAL COOLING MODE — HOT GAS RE-HEAT SYSTEM WITH 2 STAGE COOLING**

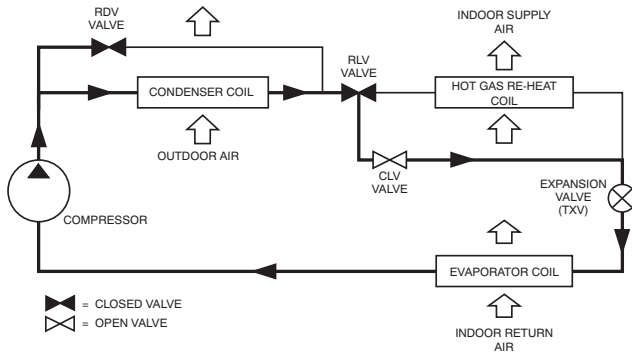

**HOT GAS REHEAT MODE (REHEAT2) — HOT GAS RE-HEAT SYSTEM WITH 2 STAGE COOLING**

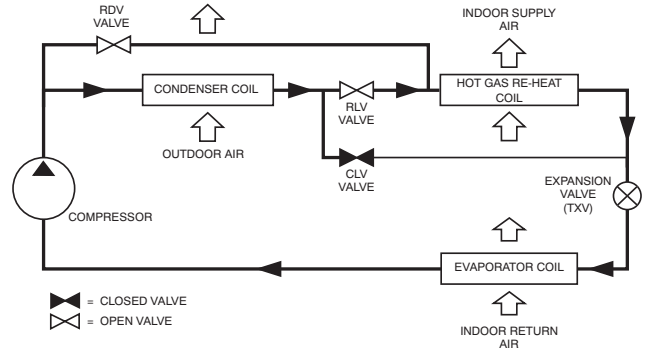

**SUBCOOLING MODE (REHEAT 1) — HOT GAS RE-HEAT SYSTEM WITH 2 STAGE COOLING**

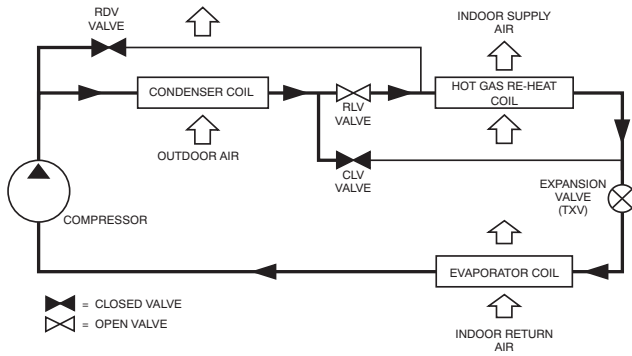

# Application data

## Minimum operating ambient temperature (cooling)

In mechanical cooling mode, your ICP rooftop unit can safely operate down to an outdoor ambient temperature of 40°F (4°C). It is possible to provide cooling at lower outdoor ambient temperatures by using less outside air, economizers, and/or accessory low ambient kits.

## Maximum operating ambient temperature (cooling)

The maximum operating ambient temperature for cooling mode is 115°F (46°C). While cooling operation above 115°F (46°C) may be possible, it could cause either a reduction in performance, reliability, or a protective action by the unit's internal safety devices.

## Multiple motor and drive packages

Some applications need larger horsepower motors, some need more airflow, and some need both. Regardless of the case, your ICP expert has a factory installed combination to meet your application. A wide selection of motors are available, factory installed, to handle nearly any application.

## Stainless steel heat exchanger (RGV units only)

The stainless steel heat exchanger option provides the tubular heat exchanger be made out of a minimum 20 gage type 409 stainless steel for applications where the mixed air to the heat exchanger is expected to drop below 45°F (7°C). Stainless steel may be specified on applications where the presence of airborne contaminants require its use (applications such as paper mills) or in area with very high outdoor humidity that may result in severe condensation in the heat exchanger during cooling operation.

## Minimum mixed air temperature (heating) (RGV units only)

Using the factory settings, the minimum temperatures for the mixed air (the combined temperature of the warm return air and the cold outdoor air) entering the dimpled, gas heat exchangers are shown in the following table.

### MINIMUM TEMPERATURE FOR MIXED AIR TEMPERATURE

ALUMINIZED	STAINLESS STEEL
50°F (10°C) Continuous	40°F (4°C) Continuous
45°F (7°C) Intermittent	35°F (2°C) Intermittent

Operating at lower mixed-air temperatures may be possible, if a field-supplied, outdoor air thermostat initiates both heat stages when the temperature is less than the minimum temperatures listed above. Please contact your local ICP representative for assistance.

## Minimum and maximum airflow (heating and cooling)

To maintain safe and reliable operation of your rooftop, operate within the heating airflow limits during heating mode and cooling airflow limits during cooling mode. Operating above the max may cause blow-off, undesired airflow noise, or airflow related problems with the rooftop unit. Operating below the min may cause problems with coil freeze-up and unsafe heating operation. Heating and cooling limitations differ when evaluating operating CFM, the minimum value is the HIGHER of the cooling and heating minimum CFM values published on page 7 and

the maximum value is the LOWER of the cooling and heating minimum values published on page 7.

## Heating-to-cooling changeover

Your unit will automatically change from heating to cooling mode when using a thermostat with an auto-change-over feature.

## Airflow

All units are draw-through in cooling mode and blow-through in heating mode.

## Outdoor air application strategies

Economizers reduce operating expenses and compressor run time by providing a free source of cooling and a means of ventilation to match application changing needs. In fact, they should be considered for most applications. Also, consider the various economizer control methods and their benefits, as well as sensors required to accomplish your application goals. Please contact your local ICP representative for assistance.

## Motor limits, break horsepower (BHP)

Due to internal design of ICP units, the air path, and specially designed motors, the full horsepower (maximum continuous BHP) band, as listed in the Fan Performance tables, can be used with the utmost confidence. There is no need for extra safety factors, as ICP motors are designed and rigorously tested to use the entire, listed BHP range without either nuisance tripping or premature motor failure.

## Propane heating (RGV units only)

Propane has different physical qualities than natural gas. As a result, propane requires different fuel to air mixture. To optimize the fuel/air mixture for propane, ICP sells different burner orifices in an easy to install accessory kit. To select the correct burner orifices or determine the heat capacity for a propane application, use either the selection software, or the unit's service manual.

## High altitude heating

High altitudes have less oxygen, which affects the fuel/air mixture in heat exchangers. In order to maintain a proper fuel/air mixture, heat exchangers operating in altitudes above 2000 ft (610 m) require different orifices. To select the correct burner orifices or determine the heat capacity for a high altitude application, use either the selection software, or the unit's service manual.

High altitudes have less oxygen, which means heat exchangers need less fuel. The new gas orifices in this field-installed kit make the necessary adjustment for high altitude applications. They restore the optimal fuel to air mixture and maintain healthy combustion on altitudes above 2000 ft (610 m).

NOTE: Typical natural gas heating value ranges from 975 to 1050 Btu/ft<sup>3</sup> at sea level nationally. The heating value goes down approximately 1.7% per every thousand feet elevation. Standard factory orifices can typically be used up to 2000 ft (610 m) elevation without any operational issues.

# Application data (cont)

## Sizing a rooftop

Bigger is not necessarily better. While an air conditioner needs to have enough capacity to meet the design loads, it does not need excess capacity. In fact, excess capacity typically results in very poor part load performance and humidity control.

Using higher design temperatures than ASHRAE recommends for your location, adding “safety factors” to the calculated load, are all signs of oversizing air conditioners. Oversizing the air conditioner leads to poor humidity control, reduced efficiency, higher utility bills, larger indoor temperature swings, excessive noise, and increased wear and tear on the air conditioner.

Rather than oversizing an air conditioner, engineers should “right-size” or even slightly “under-size” air conditioners. Correctly sizing an air conditioner controls humidity better; promotes efficiency; reduces utility bills; extends equipment life, and maintains even, comfortable temperatures. Please contact your local ICP representative for assistance.

## Low ambient applications

The optional ICP economizer can adequately cool your space by bringing in fresh, cool outside air. In fact, when so equipped, accessory low-ambient kit may not be necessary. In low ambient conditions, unless the outdoor air is excessively humid or contaminated, economizer-based “free cooling” is the preferred less costly and energy conscious method. In low ambient applications where outside air might not be desired (such as contaminated or excessively humid outdoor environments), your ICP rooftop can operate to ambient temperatures down to  $-20^{\circ}\text{F}$  ( $-29^{\circ}\text{C}$ ) using the recommended accessory low ambient controller.

**IMPORTANT:** Before using EconoMiSer® IV, 2-Position Damper or Manual Damper on RGV/RAV072 units, refer to Application Tip AB-0002 for guidance.

# Guide specifications

Note about this specification:

This specification is in the "Masterformat" as published by the Construction Specification Institute. Please feel free to copy this specification directly into your building spec.

## Gas Heat/Electric Cooling Packaged Rooftop

### HVAC Guide Specifications

Size Range: **3 to 6 Nominal Tons**

ICP Model Number: **RGV036-072**

#### Part 1 — (23 06 80) Schedules for Decentralized HVAC Equipment

1.01 (23 06 80.13) Decentralized Unitary HVAC Equipment Schedule

A. (23 06 80.13.A.) Rooftop unit (RTU) schedule:

1. Schedule is per the project specification requirements.

#### Part 2 — (23 07 16) HVAC equipment insulation

2.01 (23 07 16.13) Decentralized, Rooftop Units:

A. (23 07 16.13.A.) Evaporator fan compartment:

1. Interior cabinet surfaces shall be insulated with a minimum 1/2-in. thick, minimum 1 1/2-lb density, flexible fiberglass insulation bonded with a phenolic binder, neoprene coated on the air side.
2. Insulation and adhesive shall meet NFPA 90A requirements for flame spread and smoke generation.

B. (23 07 16.13.B.) Gas Heat Compartment:

1. Aluminum foil-faced fiberglass insulation shall be used.
2. Insulation and adhesive shall meet NFPA 90A requirements for flame spread and smoke generation.

#### Part 3 — (23 09 13) Instrumentation and control devices for HVAC

3.01 (23 09 13.23) Sensors and Transmitters

A. (23 09 13.23.A.) Thermostats

1. Thermostat must
  - a. energize both "W" and "G" when calling for heat.
  - b. have capability to energize 1 or 2 stages of cooling, and 2 different stages of heating.
  - c. include capability for occupancy scheduling.

#### Part 4 — (23 09 33) Electric and Electronic Control System for HVAC

4.01 (23 09 33.13) Decentralized, Rooftop Units:

A. (23 09 33.13.A.) General:

1. Shall be complete with self-contained low-voltage control circuit protected by a resettable circuit breaker on the 24-v transformer side. Transformer shall have 75VA capability.
2. Shall utilize color-coded wiring.
3. Shall include a Unit Control Board to conveniently and safely provide connection points for vital control functions such as: smoke

detectors, phase monitor, gas controller, economizer, thermostat, and low and high pressure switches. Controller shall also provide an intuitive means to adjust the indoor fan speed through a simple switch and pot adjustment design.

4. The heat exchanger shall be controlled by an integrated gas controller (IGC) microprocessor. See heat exchanger section of this specification.

5. Unit shall include a minimum of one 8-pin screw terminal connection board for connection of control wiring.

B. (23 09 33.13.B.) Safeties:

1. Compressor over-temperature, over-current. High internal pressure differential.

2. Low pressure switch:

a. Low pressure switch shall use different color wire than the high pressure switch. The purpose is to assist the installer and service technician to correctly wire and or troubleshoot the rooftop unit.

3. High pressure switch:

a. High pressure switch shall use different color wire than the low pressure switch. The purpose is to assist the installer and service technician to correctly wire and or troubleshoot the rooftop unit.

4. Automatic reset, motor thermal overload protector.

5. Heating section shall be provided with the following minimum protections:

a. High temperature limit switches.

b. Induced draft motor speed sensor.

c. Flame rollout switch.

d. Flame proving controls.

#### Part 5 — (23 09 93) Sequence of Operations for HVAC Controls

5.01 (23 09 93.13) Decentralized, Rooftop Units:

A. (23 09 93.13.A.) INSERT SEQUENCE OF OPERATION

#### Part 6 — (23 40 13) Panel Air Filters

6.01 (23 40 13.13) Decentralized, Rooftop Units:

A. (23 40 13.13.A.) Standard filter section:

1. Shall consist of factory installed, low velocity, disposable 2-in. thick fiberglass filters of commercially available sizes.

2. Unit shall use only one filter size. Multiple sizes are not acceptable.

3. Filters shall be accessible through an access panel with "no-tool" removal as described in the unit cabinet section of this specification (23 81 19.13.G).

# Guide specifications (cont)

## Part 7 — (23 81 19) Self-Contained Air Conditioners

### 7.01 (23 81 19.13) Small-Capacity Self-Contained Air Conditioners:

#### A. (23 81 19.13.A.) General:

1. Outdoor, rooftop mounted, electrically controlled, heating and cooling unit utilizing a fully hermetic scroll compressor(s) for cooling duty and gas combustion for heating duty.
2. Factory assembled, single-piece heating and cooling rooftop unit. Contained within the unit enclosure shall be all factory wiring, piping, controls, and special features required prior to field start-up.
3. Unit shall use R-410A refrigerant.
4. Unit shall be installed in accordance with the manufacturer's instructions.
5. Unit must be selected and installed in compliance with local, state, and federal codes.

#### B. (23 81 19.13.B.) Quality Assurance:

1. Unit meets ASHRAE 90.1 minimum efficiency requirements.
2. Unit shall be rated in accordance with AHRI Standards 210/240 (036-060 sizes) or 340/360 (072 size).
3. Unit shall be designed to conform to ASHRAE 15.
4. Unit shall be UL-tested and certified in accordance with ANSI Z21.47 Standards and UL-listed and certified under Canadian standards as a total package for safety requirements.
5. Insulation and adhesive shall meet NFPA 90A requirements for flame spread and smoke generation.
6. Unit casing shall be capable of withstanding 500 hour salt spray exposure per ASTM B117 (scribed specimen).
7. Unit shall be designed in accordance with ISO 9001, and shall be manufactured in a facility registered by ISO 9001:2015.
8. Roof curb shall be designed to conform to NRCA Standards.
9. Unit shall be subjected to a completely automated run test on the assembly line. The data for each unit will be stored at the factory, and must be available upon request.
10. Unit shall be designed in accordance with UL Standard 1995, including tested to withstand rain.
11. Unit shall be constructed to prevent intrusion of snow and tested to prevent snow intrusion into the control box up to 40 mph.
12. Unit shake tested to assurance level 1, ASTM D4169 to ensure shipping reliability.

#### C. (23 81 19.13.C.) Delivery, Storage, and Handling:

1. Unit shall be stored and handled per manufacturer's recommendations.

2. Lifted by crane requires either shipping top panel or spreader bars.
3. Unit shall only be stored or positioned in the upright position.

#### D. (23 81 19.13.D.) Project Conditions:

1. As specified in the contract.

#### E. (23 81 19.13.E.) Operating Characteristics:

1. Unit shall be capable of starting and running at 115°F (46°C) ambient outdoor temperature, meeting maximum load criteria of AHRI Standard 210/240 or 340/360 at ±10% voltage.
2. Compressor with standard controls shall be capable of operation down to 40°F (4°C), ambient outdoor temperatures. Accessory winter start kit is necessary if mechanically cooling at ambient temperatures down to 25°F (-4°C).
3. Unit shall discharge supply air vertically or horizontally as shown on contract drawings.
4. Unit shall be factory configured for vertical supply and return configurations.
5. Unit shall be field convertible from vertical to horizontal airflow on all models. No special kit required.
6. Unit shall be capable of mixed operation: vertical supply with horizontal return or horizontal supply with vertical return.

#### F. (23 81 19.13.F.) Electrical Requirements:

1. Main power supply voltage, phase, and frequency must match those required by the manufacturer.

#### G. (23 81 19.13.G.) Unit Cabinet:

1. Unit cabinet shall be constructed of galvanized steel, and shall be bonderized and coated with a pre-painted baked enamel finish on all externally exposed surfaces.
2. Unit cabinet exterior paint shall be: film thickness, (dry) 0.003 inches minimum, gloss (per ASTM D523, 60°F/16°C): 60, Hardness: H-2H Pencil hardness.
3. Evaporator fan compartment interior cabinet insulation shall conform to AHRI Standards 210/240 and or 340/360 minimum exterior sweat criteria. Interior surfaces shall be insulated with a minimum 1/2-in. thick, 1 lb density, flexible fiberglass insulation, neoprene coated on the air side. Aluminum foil-faced fiberglass insulation shall be used in the gas heat compartment.
4. Base of unit shall have a minimum of four locations for thru-the-base gas and electrical connections (factory-installed or field-installed), standard.
5. Base Rail:
  - a. Unit shall have base rails on a minimum of 2 sides.

- b. Holes shall be provided in the base rails for rigging shackles to facilitate maneuvering and overhead rigging.
  - c. Holes shall be provided in the base rail for moving the rooftop by fork truck.
  - d. Base rail shall be a minimum of 16 gage thickness.
6. Condensate pan and connections:
- a. Shall be a sloped condensate drain pan made of a corrosion resistant material.
  - b. Shall comply with ASHRAE Standard 62.
  - c. Shall use a  $\frac{3}{4}$ -in. 14 NPT drain connection, possible either through the bottom or side of the drain pan. Connection shall be made per manufacturer's recommendations.
7. Top panel:
- a. Shall be a single piece top panel on all sizes.
8. Gas Connections:
- a. All gas piping connecting to unit gas valve shall enter the unit cabinet at a single location on side of unit (horizontal plane).
  - b. Thru-the-base capability:
    - 1) Standard unit shall have a thru-the-base gas-line location using a raised, embossed portion of the unit basepan.
    - 2) Optional, factory approved, water-tight connection method must be used for thru-the-base gas connections.
    - 3) No basepan penetration, other than those authorized by the manufacturer, is permitted.
9. Electrical Connections:
- a. All unit power wiring shall enter unit cabinet at a single, factory prepared, knockout location.
  - b. Thru-the-base capability.
    - 1) Standard unit shall have a thru-the-base electrical location(s) using a raised, embossed portion of the unit basepan.
    - 2) Optional, factory approved, water-tight connection method must be used for thru-the-base electrical connections.
    - 3) No basepan penetration, other than those authorized by the manufacturer, is permitted.
10. Component access panels (standard):
- a. Cabinet panels shall be easily removable for servicing.
  - b. Unit shall have one factory installed, tool-less, removable, filter access panel.
  - c. Panels covering control box, indoor fan, indoor fan motor, gas components (where applicable), and compressors shall have molded composite handles.
  - d. Handles shall be UV modified, composite. They shall be permanently attached, and recessed into the panel.
  - e. Screws on the vertical portion of all removable access panel shall engage into heat resistant, molded composite collars.
  - f. Collars shall be removable and easily replaceable using manufacturer recommended parts.
- H. (23 81 19.13.H.) Gas Heat:
1. General:
    - a. Heat exchanger shall be an induced draft design. Positive pressure heat exchanger designs shall not be allowed.
    - b. Shall incorporate a direct-spark ignition system and redundant main gas valve.
    - c. Gas supply pressure at the inlet to the rooftop unit gas valve must match that required by the manufacturer.
  2. The heat exchanger shall be controlled by an integrated gas controller (IGC) microprocessor.
    - a. IGC board shall notify users of fault using an LED (light-emitting diode).
    - b. The LED shall be visible without removing the control box access panel.
    - c. IGC board shall contain algorithms that modify evaporator fan operation to prevent future cycling on high temperature limit switch.
    - d. Unit shall be equipped with anti-cycle protection with one short cycle on unit flame rollout switch or 4 continuous short cycles on the high temperature limit switch. Fault indication shall be made using an LED.
  3. Standard Heat Exchanger construction:
    - a. Heat exchanger shall be of the tubular-section type constructed of a minimum of 20-gage steel coated with a nominal 1.2 mil aluminum-silicone alloy for corrosion resistance.
    - b. Burners shall be of the in-shot type constructed of aluminum-coated steel.
    - c. Burners shall incorporate orifices for rated heat output up to 2000 ft (610 m) elevation. Additional accessory kits may be required for applications above 2000 ft (610 m) elevation, depending on local gas supply conditions.
    - d. Each heat exchanger tube shall contain multiple dimples for increased heating effectiveness.
  4. Optional Stainless Steel Heat Exchanger construction:
    - a. Use energy saving, direct-spark ignition system.
    - b. Use a redundant main gas valve.

## Guide specifications (cont)

- c. Burners shall be of the in-shot type constructed of aluminum-coated steel.
  - d. All gas piping shall enter the unit cabinet at a single location on side of unit (horizontal plane).
  - e. The optional stainless steel heat exchanger shall be of the tubular-section type, constructed of a minimum of 20-gage type 409 stainless steel.
  - f. Type 409 stainless steel shall be used in heat exchanger tubes and vestibule plate.
  - g. Complete stainless steel heat exchanger allows for greater application flexibility.
5. Optional Low NOx Heat Exchanger construction:
- a. Low NOx reduction shall be provided to reduce nitrous oxide emissions to meet California's Air Quality Management District (SCAQMD) low-NOx emissions requirement of 40 nanograms per joule or less.
  - b. Primary tubes and vestibule plates on low NOx units shall be 409 stainless steel. Other components shall be aluminized steel.
6. Induced draft combustion motor and blower:
- a. Shall be a direct-drive, single inlet, forward-curved centrifugal type.
  - b. Shall be made from steel with a corrosion resistant finish.
  - c. Shall have permanently lubricated sealed bearings.
  - d. Shall have inherent thermal overload protection.
  - e. Shall have an automatic reset feature.
- I. (23 81 19.13.I.) Coils:
1. Standard Aluminum Fin-Copper Tube Coils:
    - a. Standard evaporator and condenser coils shall have aluminum lanced plate fins mechanically bonded to seamless internally grooved copper tubes with all joints brazed.
    - b. Evaporator coils shall be leak tested to 150 psig, pressure tested to 450 psig, and qualified to UL 1995 burst test at 1775 psig.
    - c. Condenser coils shall be leak tested to 150 psig, pressure tested to 650 psig, and qualified to UL 1995 burst test at 1980 psig.
  2. Optional Pre-coated aluminum-fin condenser coils (3 Phase Models Only):
    - a. Shall have a durable epoxy-phenolic coating to provide protection in mildly corrosive coastal environments.
    - b. Coating shall be applied to the aluminum fin stock prior to the fin stamping process to create an inert barrier between the aluminum fin and copper tube.
    - c. Epoxy-phenolic barrier shall minimize galvanic action between dissimilar metals.
  3. Optional Copper-fin evaporator and condenser coils (3 Phase Models Only):
    - a. Shall be constructed of copper fins mechanically bonded to copper tubes and copper tube sheets.
    - b. Galvanized steel tube sheets shall not be acceptable.
    - c. A polymer strip shall prevent coil assembly from contacting the sheet metal coil pan to minimize potential for galvanic corrosion between coil and pan.
  4. Optional E-coated aluminum-fin evaporator and condenser coils (3 Phase Models Only):
    - a. Shall have a flexible epoxy polymer coating uniformly applied to all coil surface areas without material bridging between fins.
    - b. Coating process shall ensure complete coil encapsulation of tubes, fins and headers.
    - c. Color shall be high gloss black with gloss per ASTM D523-89.
    - d. Uniform dry film thickness from 0.8 to 1.2 mil on all surface areas including fin edges.
    - e. Superior hardness characteristics of 2H per ASTM D3363-92A and cross-hatch adhesion of 4B-5B per ASTM D3359-93.
    - f. Impact resistance shall be up to 160 in.-lb (ASTM D2794-93).
    - g. Humidity and water immersion resistance shall be up to minimum 1000 and 250 hours respectively (ASTM D2247-92 and ASTM D870-92).
    - h. Corrosion durability shall be confirmed through testing to be no less than 1000 hours salt spray per ASTM B117-90.
  5. Optional Low NOx Heat Exchanger construction:
    - a. Low NOx reduction shall be provided to reduce nitrous oxide emissions to meet California's Air Quality Management District (SCAQMD) low-NOx emissions requirement of 40 nanograms per joule or less.
    - b. Primary tubes and vestibule plates on low NOx units shall be 409 stainless steel. Other components shall be aluminized steel.
  6. Induced draft combustion motor and blower:
    - a. Shall be a direct-drive, single inlet, forward-curved centrifugal type.
    - b. Shall be made from steel with a corrosion resistant finish.
    - c. Shall have permanently lubricated sealed bearings.
    - d. Shall have inherent thermal overload protection.
    - e. Shall have an automatic reset feature.

J. (23 81 19.13.J.) Refrigerant Components:

1. Refrigerant circuit shall include the following control, safety, and maintenance features:
  - a. Fixed orifice metering system on 036-060 models and TXV on 072 size models shall include a multiple feed distribution system that optimizes coil performance.
  - b. Refrigerant filter drier - Solid core design.
  - c. Service gage connections on suction and discharge lines.
  - d. Pressure gage access through a specially designed access port in the top panel of the unit.
2. There shall be gage line access port in the skin of the rooftop, covered by a black, removable plug.
  - a. The plug shall be easy to remove and replace.
  - b. When the plug is removed, the gage access port shall enable maintenance personnel to route their pressure gage lines.
  - c. This gage access port shall facilitate correct and accurate condenser pressure readings by enabling the reading with the compressor access panel on.
  - d. The plug shall be made of a leak proof, UV-resistant, composite material.
3. Compressors:
  - a. Unit shall use fully hermetic, scroll compressor for each independent refrigeration circuit.
  - b. Compressor motors shall be cooled by refrigerant gas passing through motor windings.
  - c. Compressors shall be internally protected from high discharge temperature conditions.
  - d. Compressors shall be protected from an over-temperature and over-amperage conditions by an internal, motor overload device.
  - e. Compressor shall be factory mounted on rubber grommets.
  - f. Compressor motors shall have internal line break thermal, current overload and high pressure differential protection.
  - g. Crankcase heaters shall not be required for normal operating range, unless required by compressor manufacturer due to refrigerant charge limits.
  - h. Compressor on 036-060 models shall be of a single stage cooling capacity design and 072 models shall be a two stage cooling capacity design.

K. (23 81 19.13.K.) Filter Section:

1. Filters access is specified in the unit cabinet section of this specification.

2. Filters shall be held in place by a pivoting filter tray, facilitating easy removal and installation.
3. Shall consist of factory installed, low velocity, throw-away 2-in. thick fiberglass filters.
4. Filters shall be standard, commercially available sizes.
5. Only one size filter per unit is allowed.

L. (23 81 19.13.L.) Evaporator Fan and Motor with X-Vane™ Fan Technology:

1. Direct Drive Evaporator fan motor:
  - a. Shall be a ECM motor design.
  - b. Shall have permanently lubricated bearings.
  - c. Shall have inherent automatic-reset thermal overload protection.
  - d. Shall have slow ramp up to speed capabilities.
  - e. Shall require no fan/motor belts for operation, adjustments and or initial fan speed set up.
  - f. Fan DC voltage set up on Unit Control Board can eliminate the need of removal of blower access door, required on conventional belt drive systems.
  - g. Shall be internally protected from electrical phase reversal and loss.

2. Evaporator Fan:

- a. Shall be easily set with dedicated selection switch and adjustment pot on unit control board.
- b. On sizes 036-060 single speed indoor fan operation provided and on 072 size model with two stage cooling capacity control, the indoor fan speed is automatically controlled to meet the code-compliant 66% low fan speed and 100% at full fan speed operation.
- c. Blower fan shall be a Vane Axial fan design with 75% less moving parts than a conventional belt drive system.
- d. Shall be constructed of a cast aluminum stator and high impact composite material on rotor and air inlet casing.
- e. Shall be a patented / pending design with a corrosion resistant material and dynamically balanced.
- f. Shall have slow ramp up to speed capabilities to help reduce sound and comfort issues typically associated with single speed belt drive systems.
- g. Shall be a slide out design with two screw removal.

3. Shall include an easily accessible unit Control Board to conveniently and safely provide connection points for vital control functions such as: smoke detectors, phase monitor, gas controller, economizer, thermostat, and low and high pressure switches. Controller shall also

## Guide specifications (cont)

provide an intuitive means to adjust the indoor fan speed through a simple switch and pot adjustment design.

### M. (23 81 19.13.M.) Condenser Fans and Motors:

1. Condenser fan motors:
  - a. Shall be a totally enclosed motor.
  - b. Shall use permanently lubricated bearings.
  - c. Shall have inherent thermal overload protection with an automatic reset feature.
  - d. Shall use a shaft-down design on all sizes.
2. Condenser Fans:
  - a. Shall be a direct-driven propeller type fan constructed of high impact composite material.
  - b. Shall have high impact composite blades completely formed into one piece without blade fasteners or connectors and shall be dynamically balanced.

### N. (23 81 19.13.N.) Special Features Options and Accessories:

1. Integrated EconoMi\$er® IV and EconoMi\$er X low leak rate models. (EconoMi\$er IV and X are factory-installed on 036-060 models. EconoMi\$er X are factory-installed on 072 models. All are field-installed on all 3 and 1 phase models):
  - a. Integrated, gear driven opposing modulating blade design type capable of simultaneous economizer and compressor operation.
  - b. Independent modules for vertical or horizontal return configuration shall be available. Vertical return modules shall be available as a factory installed option.
  - c. Damper blades shall be galvanized steel with composite gears. Plastic or composite blades on intake or return shall not be acceptable.
  - d. Shall include all hardware and controls to provide free cooling with outdoor air when temperature and/or humidity are below setpoints.
  - e. Shall be equipped with gear driven dampers for both the outdoor ventilation air and the return air for positive air stream control.
  - f. Standard leak rate shall be equipped with dampers not to exceed 2% leakage at 1 in. wg pressure differential.
  - g. Economizer controller on EconoMi\$er IV models shall be Honeywell W7212 that provides:
    - 1) Combined minimum and DCV maximum damper position potentiometers with compressor staging relay.
    - 2) Functions with solid-state analog enthalpy or dry bulb changeover control sensing.

- 3) LED indicators for: when free cooling is available, when module is in DCV mode, when exhaust fan contact is closed.

### h. Economizer controller on EconoMi\$er X models shall be the Honeywell W7220 that provides:

- 1) 2-line LCD interface screen for setup, configuration and troubleshooting.
- 2) On-board Fault Detection and Diagnostics (FDD) that senses and alerts when the economizer is not operating properly, per California Title 24, ASHRAE 90.1 and IECC<sup>1</sup>.
- 3) Sensor failure loss of communication identification.
- 4) Automatic sensor detection.
- 5) Capabilities for use with multiple-speed or single speed indoor fan systems.
- 6) Utilize digital sensors: Dry bulb and Enthalpy.
  - i. Shall be capable of introducing up to 100% outdoor air.
  - j. Shall be equipped with a barometric relief damper capable of relieving up to 100% return air and contain seals that meet ASHRAE 90.1 requirements.
  - k. Shall be designed to close damper(s) during loss-of-power situations with spring return built into motor.
  - l. Dry bulb outdoor air temperature sensor shall be provided as standard. Enthalpy sensor is also available on factory-installed economizers only. Outdoor air sensor setpoint shall be adjustable and shall range from 40°F to 100°F (4°C to 38°C). Additional sensor options shall be available as accessories.
  - m. The economizer controller shall also provide control of an accessory power exhaust unit function. Factory set at 100%, with a range of 0% to 100%.
  - n. The economizer shall maintain minimum airflow into the building during occupied period and provide design ventilation rate for full occupancy.
  - o. Dampers shall be completely closed when the unit is in the unoccupied mode.
  - p. Economizer controller shall accept a 2 to 10 Vdc CO<sub>2</sub> sensor input for IAQ/DCV control. In this mode, dampers shall modulate the outdoor air damper to provide ventilation based on the sensor input.
  - q. Compressor lockout temperature on W7220 control is adjustable from -45°F to 80°F (-43°C to 27°C), set at a factory

---

<sup>1</sup>IECC is a registered trademark of the International Code Council, Inc.

- default of 32°F (0°C). W7212 control opens at 35°F (2°C) and closes at 50°F (10°C).
- r. Actuator shall be direct coupled to economizer gear. No linkage arms or control rods shall be acceptable.
  - s. Economizer controller shall provide indications when in free cooling mode, in the DCV mode, or the exhaust fan contact is closed.
2. Integrated EconoMi\$er X Ultra Low Leak rate models. (Factory-installed on 3 phase models only. Field-installed on all 3 and 1 phase models):
- a. Integrated, gear driven opposing modulating blade design type capable of simultaneous economizer and compressor operation.
  - b. Independent modules for vertical or horizontal return configuration shall be available. Vertical return modules shall be available as a factory installed option.
  - c. Damper blades shall be galvanized steel with composite gears. Plastic or composite blades on intake or return shall not be acceptable.
  - d. Shall include all hardware and controls to provide free cooling with outdoor air when temperature and/or humidity are below setpoints.
  - e. Shall be equipped with gear driven dampers for both the outdoor ventilation air and the return air for positive air stream control.
  - f. Ultra Low Leak design meets California Title 24 section 140.4 and ASHRAE 90.1 requirements for 4 cfm per sq.ft on the outside air dampers and 10 cfm per sq. ft on the return dampers.
  - g. Economizer controller on EconoMi\$er X models shall be the Honeywell W7220 that provides:
    - 1) 2-line LCD interface screen for setup, configuration and troubleshooting.
    - 2) On-board Fault Detection and Diagnostics (FDD) that senses and alerts when the economizer is not operating properly, per California Title 24, ASHRAE 90.1 and IECC.
    - 3) Sensor failure loss of communication identification.
    - 4) Automatic sensor detection.
    - 5) Capabilities for use with multiple-speed indoor fan systems.
    - 6) Utilize digital sensors: Dry bulb and Enthalpy.
  - h. Shall be capable of introducing up to 100% outdoor air.
  - i. Shall be equipped with a barometric relief damper capable of relieving up to 100% return air and contain seals that meet ASHRAE 90.1 requirements.
  - j. Shall be designed to close damper(s) during loss-of-power situations with spring return built into motor.
  - k. Dry bulb outdoor air temperature sensor shall be provided as standard. Enthalpy sensor is also available on factory-installed economizers only. Outdoor air sensor setpoint shall be adjustable and shall range from 40°F to 100°F (4°C to 38°C). Additional sensor options shall be available as accessories.
  - l. The economizer controller shall also provide control of an accessory power exhaust unit function. Factory set at 100%, with a range of 0% to 100%.
  - m. The economizer shall maintain minimum airflow into the building during occupied period and provide design ventilation rate for full occupancy.
  - n. Dampers shall be completely closed when the unit is in the unoccupied mode.
  - o. Economizer controller shall accept a 2 to 10 vdc CO<sub>2</sub> sensor input for IAQ/DCV control. In this mode, dampers shall modulate the outdoor air damper to provide ventilation based on the sensor input.
  - p. Compressor lockout temperature on W7220 control is adjustable from -45°F to 80°F (-43°C to 27°C), set at a factory default of 32°F (0°C). W7212 control opens at 35°F (2°C) and closes at 50°F (10°C).
  - q. Actuator shall be direct coupled to economizer gear. No linkage arms or control rods shall be acceptable.
  - r. Economizer controller shall provide indications when in free cooling mode, in the DCV mode, or the exhaust fan contact is closed.
3. Two-Position Damper (Factory-installed on 3-Phase 036-060 Models Only. Field-installed on all 3 and 1 Phase Models):
- a. Damper shall be a Two-Position Damper. Damper travel shall be from the full closed position to the field adjustable %-open setpoint.
  - b. Damper shall include adjustable damper travel from 25% to 100% (full open).
  - c. Damper shall include single or dual blade, gear driven dampers and actuator motor.
  - d. Actuator shall be direct coupled to damper gear. No linkage arms or control rods shall be acceptable.
  - e. Damper will admit up to 100% outdoor air for applicable rooftop units.
  - f. Damper shall close upon indoor (evaporator) fan shutoff and/or loss of power.

## Guide specifications (cont)

- g. The damper actuator shall plug into the rooftop unit's wiring harness plug. No hard wiring shall be required.
- h. Outside air hood shall include aluminum water entrainment filter.
- 4. Manual damper (Field-installed only):
  - a. Manual damper package shall consist of damper, air inlet screen, and rain hood which can be preset to admit up to 25 or 50% outdoor air for year round ventilation.
- 5. Hot Gas Re-Heat Dehumidification System (3 Phase Models Only):
  - a. The Hot Gas Re-Heat Adaptive Dehumidification System shall be factory installed and shall provide greater dehumidification of the occupied space by two modes of dehumidification operations in addition to its normal design cooling mode:
    - 1) Subcooling mode further sub cools the hot liquid refrigerant leaving the condenser coil when both temperature and humidity in the space are not satisfied.
    - 2) Hot gas reheat mode shall mix a portion of the hot gas from the discharge of the compressor with the hot liquid refrigerant leaving the condenser coil to create a two-phase heat transfer in the system, resulting in a neutral leaving air temperature when only humidity in the space is not satisfied.
    - 3) Includes low ambient controller.
- 6. Low Ambient Control Package:
  - a. Controller shall control coil head pressure by condenser fan speed modulation or condenser fan cycling and wind baffles.
  - b. Shall consist of solid-state control and condenser coil temperature sensor to maintain condensing temperature between 90°F (32°C) and 110°F (43°C) at outdoor ambient temperatures down to -20°F (-29°C).
- 7. Propane Conversion Kit:
  - a. Package shall contain all the necessary hardware and instructions to convert a standard natural gas unit for use with liquefied propane, up to 2000 ft (610m) elevation.
  - b. Additional accessory kits may be required for applications above 2000 ft (610m) elevation.
- 8. Flue Shield:
  - a. Flue shield shall provide protection from the hot sides of the gas flue hood.
- 9. Condenser Coil Hail Guard Assembly (Factory-installed on 3 Phase Models Only. Field-installed on all 3 and 1 Phase Models):
  - a. Shall protect against damage from hail.
  - b. Shall be either hood style or louvered.
- 10. Unit-Mounted, Non-Fused Disconnect Switch (Available on units with MOCPs of 80 amps or less):
  - a. Switch shall be factory installed, internally mounted.
  - b. National Electric Code (NEC) and UL approved non-fused switch shall provide unit power shutoff.
  - c. Shall be accessible from outside the unit.
  - d. Shall provide local shutdown and lockout capability.
  - e. Sized only for the unit as ordered from the factory. Does not accommodate field-installed devices.
- 11. Convenience Outlet:
  - a. Powered convenience outlet. (3 Phase Models Only):
    - 1) Outlet shall be powered from main line power to the rooftop unit.
    - 2) Outlet shall be powered from line side or load side of disconnect by installing contractor, as required by code. If outlet is powered from load side of disconnect, unit electrical ratings shall be UL certified and rated for additional outlet amperage.
    - 3) Outlet shall be factory-installed and internally mounted with easily accessible 115-v female receptacle.
    - 4) Outlet shall include 15 amp GFI receptacles with independent fuse protection.
    - 5) Voltage required to operate convenience outlet shall be provided by a factory installed step-down transformer.
    - 6) Outlet shall be accessible from outside the unit.
    - 7) Outlet shall include a field installed "Wet in Use" cover.
  - b. Factory-Installed non-powered convenience outlet:
    - 1) Outlet shall be powered from a separate 115/120v power source.
    - 2) A transformer shall not be included.
    - 3) Outlet shall be factory-installed and internally mounted with easily accessible 115-v female receptacle.
    - 4) Outlet shall include 15 amp GFI receptacles with independent fuse protection.
    - 5) Outlet shall be accessible from outside the unit.
    - 6) Outlet shall include a field installed "Wet in Use" cover.
  - c. Field-Installed non-powered convenience outlet:
    - 1) Outlet shall be powered from a separate 115/120v power source.
    - 2) A transformer shall not be included.

- 3) Outlet shall be field-installed and internally mounted with easily accessible 115-v female receptacle.
  - 4) Outlet shall include 20 amp GFI receptacles. This kit provides a flexible installation method which allows code compliance for height requirements of the GFCI outlet from the finished roof surface as well as the capability to relocate the outlet to a more convenient location.
  - 5) Outlet shall be accessible from outside the unit.
  - 6) Outlet shall include a field installed "Wet in Use" cover.
12. Flue Discharge Deflector:
    - a. Flue discharge deflector shall direct unit exhaust vertically instead of horizontally.
    - b. Deflector shall be defined as a "natural draft" device by the National Fuel and Gas (NFG) code.
  13. Thru-the-Base Connectors:
    - a. Kits shall provide connectors to permit gas and electrical connections to be brought to the unit through the unit basepan.
    - b. Minimum of four connection locations per unit.
  14. Propeller Power Exhaust:
    - a. Power exhaust shall be used in conjunction with an integrated economizer.
    - b. Independent modules for vertical or horizontal return configurations shall be available.
    - c. Horizontal power exhaust is shall be mounted in return ductwork.
    - d. Power exhaust shall be controlled by economizer controller operation. Exhaust fans shall be energized when dampers open past the 0 to 100% adjustable setpoint on the economizer control.
  15. Roof Curbs (Vertical):
    - a. Full perimeter roof curb with exhaust capability providing separate air streams for energy recovery from the exhaust air without supply air contamination.
    - b. Formed galvanized steel with wood nailer strip and shall be capable of supporting entire unit weight.
    - c. Permits installation and securing of ductwork to curb prior to mounting unit on the curb.
  16. High Altitude Gas Conversion Kit:
    - a. Package shall contain all the necessary hardware and instructions to convert a standard natural gas unit to operate from 2000 to 7000 ft (610 to 2134 m) elevation with natural gas or from 0 to 7000 ft (0 to 2134 m) elevation with liquefied propane.
  17. Outdoor Air Enthalpy Sensor:
    - a. The outdoor air enthalpy sensor shall be used to provide single enthalpy control. When used in conjunction with a return air enthalpy sensor, the unit will provide differential enthalpy control. The sensor allows the unit to determine if outside air is suitable for free cooling.
  18. Return Air Enthalpy Sensor:
    - a. The return air enthalpy sensor shall be used in conjunction with an outdoor air enthalpy sensor to provide differential enthalpy control.
  19. Indoor Air Quality (CO<sub>2</sub>) Sensor:
    - a. Shall be able to provide demand ventilation indoor air quality (IAQ) control.
    - b. The IAQ sensor shall be available in duct mount, wall mount, or wall mount with LED display. The setpoint shall have adjustment capability.
  20. Smoke detectors (factory-installed only):
    - a. Shall be a Four-Wire Controller and Detector.
    - b. Shall be environmental compensated with differential sensing for reliable, stable, and drift-free sensitivity.
    - c. Shall use magnet-activated test/reset sensor switches.
    - d. Shall have tool-less connection terminal access.
    - e. Shall have a recessed momentary switch for testing and resetting the detector.
    - f. Controller shall include:
      - 1) One set of normally open alarm initiation contacts for connection to an initiating device circuit on a fire alarm control panel.
      - 2) Two Form-C auxiliary alarm relays for interface with rooftop unit or other equipment.
      - 3) One Form-C supervision (trouble) relay to control the operation of the Trouble LED on a remote test/reset station.
      - 4) Capable of direct connection to two individual detector modules.
      - 5) Can be wired to up to 14 other duct smoke detectors for multiple fan shut-down applications.
  21. Winter Start Kit:
    - a. Shall contain a bypass device around the low pressure switch.
    - b. Shall be required when mechanical cooling is required down to 25°F (-4°C).
    - c. Shall not be required to operate on an economizer when below an outdoor ambient of 40°F (4°C).

## Guide specifications (cont)

22. Time Guard:
  - a. Shall prevent compressor short-cycling by providing a 5-minute delay ( $\pm 2$  minutes) before restarting a compressor after shut-down for any reason.
  - b. One device shall be required per compressor.
23. Hinged Access Panels:
  - a. Shall provide easy access through integrated quarter turn latches.
  - b. Shall be on major panels of: filter, control box, fan motor, and compressor.
24. Condensate overflow switch:
  - a. This sensor and related controller monitors the condensate level in the drain pan and shuts down compression operation when overflow conditions occur. It includes:
    - 1) Indicator light — solid red (more than 10 seconds on water contact – compressors disabled), blinking red (sensor disconnected).
    - 2) 10 second delay to break — eliminates nuisance trips from splashing or waves in pan (sensor needs 10 seconds of constant water contact before tripping).
- 3) Disables the compressor(s) operation when condensate plug is detected, but still allows fans to run for Economizer.
25. Phase Monitor Control:
  - a. Shall monitor the sequence of three phase electrical system to provide a phase reversal protection.
  - b. Shall monitor the three phase voltage inputs to provide a phase loss protection for the three phase device.
  - c. Will work on either a Delta or Wye power connection.
26. Horn/Strobe Annunciator:
  - a. Provides an audible/visual signaling device for use with factory-installed option or field installed accessory smoke detectors.
    - 1) Requires installation of a field-supplied 24-v transformer suitable for 4.2 VA (AC) or 3.0 VA (DC) per horn/strobe accessory.
    - 2) Requires field-supplied electrical box, North American 1-gang box, 2-in. (51 mm) x 4-in. (102 mm).
    - 3) Shall have a clear colored lens.

Note about this specification:

This specification is in the "Masterformat" as published by the Construction Specification Institute. Please feel free to copy this specification directly into your building spec.

## **Cooling Only/Electric Heat Packaged Rooftop**

### **HVAC Guide Specifications**

Size Range: **3 to 6 Nominal Tons**

ICP Model Number: **RAV036-072**

### **Part 1 — (23 06 80) Schedules for Decentralized HVAC Equipment**

1.01 (23 06 80.13) Decentralized Unitary HVAC Equipment Schedule:

A. (23 06 80.13.A.) Rooftop unit (RTU) schedule:

1. Schedule is per the project specification requirements.

### **Part 2 — (23 07 16) HVAC equipment insulation**

2.01 (23 07 16.13) Decentralized, Rooftop Units:

A. (23 07 16.13.A.) Evaporator fan compartment:

1. Interior cabinet surfaces shall be insulated with a minimum 1/2-in. thick, minimum 1 1/2-lb density, flexible fiberglass insulation bonded with a phenolic binder, neoprene coated on the air side.
2. Insulation and adhesive shall meet NFPA 90A requirements for flame spread and smoke generation.

B. (23 07 16.13.B.) Electric Heat Compartment:

1. Aluminum foil-faced fiberglass insulation shall be used.
2. Insulation and adhesive shall meet NFPA 90A requirements for flame spread and smoke generation.

### **Part 3 — (23 09 13) Instrumentation and control devices for HVAC**

3.01 (23 09 13.23) Sensors and Transmitters:

A. (23 09 13.23.A.) Thermostats:

1. Thermostat must
  - a. energize both "W" and "G" when calling for heat.
  - b. have capability to energize 1 or 2 stages of cooling, and 2 different stages of heating.
  - c. include capability for occupancy scheduling.

### **Part 4 — (23 09 33) Electric and Electronic Control System for HVAC**

4.01 (23 09 33.13) Decentralized, Rooftop Units:

A. (23 09 33.13.A.) General:

1. Shall be complete with self-contained low-voltage control circuit protected by a resettable circuit breaker on the 24-v transformer side. Transformer shall have 75VA capability.
2. Shall utilize color-coded wiring.
3. Shall include a Unit Control Board to conveniently and safely provide connection points for vital control functions such as: smoke

detectors, phase monitor, economizer, thermostat, and low and high pressure switches. Controller shall also provide an intuitive means to adjust the indoor fan speed through a simple switch and pot adjustment design.

4. Unit shall include a minimum of one 8-pin screw terminal connection board for connection of control wiring.

B. (23 09 33.13.B.) Safeties:

1. Compressor over-temperature, over-current. High internal pressure differential.
2. Low pressure switch:
  - a. Low pressure switch shall use different color wire than the high pressure switch. The purpose is to assist the installer and service technician to correctly wire and or troubleshoot the rooftop unit.
3. High pressure switch:
  - a. High pressure switch shall use different color wire than the low pressure switch. The purpose is to assist the installer and service technician to correctly wire and or troubleshoot the rooftop unit.
4. Automatic reset, motor thermal overload protector.

### **Part 5 — (23 09 93) Sequence of Operations for HVAC Controls**

5.01 (23 09 93.13) Decentralized, Rooftop Units:

A. (23 09 93.13.A.) INSERT SEQUENCE OF OPERATION

### **Part 6 — (23 40 13) Panel Air Filters**

6.01 (23 40 13.13) Decentralized, Rooftop Units:

A. (23 40 13.13.A.) Standard filter section:

1. Shall consist of factory installed, low velocity, disposable 2-in. thick fiberglass filters of commercially available sizes.
2. Unit shall use only one filter size. Multiple sizes are not acceptable.
3. Filters shall be accessible through an access panel with "no-tool" removal as described in the unit cabinet section of this specification (23 81 19.13.G).

### **Part 7 — (23 81 19) Self-Contained Air Conditioners**

7.01 (23 81 19.13) Small-Capacity Self-Contained Air Conditioners:

A. (23 81 19.13.A.) General:

1. Outdoor, rooftop mounted, electrically controlled, heating and cooling unit utilizing a fully hermetic scroll compressor(s) for cooling duty and optional electric heat for heating duty.
2. Factory assembled, single-piece heating and cooling rooftop unit. Contained within the unit enclosure shall be all factory wiring, piping, controls, and special features required prior to field start-up.
3. Unit shall use R-410A refrigerant.

## Guide specifications (cont)

4. Unit shall be installed in accordance with the manufacturer's instructions.
  5. Unit must be selected and installed in compliance with local, state, and federal codes.
- B. (23 81 19.13.B.) Quality Assurance:
1. Unit meets ASHRAE 90.1 minimum efficiency requirements.
  2. Unit shall be rated in accordance with AHRI Standards 210/240 (036-060 sizes) or 340/360 (072 size).
  3. Unit shall be designed to conform to ASHRAE 15.
  4. Unit shall be UL-tested and certified in accordance with ANSI Z21.47 Standards and UL-listed and certified under Canadian standards as a total package for safety requirements.
  5. Insulation and adhesive shall meet NFPA 90A requirements for flame spread and smoke generation.
  6. Unit casing shall be capable of withstanding 500 hour salt spray exposure per ASTM B117 (scribed specimen).
  7. Unit shall be designed in accordance with ISO 9001, and shall be manufactured in a facility registered by ISO 9001:2015.
  8. Roof curb shall be designed to conform to NRCA Standards.
  9. Unit shall be subjected to a completely automated run test on the assembly line. The data for each unit will be stored at the factory, and must be available upon request.
  10. Unit shall be designed in accordance with UL Standard 1995, including tested to withstand rain.
  11. Unit shall be constructed to prevent intrusion of snow and tested to prevent snow intrusion into the control box up to 40 mph.
  12. Unit shake tested to assurance level 1, ASTM D4169 to ensure shipping reliability.
- C. (23 81 19.13.C.) Delivery, Storage, and Handling:
1. Unit shall be stored and handled per manufacturer's recommendations.
  2. Lifted by crane requires either shipping top panel or spreader bars.
  3. Unit shall only be stored or positioned in the upright position.
- D. (23 81 19.13.D.) Project Conditions:
1. As specified in the contract.
- E. (23 81 19.13.E.) Operating Characteristics:
1. Unit shall be capable of starting and running at 115°F (46°C) ambient outdoor temperature, meeting maximum load criteria of AHRI Standard 210/240 or 340/360 at ±10% voltage.
  2. Compressor with standard controls shall be capable of operation down to 40°F (4°C), ambient outdoor temperatures. Accessory winter start kit is necessary if mechanically cooling at ambient temperatures down to 25°F (-4°C).
3. Unit shall discharge supply air vertically or horizontally as shown on contract drawings.
  4. Unit shall be factory configured for vertical supply and return configurations.
  5. Unit shall be field convertible from vertical to horizontal airflow on all models. No special kit required.
  6. Unit shall be capable of mixed operation: vertical supply with horizontal return or horizontal supply with vertical return.
- F. (23 81 19.13.F.) Electrical Requirements:
1. Main power supply voltage, phase, and frequency must match those required by the manufacturer.
- G. (23 81 19.13.G.) Unit Cabinet:
1. Unit cabinet shall be constructed of galvanized steel, and shall be bonderized and coated with a pre-painted baked enamel finish on all externally exposed surfaces.
  2. Unit cabinet exterior paint shall be: film thickness, (dry) 0.003-in. minimum, gloss (per ASTM D523, 60°F/16°C): 60, Hardness: H-2H Pencil hardness.
  3. Evaporator fan compartment interior cabinet insulation shall conform to AHRI Standards 210/240 and or 340/360 minimum exterior sweat criteria. Interior surfaces shall be insulated with a minimum 1/2-in. thick, 1 lb density, flexible fiberglass insulation, neoprene coated on the air side. Aluminum foil-faced fiberglass insulation shall be used in the heat compartment.
  4. Base of unit shall have a minimum of four locations for thru-the-base gas and electrical connections (factory-installed or field-installed), standard.
  5. Base Rail:
    - a. Unit shall have base rails on a minimum of 2 sides.
    - b. Holes shall be provided in the base rails for rigging shackles to facilitate maneuvering and overhead rigging.
    - c. Holes shall be provided in the base rail for moving the rooftop by fork truck.
    - d. Base rail shall be a minimum of 16 gage thickness.
  6. Condensate pan and connections:
    - a. Shall be a sloped condensate drain pan made of a corrosion resistant material.
    - b. Shall comply with ASHRAE Standard 62.
    - c. Shall use a 3/4-in. 14 NPT drain connection, possible either through the bottom or side of the drain pan. Connection shall be made per manufacturer's recommendations.

7. Top panel:
  - a. Shall be a single piece top panel on all sizes.
8. Electrical Connections:
  - a. All unit power wiring shall enter unit cabinet at a single, factory prepared, knockout location.
  - b. Thru-the-base capability:
    - 1) Standard unit shall have a thru-the-base electrical location(s) using a raised, embossed portion of the unit basepan.
    - 2) Optional, factory approved, water-tight connection method must be used for thru-the-base electrical connections.
    - 3) No basepan penetration, other than those authorized by the manufacturer, is permitted.
9. Component access panels (standard):
  - a. Cabinet panels shall be easily removable for servicing.
  - b. Unit shall have one factory installed, tool-less, removable, filter access panel.
  - c. Panels covering control box, indoor fan, indoor fan motor, gas components (where applicable), and compressors shall have molded composite handles.
  - d. Handles shall be UV modified, composite. They shall be permanently attached, and recessed into the panel.
  - e. Screws on the vertical portion of all removable access panel shall engage into heat resistant, molded composite collars.
  - f. Collars shall be removable and easily replaceable using manufacturer recommended parts.
- H. (23 81 19.13.H.) Coils:
  1. Standard Aluminum Fin-Copper Tube Coils:
    - a. Standard evaporator and condenser coils shall have aluminum lanced plate fins mechanically bonded to seamless internally grooved copper tubes with all joints brazed.
    - b. Evaporator coils shall be leak tested to 150 psig, pressure tested to 450 psig, and qualified to UL 1995 burst test at 1775 psig.
    - c. Condenser coils shall be leak tested to 150 psig, pressure tested to 650 psig, and qualified to UL 1995 burst test at 1980 psig.
  2. Optional Pre-coated aluminum-fin condenser coils (3 Phase Models Only):
    - a. Shall have a durable epoxy-phenolic coating to provide protection in mildly corrosive coastal environments.
    - b. Coating shall be applied to the aluminum fin stock prior to the fin stamping process to create an inert barrier between the aluminum fin and copper tube.
    - c. Epoxy-phenolic barrier shall minimize galvanic action between dissimilar metals.
    - d. Corrosion durability of fin stock shall be confirmed through testing to be no less than 1000 hours salt spray per ASTM B117-90.
    - e. Corrosion durability of fin stock shall be confirmed through testing to have no visible corrosion after 48 hour immersion in a room temperature solution of 5% salt, 1% acetic acid.
    - f. Fin stock coating shall pass 2000 hours of the following: one week exposure in the prohesion chamber followed by one week of accelerated ultraviolet light testing. Prohesion chamber: the solution shall contain 3.5% sodium chloride and 0.35% ammonium sulfate. The exposure cycle is one hour of salt fog application at ambient followed by one hour drying at 95°F (35°C).
  3. Optional Copper-fin evaporator and condenser coils (3 Phase Models Only):
    - a. Shall be constructed of copper fins mechanically bonded to copper tubes and copper tube sheets.
    - b. Galvanized steel tube sheets shall not be acceptable.
    - c. A polymer strip shall prevent coil assembly from contacting the sheet metal coil pan to minimize potential for galvanic corrosion between coil and pan.
  4. Optional E-coated aluminum-fin evaporator and condenser coils (3 Phase Models Only):
    - a. Shall have a flexible epoxy polymer coating uniformly applied to all coil surface areas without material bridging between fins.
    - b. Coating process shall ensure complete coil encapsulation of tubes, fins and headers.
    - c. Color shall be high gloss black with gloss per ASTM D523-89.
    - d. Uniform dry film thickness from 0.8 to 1.2 mil on all surface areas including fin edges.
    - e. Superior hardness characteristics of 2H per ASTM D3363-92A and cross-hatch adhesion of 4B-5B per ASTM D3359-93.
    - f. Impact resistance shall be up to 160 in.-lb (ASTM D2794-93).
    - g. Humidity and water immersion resistance shall be up to minimum 1000 and 250 hours respectively (ASTM D2247-92 and ASTM D870-92).
    - h. Corrosion durability shall be confirmed through testing to be no less than 1000 hours salt spray per ASTM B117-90.

# Guide specifications (cont)

## I. (23 81 19.13.I.) Refrigerant Components:

1. Refrigerant circuit shall include the following control, safety, and maintenance features:
  - a. Fixed orifice metering system on 036-060 models and TXV on 072 size models shall include a multiple feed distribution system that optimizes coil performance.
  - b. Refrigerant filter drier - solid core design.
  - c. Service gage connections on suction and discharge lines.
  - d. Pressure gage access through a specially designed access port in the top panel of the unit.
2. There shall be gage line access port in the skin of the rooftop, covered by a black, removable plug.
  - a. The plug shall be easy to remove and replace.
  - b. When the plug is removed, the gage access port shall enable maintenance personnel to route their pressure gage lines.
  - c. This gage access port shall facilitate correct and accurate condenser pressure readings by enabling the reading with the compressor access panel on.
  - d. The plug shall be made of a leak proof, UV-resistant, composite material.
3. Compressors:
  - a. Unit shall use fully hermetic, scroll compressor for each independent refrigeration circuit.
  - b. Compressor motors shall be cooled by refrigerant gas passing through motor windings.
  - c. Compressors shall be internally protected from high discharge temperature conditions.
  - d. Compressors shall be protected from an over-temperature and over-amperage conditions by an internal, motor overload device.
  - e. Compressor shall be factory mounted on rubber grommets.
  - f. Compressor motors shall have internal line break thermal, current overload and high pressure differential protection.
  - g. Crankcase heaters shall not be required for normal operating range, unless required by compressor manufacturer due to refrigerant charge limits.
  - h. Compressor on 036-060 models shall be of a single stage cooling capacity design and 072 models shall be a two stage cooling capacity design.

## J. (23 81 19.13.J.) Filter Section:

1. Filters access is specified in the unit cabinet section of this specification.

2. Filters shall be held in place by a pivoting filter tray, facilitating easy removal and installation.
3. Shall consist of factory installed, low velocity, throw-away 2-in. thick fiberglass filters.
4. Filters shall be standard, commercially available sizes.
5. Only one size filter per unit is allowed.

## K. (23 81 19.13.K.) Evaporator Fan and Motor with X-Vane™ Fan Technology:

1. Direct Drive Evaporator fan motor:
  - a. Shall be a ECM motor design.
  - b. Shall have permanently lubricated bearings.
  - c. Shall have inherent automatic-reset thermal overload protection.
  - d. Shall have slow ramp up to speed capabilities.
  - e. Shall require no fan/motor belts for operation, adjustments and or initial fan speed set up.
  - f. Fan DC voltage set up on Unit Control Board can eliminate the need of removal of blower access door, required on conventional belt drive systems.
  - g. Shall be internally protected from electrical phase reversal and loss.
2. Evaporator Fan:
  - a. Shall be easily set with dedicated selection switch and adjustment pot on unit control board.
  - b. On sizes 036-060 single speed indoor fan operation provided and on 072 size model with two stage cooling capacity control, the indoor fan speed is automatically controlled to meet the code-compliant 66% low fan speed and 100% at full fan speed operation.
  - c. Blower fan shall be a Vane Axial fan design with 75% less moving parts than a conventional belt drive system.
  - d. Shall be constructed of a cast aluminum stator and high impact composite material on rotor and air inlet casing.
  - e. Shall be a patented / pending design with a corrosion resistant material and dynamically balanced.
  - f. Shall have slow ramp up to speed capabilities to help reduce sound and comfort issues typically associated with single speed belt drive systems.
  - g. Shall be a slide out design with two screw removal.
3. Shall include an easily accessible unit Control Board to conveniently and safely provide connection points for vital control functions such as: smoke detectors, phase monitor, gas controller, economizer, thermostat, and low and high pressure switches. Controller shall also provide an intuitive means to adjust the indoor

fan speed through a simple switch and pot adjustment design.

L. (23 81 19.13.L.) Condenser Fans and Motors:

1. Condenser fan motors:
  - a. Shall be a totally enclosed motor.
  - b. Shall use permanently lubricated bearings.
  - c. Shall have inherent thermal overload protection with an automatic reset feature.
  - d. Shall use a shaft-down design on all sizes.

2. Condenser Fans:

- a. Shall be a direct-driven propeller type fan constructed of high impact composite material.
- b. Shall have high impact composite blades completely formed into one piece without blade fasteners or connectors and shall be dynamically balanced.

M. (23 81 19.13.M.) Special Features Options and Accessories:

1. Integrated EconoMi\$er® IV and EconoMi\$er X low leak rate models. (EconoMi\$er IV and X are factory-installed on 036-060 models. EconoMi\$er X are factory-installed on 072 models. All are field-installed on all 3 and 1 phase models):

- a. Integrated, gear driven opposing modulating blade design type capable of simultaneous economizer and compressor operation.
- b. Independent modules for vertical or horizontal return configuration shall be available. Vertical return modules shall be available as a factory installed option.
- c. Damper blades shall be galvanized steel with composite gears. Plastic or composite blades on intake or return shall not be acceptable.
- d. Shall include all hardware and controls to provide free cooling with outdoor air when temperature and/or humidity are below setpoints.
- e. Shall be equipped with gear driven dampers for both the outdoor ventilation air and the return air for positive air stream control.
- f. Standard leak rate shall be equipped with dampers not to exceed 2% leakage at 1 in. wg pressure differential.
- g. Economizer controller on EconoMi\$er IV models shall be Honeywell W7212 that provides:
  - 1) Combined minimum and DCV maximum damper position potentiometers with compressor staging relay.
  - 2) Functions with solid-state analog enthalpy or dry bulb changeover control sensing.
  - 3) Contain LED indicates for: when free cooling is available, when module is in

DCV mode, when exhaust fan contact is closed.

- h. Economizer controller on EconoMi\$er X models shall be the Honeywell W7220 that provides:

- 1) 2-line LCD interface screen for setup, configuration and troubleshooting.
- 2) On-board Fault Detection and Diagnostics (FDD) that senses and alerts when the economizer is not operating properly, per California Title 24, ASHRAE 90.1 and IECC<sup>1</sup>.
- 3) Sensor failure loss of communication identification.
- 4) Automatic sensor detection.
- 5) Capabilities for use with multiple-speed or single speed indoor fan systems.
- 6) Utilize digital sensors: Dry bulb and Enthalpy.

- i. Shall be capable of introducing up to 100% outdoor air.
- j. Shall be equipped with a barometric relief damper capable of relieving up to 100% return air and contain seals that meet ASHRAE 90.1 requirements.
- k. Shall be designed to close damper(s) during loss-of-power situations with spring return built into motor.
- l. Dry bulb outdoor air temperature sensor shall be provided as standard. Enthalpy sensor is also available on factory installed only. Outdoor air sensor setpoint shall be adjustable and shall range from 40°F to 100°F (4°C to 38°C). Additional sensor options shall be available as accessories.
- m. The economizer controller shall also provide control of an accessory power exhaust unit function. Factory set at 100%, with a range of 0% to 100%.
- n. The economizer shall maintain minimum airflow into the building during occupied period and provide design ventilation rate for full occupancy.
- o. Dampers shall be completely closed when the unit is in the unoccupied mode.
- p. Economizer controller shall accept a 2 to 10 vdc CO<sub>2</sub> sensor input for IAQ/DCV control. In this mode, dampers shall modulate the outdoor air damper to provide ventilation based on the sensor input.
- q. Compressor lockout temperature on W7220 control is adjustable from -45°F to 80°F (-43°C to 27°C), set at a factory default of 32°F (0°C). W7212 control opens at 35°F (2°C) and closes at 50°F (10°C).

---

<sup>1</sup>IECC is a registered trademark of the International Code Council, Inc.

## Guide specifications (cont)

- r. Actuator shall be direct coupled to economizer gear. No linkage arms or control rods shall be acceptable.
  - s. Economizer controller shall provide indications when in free cooling mode, in the DCV mode, or the exhaust fan contact is closed.
2. Integrated EconoMi\$er X Ultra Low Leak rate models. (Factory-installed on 3 phase models only. Field-installed on all 3 and 1 phase models):
- a. Integrated, gear driven opposing modulating blade design type capable of simultaneous economizer and compressor operation.
  - b. Independent modules for vertical or horizontal return configuration shall be available. Vertical return modules shall be available as a factory-installed option.
  - c. Damper blades shall be galvanized steel with composite gears. Plastic or composite blades on intake or return shall not be acceptable.
  - d. Shall include all hardware and controls to provide free cooling with outdoor air when temperature and/or humidity are below setpoints.
  - e. Shall be equipped with gear driven dampers for both the outdoor ventilation air and the return air for positive air stream control.
  - f. Ultra Low Leak design meets California Title 24 section 140.4 and ASHRAE 90.1 requirements for 4 cfm per sq.ft. on the outside air dampers and 10 cfm per sq. ft. on the return dampers.
  - g. Economizer controller on EconoMi\$er X models shall be the Honeywell W7220 that provides:
    - 1) 2-line LCD interface screen for setup, configuration and troubleshooting.
    - 2) On-board Fault Detection and Diagnostics (FDD) that senses and alerts when the economizer is not operating properly, per California Title 24, ASHRAE 90.1 and IECC.
    - 3) Sensor failure loss of communication identification.
    - 4) Automatic sensor detection.
    - 5) Capabilities for use with multiple-speed indoor fan systems.
    - 6) Utilize digital sensors: Dry bulb and Enthalpy.
  - h. Shall be capable of introducing up to 100% outdoor air.
  - i. Shall be equipped with a barometric relief damper capable of relieving up to 100% return air and contain seals that meet ASHRAE 90.1 requirements.
  - j. Shall be designed to close damper(s) during loss-of-power situations with spring return built into motor.
- k. Dry bulb outdoor air temperature sensor shall be provided as standard. Enthalpy sensor is also available on factory installed only. Outdoor air sensor setpoint shall be adjustable and shall range from 40°F to 100°F (4°C to 38°C). Additional sensor options shall be available as accessories.
- l. The economizer controller shall also provide control of an accessory power exhaust unit function. Factory set at 100%, with a range of 0% to 100%.
- m. The economizer shall maintain minimum airflow into the building during occupied period and provide design ventilation rate for full occupancy.
- n. Dampers shall be completely closed when the unit is in the unoccupied mode.
- o. Economizer controller shall accept a 2 to 10 vdc CO<sub>2</sub> sensor input for IAQ/DCV control. In this mode, dampers shall modulate the outdoor air damper to provide ventilation based on the sensor input.
- p. Compressor lockout temperature on W7220 control is adjustable from -45°F to 80°F (-43°C to 27°C), set at a factory default of 32°F (0°C). W7212 control opens at 35°F (2°C) and closes at 50°F (10°C).
- q. Actuator shall be direct coupled to economizer gear. No linkage arms or control rods shall be acceptable.
- r. Economizer controller shall provide indications when in free cooling mode, in the DCV mode, or the exhaust fan contact is closed.
3. Two-Position Damper (Factory-installed on 3 Phase 036-060 Models Only. Field-installed on all 3 and 1 Phase Models):
- a. Damper shall be a Two-Position Damper. Damper travel shall be from the full closed position to the field adjustable %-open setpoint.
  - b. Damper shall include adjustable damper travel from 25% to 100% (full open).
  - c. Damper shall include single or dual blade, gear driven dampers and actuator motor.
  - d. Actuator shall be direct coupled to damper gear. No linkage arms or control rods shall be acceptable.
  - e. Damper will admit up to 100% outdoor air for applicable rooftop units.
  - f. Damper shall close upon indoor (evaporator) fan shutoff and/or loss of power.
  - g. The damper actuator shall plug into the rooftop unit's wiring harness plug. No hard wiring shall be required.
  - h. Outside air hood shall include aluminum water entrainment filter.

4. Manual damper (field-installed only):
  - a. Manual damper package shall consist of damper, air inlet screen, and rain hood which can be preset to admit up to 25% or 50% outdoor air for year round ventilation.
5. Hot Gas Re-Heat Dehumidification System (3 Phase Models Only):
  - a. The Hot Gas Re-Heat Dehumidification System shall be factory installed and shall provide greater dehumidification of the occupied space by two modes of dehumidification operations in addition to its normal design cooling mode:
    - 1) Subcooling mode further sub cools the hot liquid refrigerant leaving the condenser coil when both temperature and humidity in the space are not satisfied.
    - 2) Hot gas reheat mode shall mix a portion of the hot gas from the discharge of the compressor with the hot liquid refrigerant leaving the condenser coil to create a two-phase heat transfer in the system, resulting in a neutral leaving air temperature when only humidity in the space is not satisfied.
    - 3) Includes low ambient controller.
6. Low Ambient Control Package:
  - a. Controller shall control coil head pressure by condenser fan speed modulation or condenser fan cycling and wind baffles.
  - b. Shall consist of solid-state control and condenser coil temperature sensor to maintain condensing temperature between 90°F (32°C) and 110°F (43°C) at outdoor ambient temperatures down to -20°F (-29°C).
7. Condenser Coil Hail Guard Assembly (Factory-installed on 3 Phase Models Only. Field-installed on all 3 and 1 Phase Models):
  - a. Shall protect against damage from hail.
  - b. Shall be either hood style or louvered.
8. Unit-Mounted, Non-Fused Disconnect Switch (Available on units with MOCPs of 80 amps or less):
  - a. Switch shall be factory installed, internally mounted.
  - b. National Electric Code (NEC) and UL approved non-fused switch shall provide unit power shutoff.
  - c. Shall be accessible from outside the unit.
  - d. Shall provide local shutdown and lockout capability.
  - e. Sized only for the unit as ordered from the factory. Does not accommodate field-installed devices.
9. Convenience Outlet:
  - a. Powered convenience outlet. (3 Phase Models Only):
    - 1) Outlet shall be powered from main line power to the rooftop unit.
    - 2) Outlet shall be powered from line side or load side of disconnect by installing contractor, as required by code. If outlet is powered from load side of disconnect, unit electrical ratings shall be UL certified and rated for additional outlet amperage.
    - 3) Outlet shall be factory-installed and internally mounted with easily accessible 115-v female receptacle.
    - 4) Outlet shall include 15 amp GFI receptacles with independent fuse protection.
    - 5) Voltage required to operate convenience outlet shall be provided by a factory installed step-down transformer.
    - 6) Outlet shall be accessible from outside the unit.
    - 7) Outlet shall include a field installed "Wet in Use" cover.
  - b. Factory-installed non-powered convenience outlet:
    - 1) Outlet shall be powered from a separate 115/120v power source.
    - 2) A transformer shall not be included.
    - 3) Outlet shall be factory-installed and internally mounted with easily accessible 115-v female receptacle.
    - 4) Outlet shall include 15 amp GFI receptacles with independent fuse protection.
    - 5) Outlet shall be accessible from outside the unit.
    - 6) Outlet shall include a field installed "Wet in Use" cover.
  - c. Field-installed non-powered convenience outlet:
    - 1) Outlet shall be powered from a separate 115/120v power source.
    - 2) A transformer shall not be included.
    - 3) Outlet shall be field-installed and internally mounted with easily accessible 115-v female receptacle.
    - 4) Outlet shall include 20 amp GFI receptacles. This kit provides a flexible installation method which allows code compliance for height requirements of the GFCI outlet from the finished roof surface as well as the capability to relocate the outlet to a more convenient location.
    - 5) Outlet shall be accessible from outside the unit.
    - 6) Outlet shall include a field installed "Wet in Use" cover.

# Guide specifications (cont)

10. Thru-the-Base Connectors:
  - a. Kits shall provide connectors to permit gas and electrical connections to be brought to the unit through the unit basepan.
  - b. Minimum of four connection locations per unit.
11. Propeller Power Exhaust:
  - a. Power exhaust shall be used in conjunction with an integrated economizer.
  - b. Independent modules for vertical or horizontal return configurations shall be available.
  - c. Horizontal power exhaust is shall be mounted in return ductwork.
  - d. Power exhaust shall be controlled by economizer controller operation. Exhaust fans shall be energized when dampers open past the 0 to 100% adjustable setpoint on the economizer control.
12. Roof Curbs (Vertical):
  - a. Full perimeter roof curb with exhaust capability providing separate air streams for energy recovery from the exhaust air without supply air contamination.
  - b. Formed galvanized steel with wood nailer strip and shall be capable of supporting entire unit weight.
  - c. Permits installation and securing of ductwork to curb prior to mounting unit on the curb.
13. Outdoor Air Enthalpy Sensor:
  - a. The outdoor air enthalpy sensor shall be used to provide single enthalpy control. When used in conjunction with a return air enthalpy sensor, the unit will provide differential enthalpy control. The sensor allows the unit to determine if outside air is suitable for free cooling.
14. Return Air Enthalpy Sensor:
  - a. The return air enthalpy sensor shall be used in conjunction with an outdoor air enthalpy sensor to provide differential enthalpy control.
15. Indoor Air Quality (CO<sub>2</sub>) Sensor:
  - a. Shall be able to provide demand ventilation indoor air quality (IAQ) control.
  - b. The IAQ sensor shall be available in duct mount, wall mount, or wall mount with LED display. The setpoint shall have adjustment capability.
16. Smoke detectors (factory-installed only):
  - a. Shall be a four-wire controller and detector.
  - b. Shall be environmental compensated with differential sensing for reliable, stable, and drift-free sensitivity.
  - c. Shall use magnet-activated test/reset sensor switches.
  - d. Shall have tool-less connection terminal access.
  - e. Shall have a recessed momentary switch for testing and resetting the detector.
  - f. Controller shall include:
    - 1) One set of normally open alarm initiation contacts for connection to an initiating device circuit on a fire alarm control panel.
    - 2) Two Form-C auxiliary alarm relays for interface with rooftop unit or other equipment.
    - 3) One Form-C supervision (trouble) relay to control the operation of the Trouble LED on a remote test/reset station.
    - 4) Capable of direct connection to two individual detector modules.
    - 5) Can be wired to up to 14 other duct smoke detectors for multiple fan shutdown applications.
17. Winter Start Kit:
  - a. Shall contain a bypass device around the low pressure switch.
  - b. Shall be required when mechanical cooling is required down to 25°F (-4°C).
  - c. Shall not be required to operate on an economizer when below an outdoor ambient of 40°F (4°C).
18. Time Guard:
  - a. Shall prevent compressor short-cycling by providing a 5 minute delay (±2 minutes) before restarting a compressor after shutdown for any reason.
  - b. One device shall be required per compressor.
19. Hinged Access Panels:
  - a. Shall provide easy access through integrated quarter turn latches.
  - b. Shall be on major panels of: filter, control box, fan motor, and compressor.
20. Condensate overflow switch:
  - a. This sensor and related controller monitors the condensate level in the drain pan and shuts down compression operation when overflow conditions occur. It includes:
    - 1) Indicator light — solid red (more than 10 seconds on water contact — compressors disabled), blinking red (sensor disconnected).
    - 2) 10 second delay to break — eliminates nuisance trips from splashing or waves in pan (sensor needs 10 seconds of constant water contact before tripping).
    - 3) Disables the compressor(s) operation when condensate plug is detected, but still allows fans to run for Economizer.

21. Phase Monitor Control:

- a. Shall monitor the sequence of three phase electrical system to provide a phase reversal protection.
- b. Shall monitor the three phase voltage inputs to provide a phase loss protection for the three phase device.
- c. Will work on either a Delta or Wye power connection.

22. Horn/Strobe Annunciator:

- a. Provides an audible/visual signaling device for use with factory-installed option or field installed accessory smoke detectors.
  - 1) Requires installation of a field-supplied 24-v transformer suitable for 4.2 VA (AC) or 3.0 VA (DC) per horn/strobe accessory.
  - 2) Requires field-supplied electrical box, North American 1-gang box, 2-in. (51 mm) x 4-in. (102 mm).

- 3) Shall have a clear colored lens.

23. Electric Heat:

a. Heating Section:

- 1) Heater element open coil resistance wire, nickel-chrome alloy, 0.29 inches inside diameter, strung through ceramic insulators mounted on metal frame. Coil ends are staked and welded to terminal screw slots.
- 2) Heater assemblies are provided with integral fusing for protection of internal heater circuits not exceeding 48 amps each. Auto reset thermo limit controls, magnetic heater contactors (24 v coil) and terminal block all mounted in electric heater control box (minimum 18 ga galvanized steel) attached to end of heater assembly.

Copyright 2019 International Comfort Products  
Lewisburg, Tennessee 37091 USA  
[www.GoTempstar.com](http://www.GoTempstar.com)