



TECHNICAL GUIDE

MODULAR STANDARD ECM AIR HANDLERS

FOR USE WITH SPLIT-SYSTEM
COOLING AND HEAT PUMPS

**MODELS: ME SERIES - 460 V -
3 PHASE**



Due to continuous product improvement, specifications are subject to change without notice.

Visit us on the web at

www.simplygettingthejobdone.com and
www.colemanac.com

Additional rating information can be found at
www.ahridirectory.org

WARRANTY SUMMARY

Standard 5-year limited parts warranty.

Extended 10-year limited parts warranty when product is registered online within 90 days of purchase for replacement or closing for new home construction.

DESCRIPTION

This unique modular system has the flexibility to handle any application. These versatile ME blowers can be used for upflow, downflow, horizontal left, or horizontal right applications. They can be combined with cased coils to function as a cooling only unit or with a heat pump including electric heat for 3 phase applications. The ME blower and 6HK electric heat kits can be used as stand alone electric furnaces. Using Standard ECM motors, system matches provide higher SEER/HSPF ratings than standard blower models at attractive price points.

FEATURES

COMMON ME AIR HANDLER AND MATCH-UP CM COIL FEATURES

Rigid Case Construction - An interior endoskeleton provides structural support and smooth sides, and locks in insulation.

Powder-Painted - The G30 galvanized steel case provides a coated edge that resists corrosion and rust creep.

Quality Construction - Structural components are made of aluminum or G90 galvanized steel to prevent corrosion.

Improved Insulation Design - Single piece with no external screws to reduce thermal transmission paths to prevent sweating. The foil faced insulation makes cleaning easy.

Case Depth - These models have 20.5" casing, which allows easy access in attics and tight applications.

ME AIR HANDLERS

Factory Sealed - These models achieve 2% or less total airflow leakage rate at duct leakage test conditions in positive and negative pressure for system airflow verification.

Electric Heat Kits - The 6HK series of field installed electric heat kits is available for installation-friendly and easy service applications.

Blowers - All models use direct-drive, standard ECM motors.

CM COILS

MaxAlloy™ Coil - Long life aluminum coils are built to deliver lasting performance, efficiency, and reliability.

Thermostatic Expansion Valve - The TXV is installed using Chatleff mechanical fittings and is easy to install on any MaxAlloy coil without brazing to create an appropriate system match. Some models are available with a factory installed TXV.

Thermoset Drain Pan - Low retention and positive slope for drainage reduces potential mold or contaminants.

Accessories - A full line of matching accessories is available for use with the blower and coils to provide for any type of application.

LIST OF SECTIONS

DESCRIPTION	1
FEATURES	1
NOMENCLATURE	2
DIMENSIONS AND DUCT CONNECTION DIMENSIONS ..	3
DIMENSIONS - ME MODULAR AIR HANDLERS AND CM MULTI-POSITION FULL CASED COILS	3
COOLING CAPACITY	4
PHYSICAL AND ELECTRICAL DATA - COOLING ONLY ..	5
APPLICATION FACTORS - RATED CFM VS. ACTUAL CFM	5
ELECTRICAL DATA - COOLING ONLY	6
ELECTRICAL HEAT - MINIMUM FAN SPEED	6
ELECTRIC HEAT PERFORMANCE DATA: 460-3-60	6
ELECTRICAL DATA FOR SINGLE SOURCE POWER SUPPLY: 460-3-60	7
POWER WIRING - LINE CONNECTIONS	7
BLOWER SPEED CONNECTIONS	7
ACCESSORIES	8
FILTER RACK DIMENSIONS	8
TYPICAL APPLICATIONS	8
LIMITATIONS	8
COMBUSTIBLE FLOOR BASE ACCESSORY	9
TYPICAL THERMOSTAT CONNECTION	9
AIRFLOW DATA - CFM	10

NOMENCLATURE

PRODUCT TYPE	M	M = Modular Blower
POSITION MOTOR TYPE	E	P = Multi PSC E = Multi Std ECM V = Multi VS ECM
OPTIONS	-	C = Communications Ready - (No Designator) = Standard (No Options)
NOMINAL AIRFLOW	12	08 = 800 CFM 12 = 1,200 CFM 14 = 1,400 CFM 16 = 1,600 CFM 20 = 2,000 CFM
CABINET WIDTH	B	A = 14.5" B = 17.5" C = 21.0" D = 24.5"
OPTIONS	N	N = No options
VOLTAGE (Voltage-Phase-Hertz)	4	2 = 208/230-1-60 4 = 460-3-60
GENERATION (MAJOR REVISION)	1	1 = 1st Gen 2 = 2nd Gen etc.
STYLE LETTER (MINOR REVISION) NOT USED FOR ORDERING	A	A = Style A B = Style B etc.

DIMENSIONS AND DUCT CONNECTION DIMENSIONS

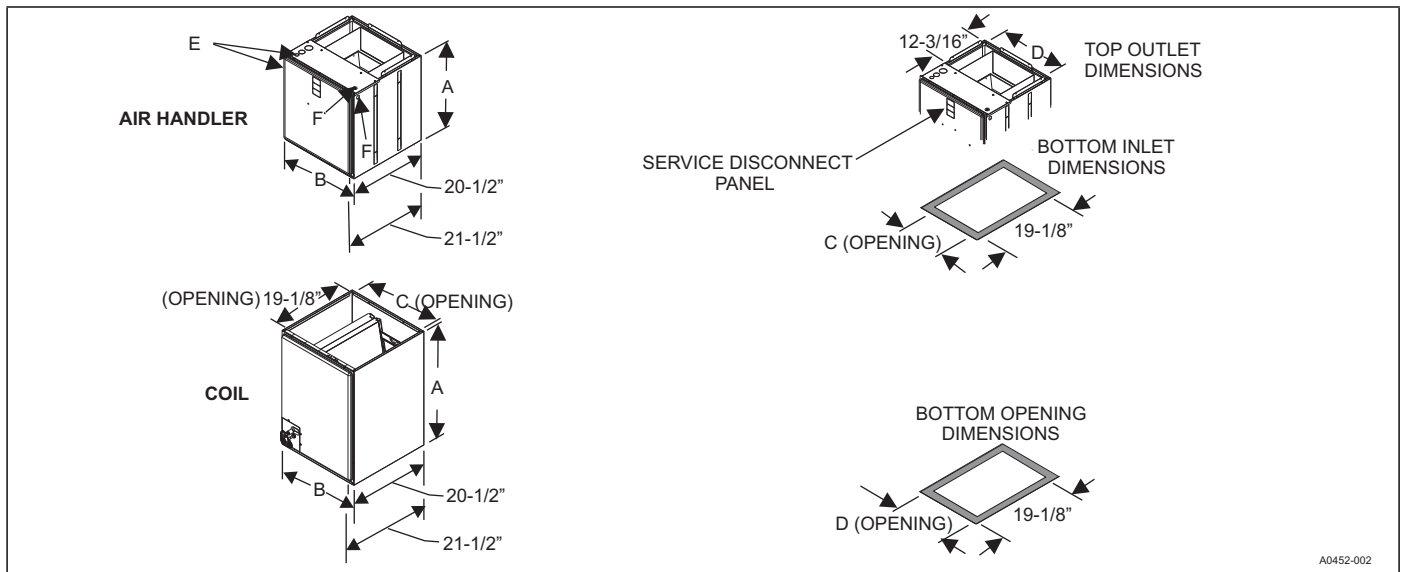

DIMENSIONS - ME MODULAR AIR HANDLERS AND CM MULTI-POSITION FULL CASED COILS

Models	Dimensions ¹					Wiring Knockout Dimensions	
	Height	Width	Opening Widths		E	F	
	A	B	C	D	Power	Control	
ME12BN41	21-1/2	17-1/2	16-1/2	16-1/2	7/8 (1/2), 1-3/8 (1), 1-23/32 (1-1/4)	7/8 (1/2)	
ME12CN41	22-1/2	21	20	20			
ME14DN41	22-1/2	24-1/2	23-1/2	23-1/2			
ME16CN41	22-1/2	21	20	20			
ME20DN41	22-1/2	24-1/2	23-1/2	23-1/2			
Models ²	Dimensions ¹					Refrigerant Connections ^{3,4,5}	
	Height	Width	Opening Widths		Line Size		
	A	B	C	D	Liquid	Vapor	
CM18A*	19-1/2	14-1/2	13-1/2	13-1/2	3/8	3/4	
CM18B	19	17-1/2	16-1/2	16-1/2			
CM24A*	19-1/2	14-1/2	13-1/2	13-1/2			
CM24B*	19	17-1/2	16-1/2	16-1/2			
CM24C	21	21	20	20			
CM30A*	25-1/2	14-1/2	13-1/2	13-1/2			
CM30B*	23	17-1/2	16-1/2	16-1/2			
CM30C	23	21	20	20			
CM30D	25	24-1/2	23-1/2	23-1/2			
CM36A	25-1/2	14-1/2	13-1/2	13-1/2			
CM36B*	25-5/8	17-1/2	16-1/2	16-1/2			
CM36C*	25	21	20	20			
CM36D	25	24-1/2	23-1/2	23-1/2			
CM42C*	27	21	20	20			
CM42D	27	24-1/2	23-1/2	23-1/2			
CM48C*	33	21	20	20	7/8		
CM48D*	32-3/4	24-1/2	23-1/2	23-1/2			
CM50C	37-1/4	21	20	20			
CM60C*	33	21	20	20			
CM60D*	32-3/4	24-1/2	23-1/2	23-1/2			
CM64D	32-3/4	24-1/2	23-1/2	23-1/2			

1. All dimensions are in inches.
 2. An asterisk (*) denotes coils available with factory installed TXV.
 3. Refrigerant line sizes may require larger lines for extended line lengths. Refer to Application Data part number 247077.
 4. The adapter fitting must be field installed for other line set sizes.
 5. Refer to the outdoor unit technical guide for proper line set size.

COOLING CAPACITY¹

Models	Rated CFM ²	Entering Air Dry/Wet Bulb (°F)	MBH@ Evap. Temp. and Corresponding R-410A Pressure (°F/PSIG)			
			35/107.9	40/118.9	45/130.7	50/143.3
CM18B	600	85/72	45.7	41.6	36.8	30.5
		80/67	38.5	33.9	28.5	22.3
		75/62	31.5	26.5	20.5	15.9
		70/57	24.4	19.5	15.2	11.5
CM24B	800	85/72	52.2	47.5	41.8	35.0
		80/67	43.6	38.3	31.9	24.5
		75/62	35.2	29.5	22.7	16.2
		70/57	27.1	20.7	15.5	11.4
CM24C	800	85/72	52.2	47.5	41.8	35.0
		80/67	43.6	38.3	31.9	24.5
		75/62	35.2	29.5	22.7	16.2
		70/57	27.1	20.7	15.5	11.4
CM30B	1000	85/72	75.3	67.8	56.8	47.1
		80/67	62.6	54.6	44.2	34.5
		75/62	50.2	41.3	32.0	22.9
		70/57	37.8	30.1	21.5	16.2
CM30C	1000	85/72	75.3	67.8	56.8	47.1
		80/67	62.6	54.6	44.2	34.5
		75/62	50.2	41.3	32.0	22.9
		70/57	37.8	30.1	21.5	16.2
CM30D	1000	85/72	75.3	67.8	56.8	47.1
		80/67	62.6	54.6	44.2	34.5
		75/62	50.2	41.3	32.0	22.9
		70/57	37.8	30.1	21.5	16.2
CM36B	1000	85/72	82.1	73.7	64.1	54.4
		80/67	68.6	60.1	50.5	39.5
		75/62	56.3	47.0	37.3	29.2
		70/57	43.5	36.0	28.3	21.6
CM36B	1200	85/72	91.6	82.4	71.3	59.4
		80/67	76.5	65.4	54.6	42.8
		75/62	61.3	51.2	40.0	30.5
		70/57	47.5	38.1	28.7	22.3
CM42C	1200	85/72	98.0	88.6	77.4	66.4
		80/67	82.6	72.6	61.7	50.6
		75/62	68.5	57.6	47.5	36.6
		70/57	53.9	44.8	35.0	28.4
CM36C	1200	85/72	91.6	82.4	71.3	59.4
		80/67	76.5	65.4	54.6	42.8
		75/62	61.3	51.2	40.0	30.5
		70/57	47.5	38.1	28.7	22.3
CM36D	1200	85/72	91.6	82.4	71.3	59.4
		80/67	76.5	65.4	54.6	42.8
		75/62	61.3	51.2	40.0	30.5
		70/57	47.5	38.1	28.7	22.3
CM42C	1400	85/72	100.6	89.8	78.2	64.7
		80/67	83.5	73.7	59.8	48.0
		75/62	67.8	55.8	44.7	32.5
		70/57	52.3	41.5	30.7	23.7
CM42D	1400	85/72	100.6	89.8	78.2	64.7
		80/67	83.5	73.7	59.8	48.0
		75/62	67.8	55.8	44.7	32.5
		70/57	52.3	41.5	30.7	23.7

Continued on next page

COOLING CAPACITY¹ (Continued)

Models	Rated CFM ²	Entering Air Dry/Wet Bulb (°F)	MBH@ Evap. Temp. and Corresponding R-410A Pressure (°F/PSIG)			
			35/107.9	40/118.9	45/130.7	50/143.3
CM48C	1400	85/72	108.0	98.4	88.1	73.8
		80/67	93.3	82.1	69.7	57.0
		75/62	75.9	64.4	53.1	41.9
		70/57	60.7	49.9	39.4	32.4
CM48C	1600	85/72	115.2	105.0	93.9	79.0
		80/67	88.3	78.2	65.5	52.6
		75/62	72.7	60.8	50.1	37.6
		70/57	57.7	46.9	36.6	29.7
CM48D	1600	85/72	115.2	105.0	93.9	79.0
		80/67	88.3	78.2	65.5	52.6
		75/62	72.7	60.8	50.1	37.6
		70/57	57.7	46.9	36.6	29.7
CM60C	1800	85/72	115.1	103.0	91.7	78.6
		80/67	96.8	85.9	73.7	60.5
		75/62	80.7	69.4	57.5	43.5
		70/57	58.7	48.9	37.7	32.7
CM50C	1800	85/72	122.9	111.8	98.0	82.6
		80/67	102.2	89.8	75.7	59.9
		75/62	82.5	69.7	54.9	38.7
		70/57	64.3	50.8	38.2	29.4
CM60D	1800	85/72	115.1	103.0	91.7	78.6
		80/67	96.8	85.9	73.7	60.5
		75/62	80.7	69.4	57.5	43.5
		70/57	58.7	48.9	37.7	32.7
CM64D	1800	85/72	133.6	118.5	103.2	86.6
		80/67	111.4	96.2	80.3	62.8
		75/62	90.7	75.1	60.0	43.5
		70/57	70.6	56.9	42.5	32.8

1. Refer to the condensing unit or heat pump technical guide for total cooling capacity and sensible capacity.
2. Airflow is calculated for each system tonnage.

PHYSICAL AND ELECTRICAL DATA - COOLING ONLY

Models		ME12B	ME12C	ME14D	ME16C	ME20D
Blower - Diameter x Width		10 x 8	11 x 10	11 x 10	11 x 10	11 x 10
Motor	HP	1/2 HP	1/2 HP	1/2 HP	1 HP	1 HP
	Nominal RPM	1400	1400	1400	1400	1400
Voltage		460	460	460	460	460
Full Load Amps @460 V		2.0	2.0	2.0	3.2	3.2
Filter ¹	Type	DISPOSABLE OR WASHABLE				
	Size	16 x 20 x 1	20 x 20 x 1	22 x 20 x 1	20 x 20 x 1	22 x 20 x 1
	Bottom Rack Kit	1BR01117	1BR01121	1BR01124	1BR01121	1BR01124
	Permanent Type Kit	1PF0601	1PF0602	1PF0603	1PF0602	1PF0603
Shipping/Operating Weight (lb)		52/51	68/67	75/74	68/67	75/74

1. Field supplied

APPLICATION FACTORS - RATED CFM VS. ACTUAL CFM

% Of Rated Airflow (CFM)	80%	90%	100%	110%	120%
Capacity Factor	0.96	0.98	1.00	1.02	1.03

ELECTRICAL DATA - COOLING ONLY

Models	Motor FLA ¹	Minimum Circuit Ampacity	MOP ²
ME12B/ME12C/ME14D	2.0	2.4	15
ME16C/ME20D	3.2	3.9	

1. FLA = Full Load Amps

2. MOP = Maximum Overcurrent Protection device. Must be HACR type circuit breaker or time delay fuse. To determine correct wire sizing, refer to the latest edition of the National Electrical Code or the Canadian Electrical Code as relevant and local codes.

ELECTRICAL HEAT - MINIMUM FAN SPEED

Heat Kit Models ¹	Nom. kW @240 V	Air Handler Models				
		ME12B	ME12C	ME14D	ME16C	ME20D
6HK06501046	9.6 kW	Medium Low (2)	Medium High (4)	Medium (3)	Medium Low (2)	Medium Low (2)
6HK06501546	14.4 kW	High (5)	Medium High (4)	Medium (3)	Medium Low (2)	Medium Low (2)
6HK06501846	17.3 kW	High (5)	Medium High (4)	Medium High (4)	Medium (3)	Medium (3)
6HK06502046	19.2 kW	High (5)	High (5)	-	Medium High (4)	Medium (3)
6HK06502546	24 kW	-	-	-	-	Medium (3)

1. Kits have no service disconnect. Terminal blocks only

ELECTRIC HEAT PERFORMANCE DATA: 460-3-60

Heater Models ¹		Total Heat	
		kW	MBH
		480 V	48 V
3PH	6HK06501046	9.6	32.8
	6HK06501546	14.4	49.1
	6HK06501846	17.3	59.0
	6HK06502046	19.2	65.5
	6HK06502546	24	81.9

1. Kits have no service disconnect. Terminal blocks only

ELECTRICAL DATA FOR SINGLE SOURCE POWER SUPPLY: 460-3-60

Air Handler Models	Heater Models ¹	Heater Amps @480 V	Field Wiring	
			Min. Circuit Ampacity	MOP ²
			480 V	480 V
ME12B	6HK06501046	11.6	17.0	20
	6HK06501546	17.3	24.2	25
	6HK06501846	20.8	28.5	30
	6HK06502046	23.1	31.4	35
ME12C	6HK06501046	11.6	17.0	20
	6HK06501546	17.3	24.2	25
	6HK06501846	20.8	28.5	30
	6HK06502046	23.1	31.4	35
ME14D	6HK06501046	11.6	17.0	20
	6HK06501546	17.3	24.2	25
	6HK06501846	20.8	28.5	30
ME16C	6HK06501046	11.6	18.5	20
	6HK06501546	17.3	25.7	30
	6HK06501846	20.8	30.0	30
	6HK06502046	23.1	32.9	35
ME20D	6HK06501046	11.6	18.5	20
	6HK06501546	17.3	25.7	30
	6HK06501846	20.8	30.0	30
	6HK06502046	23.1	32.9	35
	6HK06502546	28.9	40.1	45

1. Kits have no service disconnect. Terminal blocks only
2. MOP = Maximum Overcurrent Protection device. Must be HACR type circuit breaker or time delay fuse. To determine correct wire sizing, refer to the latest edition of the National Electrical Code or the Canadian Electrical Code as relevant and local codes.

POWER WIRING - LINE CONNECTIONS

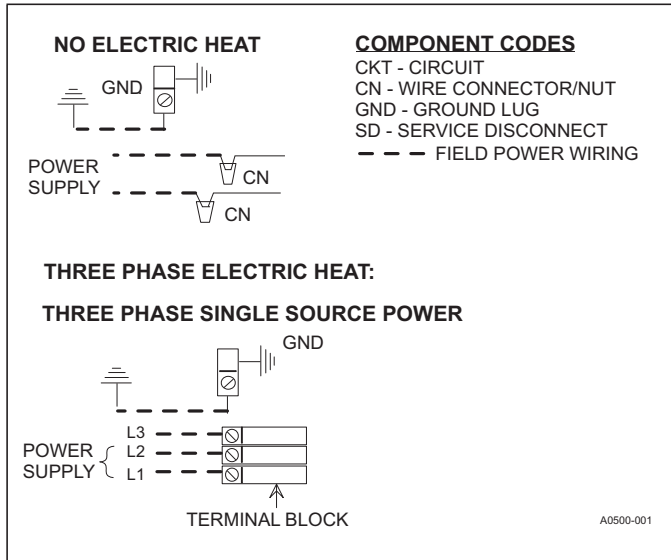

BLOWER SPEED CONNECTIONS

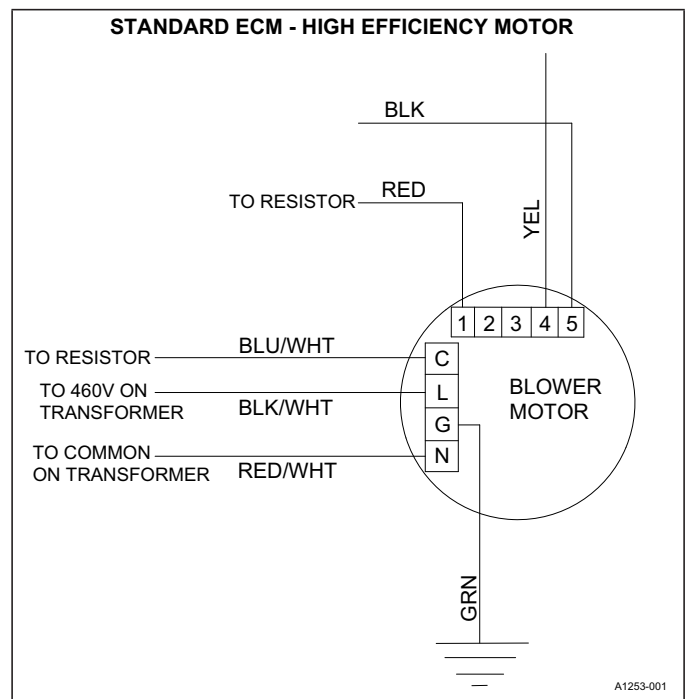

ACCESSORIES

Refer to the Price Manual for specific model numbers where not shown.

TXV Kits - Air handlers are shipped with “Flex-coils” without a factory installed metering device. For added flexibility, an R-22 or R-410A TXV or piston can be field installed to meet your refrigerant choice. All TXV kits are chatteff style and require no brazing to install. Some models are available with a factory installed TXV.

Electric Heaters - The 6HK models shown under electrical data include temperature dual limit switches for safe, efficient operation. Service disconnect is field provided.

Combustible Floor Base Accessory - If an electric heat accessory that is rated for greater than zero clearance to combustible surfaces is installed in these air handlers in the downflow operating positions on a combustible floor, one of the following combustible floor base accessory models is required: S1-1FB1917, S1-1FB1921, or S1-1FB1924.

Breaker Moisture Seal Accessory - A clear service disconnect moisture barrier seals the disconnects from humidity and dust. The flexibility of the clear cover allows service disconnects to be turned ON or OFF without removing the cover. The cover firmly attaches to the access panel around the service disconnects with the use of double backed adhesive tape. To ensure that moisture or dust does not contaminate service disconnects, an S1-02435672000 Cover Breaker Moisture Seal can be ordered.

Thermostat - Compatible thermostat controls are available through accessory sourcing. For optimum performance, these outdoor units are fully compatible with our Coleman touch screen thermostat with proprietary (patent-pending) hexagon interface. For more information, refer to the thermostat section of the Product Equipment Catalog.

FILTER RACK DIMENSIONS

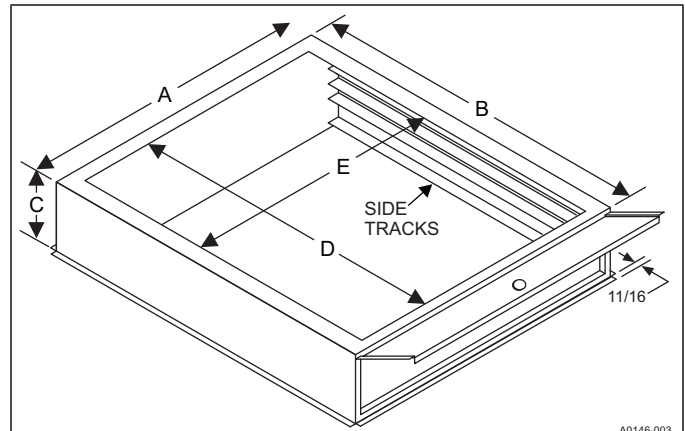

Galvanized Models	A	B	C	D	E	Filter Size
1BR01117	17.50	21.56	4.00	18.63	14.25	16 x 20 x 1 or 2
1BR01121	21.00	21.56	4.00	18.63	17.75	20 x 20 x 1 or 2
1BR01124	24.50	21.56	4.00	18.63	21.25	20 x 24 x 1 or 2

Note: Filters are not supplied with kit.

TYPICAL APPLICATIONS

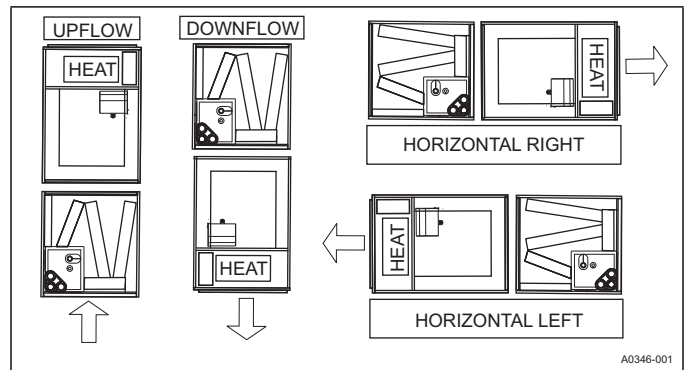

LIMITATIONS

These units must be wired and installed in accordance with all national and local safety codes.

Voltage limits are as follows:

Air Handler Voltage	Normal Operating Voltage Range ¹
460-3-60	432-504

1. Rated in accordance with ARI Standard 110, utilization range “A”

Airflow must be within the minimum and maximum limits approved for electric heat, evaporator coils, and outdoor units.

COMBUSTIBLE FLOOR BASE ACCESSORY

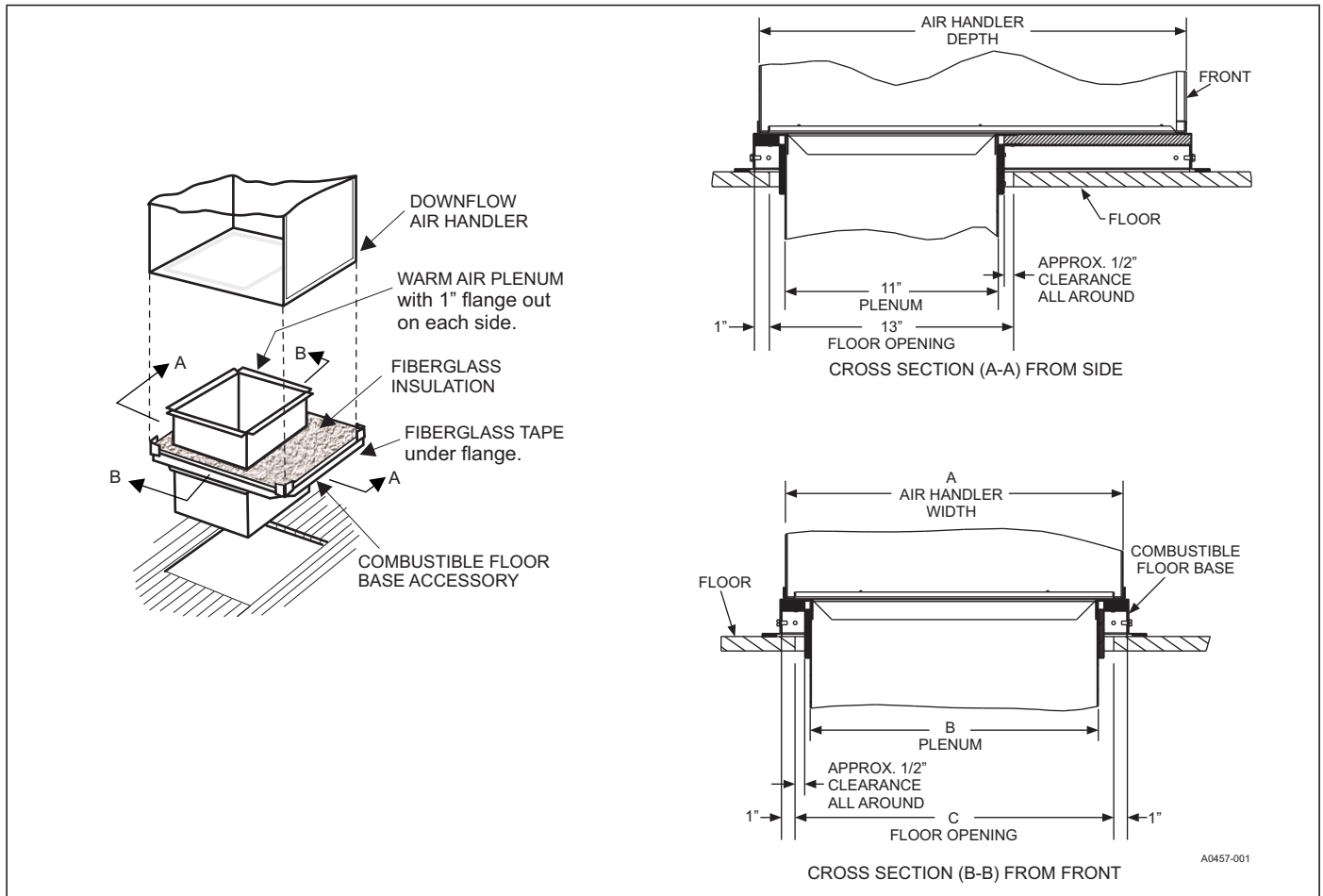

Floor Base Models	Used with	Dimensions		
		A	B	C
1FB1917	ME12B	17.5	14.0	16.0
1FB1921	ME12C, ME16C	21.0	17.5	19.5
1FB1924	ME14D, ME20D	24.5	21.0	23.0

TYPICAL THERMOSTAT CONNECTION

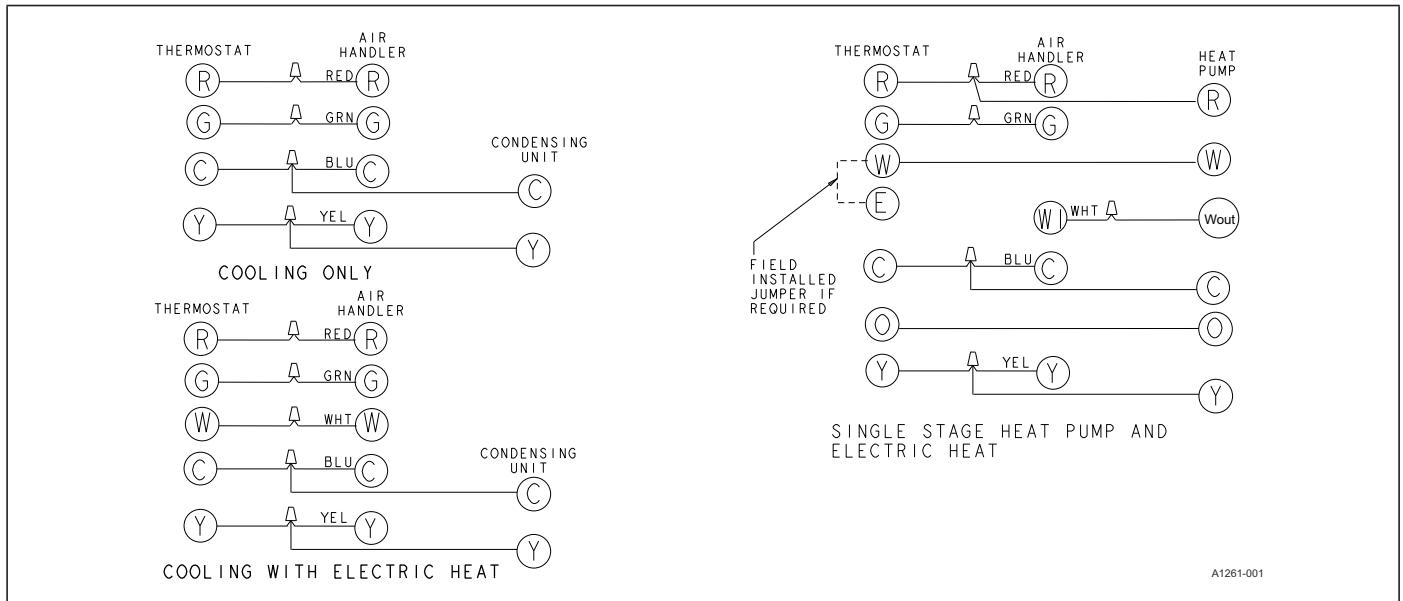

AIRFLOW DATA - CFM¹

Models	CM Models	Blower Motor Speed	External Static Pressure (in. wc.)						
			0.10	0.20	0.30	0.40	0.50	0.60	0.70
ME12B	CM18B	High (5)	1355	1334	1302	1270	1231	1201	1170
		Medium High (4)	1273	1244	1213	1177	1142	1109	1073
		Medium (3)	1074	1041	1009	974	936	894	809
		Medium Low (2)	862	826	798	766	688	607	587
		Low (1)	659	616	560	512	457	387	275
	CM24B	High (5)	1359	1331	1301	1269	1234	1202	1171
		Medium High (4)	1272	1245	1209	1174	1143	1106	1073
		Medium (3)	1072	1040	1007	973	937	874	778
		Medium Low (2)	857	821	794	756	676	613	567
	CM30B	Low (1)	654	606	557	504	443	379	271
		High (5)	1354	1325	1294	1263	1230	1198	1168
		Medium High (4)	1268	1235	1203	1171	1139	1107	1075
		Medium (3)	1069	1038	1003	974	935	876	781
	CM36B	Medium Low (2)	859	818	794	756	681	620	563
		Low (1)	654	608	552	503	434	364	289
		High (5)	1348	1317	1285	1254	1222	1189	1157
Medium High (4)		1258	1225	1192	1160	1126	1093	1063	
ME12C	CM50C	Medium (3)	1062	1029	993	964	929	879	778
		Medium Low (2)	860	822	791	761	682	616	568
		Low (1)	642	599	554	502	431	367	294
		High (5)	1360	1334	1291	1253	1207	1172	1076
		Medium High (4)	1274	1242	1202	1157	1109	1040	1000
ME14D	CM30D	Medium (3)	1060	1022	968	923	854	766	694
		Medium Low (2)	910	863	806	722	660	567	524
		Low (1)	655	585	511	436	385	323	267
		High (5)	1583	1546	1516	1477	1435	1401	1364
		Medium High (4)	1499	1456	1426	1393	1349	1306	1267
	CM36D	Medium (3)	1295	1247	1217	1181	1135	1080	1005
		Medium Low (2)	1099	1075	1026	983	909	840	786
		Low (1)	906	875	834	754	675	589	521
		High (5)	1604	1563	1524	1479	1450	1410	1374
		Medium High (4)	1508	1464	1428	1384	1350	1308	1271
	CM42D	Medium (3)	1300	1250	1209	1175	1132	1075	1006
		Medium Low (2)	1102	1058	1028	986	909	838	784
		Low (1)	912	884	831	763	694	568	530
		High (5)	1544	1520	1482	1440	1411	1367	1321
		Medium High (4)	1455	1426	1393	1349	1305	1272	1207
ME14D	CM42D	Medium (3)	1263	1238	1197	1157	1100	1033	980
		Medium Low (2)	1074	1037	993	946	877	810	729
		Low (1)	888	853	787	736	644	571	508

Continued on next page

AIRFLOW DATA - CFM¹ (Continued)

Models	CM Models	Blower Motor Speed	External Static Pressure (in. wc.)						
			0.10	0.20	0.30	0.40	0.50	0.60	0.70
ME16C	CM36C	High (5)	1776	1735	1700	1657	1617	1577	1529
		Medium High (4)	1701	1663	1621	1583	1538	1497	1453
		Medium (3)	1522	1475	1442	1394	1349	1301	1245
		Medium Low (2)	1297	1250	1203	1151	1101	1050	957
		Low (1)	1112	1052	1002	951	854	816	756
	CM42C	High (5)	1754	1719	1678	1644	1599	1562	1513
		Medium High (4)	1676	1637	1599	1562	1517	1476	1423
		Medium (3)	1495	1454	1411	1371	1328	1280	1233
		Medium Low (2)	1286	1235	1198	1143	1097	1036	992
		Low (1)	1119	1055	1006	948	900	804	752
	CM48C	High (5)	1769	1727	1689	1650	1608	1568	1525
		Medium High (4)	1692	1648	1605	1568	1525	1485	1440
		Medium (3)	1554	1505	1461	1420	1373	1326	1273
		Medium Low (2)	1308	1256	1213	1164	1088	1007	941
		Low (1)	1116	1057	1007	955	839	792	741
	CM60C	High (5)	1794	1757	1720	1686	1639	1589	1545
		Medium High (4)	1700	1664	1624	1582	1543	1496	1443
		Medium (3)	1530	1484	1444	1402	1356	1314	1257
		Medium Low (2)	1305	1257	1217	1162	1115	1060	993
		Low (1)	1124	1060	1008	954	889	827	755
ME20D	CM36D	High (5)	2061	2021	1979	1938	1904	1865	1829
		Medium High (4)	1998	1949	1914	1879	1835	1797	1756
		Medium (3)	1769	1711	1677	1643	1603	1570	1530
		Medium Low (2)	1557	1508	1469	1439	1398	1355	1323
		Low (1)	1340	1291	1252	1216	1170	1132	1058
	CM42D	High (5)	2032	1996	1959	1913	1890	1849	1820
		Medium High (4)	1974	1938	1892	1855	1824	1785	1754
		Medium (3)	1752	1706	1680	1633	1591	1546	1511
		Medium Low (2)	1545	1505	1468	1432	1393	1351	1307
		Low (1)	1340	1296	1260	1219	1169	1118	1055
	CM48D	High (5)	2062	2024	1993	1952	1910	1868	1836
		Medium High (4)	2006	1958	1932	1890	1850	1815	1770
		Medium (3)	1785	1741	1698	1646	1610	1582	1538
		Medium Low (2)	1564	1521	1477	1443	1398	1362	1323
		Low (1)	1350	1305	1257	1226	1181	1112	1029
	CM60D	High (5)	1998	1959	1923	1888	1862	1826	1786
		Medium High (4)	1933	1887	1855	1811	1791	1757	1719
		Medium (3)	1703	1670	1633	1592	1567	1531	1485
		Medium Low (2)	1522	1474	1447	1403	1370	1328	1281
		Low (1)	1306	1260	1223	1190	1131	1078	1012
CM64D	High (5)	1940	1897	1868	1832	1806	1770	1728	
	Medium High (4)	1883	1860	1829	1789	1761	1728	1688	
	Medium (3)	1686	1648	1619	1584	1537	1508	1466	
	Medium Low (2)	1490	1446	1415	1385	1346	1298	1236	
	Low (1)	1279	1248	1206	1167	1113	1062	972	

1. Air handler units have been tested to UL 1995/CSA 22.2 No. 236 standards up to 0.50" wc. external static pressure.

Dry coil conditions only, tested without filters.

For optimal performance, external static pressures of 0.2" to 0.5" are recommended. Heating applications tested at 0.50" w.c. esp.

Airflow data shown is from testing performed at 460 V. AE units use a standard ECM constant torque motor, and there is minimal variation of airflow at other distribution voltage values.

NOTES